



HOSHIZAKI

Instruction Manual

Modular Crescent Cuber

Models

KM-322_522_622MAK

KM-330_530_730MAK

KM-930MAK2

KM-1130MAK2



hoshizakiamerica.com

Issued: 11-12-2025
Revised: 4-14-2026

⚠ WARNING

Only qualified service technicians should install and service the appliance. To obtain the name and phone number of your local Hoshizaki Certified Service Representative, visit www.hoshizakiamerica.com. No installation, operation, maintenance, or service should be undertaken until the technician has thoroughly read this Instruction Manual. No service should be undertaken until the technician has thoroughly read the service manual available at www.hoshizakiamerica.com. Likewise, the owner/manager should not proceed to operate the appliance until the installer has instructed them on its proper operation. Failure to install, operate, and maintain the appliance in accordance with this manual will adversely affect safety, performance, component life, and warranty coverage and may result in costly water damage. Proper installation is the responsibility of the installer. Product failure or property damage due to improper installation is not covered under warranty.

Hoshizaki provides this manual primarily to assist qualified service technicians in the installation, operation, maintenance, and service of the appliance.

Should the reader have any questions or concerns which have not been satisfactorily addressed, please call, send an e-mail message, or write to the Hoshizaki Technical Support Department for assistance.

Phone: 1-800-233-1940; (770) 487-2331

E-mail: tech-support@hoshizaki.com

HOSHIZAKI AMERICA, INC.

618 Highway 74 South
Peachtree City, GA 30269
Attn: Hoshizaki Technical Support Department

NOTE: To expedite assistance, all correspondence/communication **MUST** include the following information:

- Model Number _____
- Serial Number _____
- Complete and detailed explanation of the problem.

IMPORTANT

This manual should be read carefully before the appliance is installed and operated. Read the warnings and guidelines contained in this manual carefully as they provide essential information for the continued safe use and maintenance of the appliance. Retain this manual for any further reference that may be necessary.

CONTENTS

Important Safety Information	4
I. Specifications.....	9
A. Electrical and Refrigerant Data	9
B. Dimensions/Connections	11
II. Installation Instructions	14
A. Location	15
B. Checks Before Installation.....	16
C. How to Remove Panels	17
D. Dispenser Unit/Ice Storage Bin and Icemaker Setup	18
E. Electrical Connection	19
F. Water Supply and Drain Connections	20
G. Final Checklist	22
1. Pre-Startup	22
2. Post-Startup.....	22
III. Operating Instructions.....	23
A. Important Notes About Usage.....	23
B. Startup	24
1. Bin Control Setting	24
2. Appliance Startup and Bin Control Check	30
C. Alarm Safeties	34
IV. Maintenance	35
A. User Maintenance Schedule	35
B. Service Maintenance Schedule.....	36
C. Cleaning and Sanitizing Instructions.....	37
V. Preparing the Appliance for Periods of Non-Use	40
VI. Decommissioning and Disposal	43

Important Safety Information

Throughout this manual, notices appear to bring your attention to situations which could result in death, serious injury, damage to the appliance, or damage to property.

	R-290 Class A3 Flammable Refrigerant Used*
⚠ DANGER	Indicates a hazardous situation that, if not avoided, will result in death or serious injury.
⚠ WARNING	Indicates a hazardous situation that, if not avoided, could result in death or serious injury.
NOTICE	Indicates a situation that, if not avoided, could result in damage to the appliance or property.
IMPORTANT	Indicates important information about the use and care of the appliance.

⚠ DANGER	
<p><u>Risk of Fire or Explosion</u> <u>Flammable Refrigerant Used*</u></p> <ul style="list-style-type: none"> • Only qualified service technicians should install and service the appliance. • No installation, operation, or maintenance should be undertaken until the technician has thoroughly read this Instruction Manual. All safety precautions must be followed. • No service should be undertaken until the technician has thoroughly read the Service Manual available at www.hoshizakiamerica.com. All safety precautions must be followed. • This appliance to be installed in accordance with the Safety Standard for Refrigeration Systems ANSI/ASHRAE 15. • Follow handling instructions carefully in compliance with national regulations. • Do not use mechanical devices or other means to accelerate the defrosting process or to clean, other than those recommended by the manufacturer. • Do not puncture refrigerant tubing. Risk of fire or explosion due to puncture of refrigerant tubing; follow handling instructions carefully.* 	<ul style="list-style-type: none"> • Servicing shall be done by trained service personnel with certified competence in handling flammable refrigerants to minimize the risk of possible ignition due to incorrect parts or improper service.* • Component parts shall be replaced with like components, so as to minimize the risk of possible ignition due to incorrect parts.* • Dispose of properly in accordance with federal or local regulations. • Do not pierce or burn. • Be aware that refrigerants may not contain an odor. • Do not damage the refrigeration circuit. • See nameplate for R-290 refrigerant charge:* <ul style="list-style-type: none"> • If greater than 114 g (4 oz.), do not install in public corridor or lobby. • If greater than 152 g (5.3 oz.), do not install within 6 m (20 ft) of open flame. • The appliance shall be stored in a room without continuously operating ignition sources (for example: open flames, an operating gas appliance, or an operating electric heater).*

*This statement applies to models utilizing R-290 refrigerant.

⚠ DANGER continued

- Do not place any potential ignition sources in or near the appliance.
- Keep clear of obstruction all ventilation openings in the appliance enclosure or in the structure for building-in.
- No potential sources of ignition are to be used in the searching for or detection of refrigerant leaks.
- Do not use electrical appliances inside the appliance unless they are of the type recommended by the manufacturer.
- Do not store explosive substances such as aerosol cans with a flammable propellant in this appliance.
- Check that cabling will not be subject to wear, corrosion, excessive pressure, vibration, sharp edges, or any other adverse environmental effects. The check shall also take into account the effects of aging or continual vibration from sources such as compressors or fans.
- Ensure that the area is in the open or that it is adequately ventilated before breaking into the system or conducting any hot work. A degree of ventilation shall continue during the period that the work is carried out. The ventilation should safely disperse any released refrigerant and preferably expel it externally into the atmosphere.
- This appliance shall be used on a dispenser unit/ice storage bin without electrical components or one designed to be used with flammable refrigerants, and of size or type as indicated in this manual.*

*This statement applies to models utilizing R-290 refrigerant.

**Risque D'Incendie ou D'Explosion
Fluide Frigorigène Inflammable Utilisé**

- Seuls des techniciens de service qualifiés doivent installer et entretenir l'appareil.
- Aucune installation, opération ou maintenance ne doit être entreprise avant que le technicien n'ait lu attentivement ce manuel d'instructions. Toutes les précautions de sécurité doivent être suivies.
- Aucune opération d'entretien ne doit être entreprise avant que le technicien n'ait lu attentivement le manuel d'entretien disponible sur le site www.hoshizakiamerica.com. Toutes les précautions de sécurité doivent être suivies.
- Cet appareil doit être installé conformément à la norme de sécurité pour les systèmes de réfrigération ANSI/ASHRAE 15.
- Suivez attentivement les instructions de manutention conformément aux règlements nationaux.
- Ne pas utiliser de dispositifs mécaniques ou d'autres moyens pour accélérer le processus de dégivrage ou pour nettoyer, autres que ceux recommandés par le fabricant.
- Ne pas perforer la conduite de fluide frigorigène. Risque d'incendie ou d'explosion en cas de perforation d'une canalisation de fluide frigorigène; suivez attentivement les instructions de manutention.*
- L'entretien doit être effectué par du personnel formé et certifié pour la manipulation de réfrigérants inflammables afin de réduire au minimum le risque d'inflammation dû à des pièces incorrectes ou à un entretien inadéquat.*

*Cette déclaration s'applique aux modèles utilisant le réfrigérant R-290.

⚠ DANGER Continué

- Les pièces doivent être remplacées par des pièces similaires, de manière à réduire au minimum le risque d'inflammation dû à des pièces incorrectes.*
 - Mettre au rebut conformément aux règlements fédéraux ou locaux.
 - Ne pas percer ou brûler.
 - Attention, les fluides frigorigènes peuvent ne pas dégager d'odeur.
 - Ne pas endommager les composants du circuit de réfrigération.
 - Voir plaque signalétique pour la charge de réfrigérant R-290:*
 - Si elle est supérieure à 114 g (4 oz.), ne pas l'installer dans un couloir public ou un hall d'entrée.
 - Si elle est supérieure à 152 g (5.3 oz.), ne pas l'installer à moins de 6 m (20 pi) d'une flamme nue.
 - L'appareil doit être entreposé dans un local ne contenant pas de sources d'inflammation permanentes (flammes nues, appareil à gaz ou dispositif de chauffage électrique en fonctionnement, par exemple).*
 - Ne placer aucune source d'inflammation potentielle à l'intérieur ou à proximité de l'appareil.
 - Ne pas obstruer les ouvertures de ventilation dans l'enceinte de l'appareil ou dans la structure d'encastrement.
 - Aucune source potentielle d'inflammation ne doit être utilisée pour rechercher ou détecter des fuites de réfrigérant.
 - Ne pas utiliser d'appareils électriques à l'intérieur de l'appareil, sauf s'ils sont du type recommandé par le fabricant.
 - Ne pas entreposer dans cet appareil des substances explosives telles que des bombes aérosols contenant un gaz propulseur inflammable.
- Vérifier que le câblage ne sera pas soumis à l'usure, à la corrosion, à une pression excessive, à des vibrations, à des arêtes vives ou à tout autre effet environnemental négatif. Le contrôle doit également prendre en compte les effets du vieillissement ou des vibrations continues provenant de sources telles que les compresseurs ou les ventilateurs.
 - S'assurer que la zone est à l'air libre ou qu'elle est correctement ventilée avant de pénétrer dans le système ou d'effectuer un travail à chaud. Une certaine ventilation doit être maintenue pendant la durée des travaux. La ventilation doit permettre de disperser en toute sécurité tout réfrigérant libéré et, de préférence, de l'expulser dans l'atmosphère.
 - Cet appareil doit être utilisé sur un distributeur/bac de stockage à glace sans composants électriques ou conçu pour être utilisé avec des réfrigérants inflammables, et d'une taille ou d'un type conforme aux indications de ce manuel.*

*Cette déclaration s'applique aux modèles utilisant le réfrigérant R-290.

WARNING

The appliance should be destined only to the use for which it has been expressly conceived. Any other use should be considered improper and therefore dangerous. The manufacturer cannot be held responsible for injury or damage resulting from improper, incorrect, and unreasonable use. Failure to install, operate, and maintain the appliance in accordance with this manual will adversely affect safety, performance, component life, and warranty coverage and may result in costly water damage. **To reduce the risk of death, electric shock, serious injury, or fire, follow basic precautions including the following:**

- This appliance is intended for use at altitudes up to 7,000 m (22,965 ft).
- Wear appropriate personal protective equipment (PPE) when servicing the appliance.
- The appliance must be installed in accordance with applicable national, state, and local codes and regulations.
- Electrical connection must be hard-wired and must meet national, state, and local electrical code requirements. Failure to meet these code requirements could result in death, electric shock, serious injury, fire, or damage.
- The appliance requires an independent power supply of proper capacity. See the nameplate for electrical specifications. Failure to use an independent power supply of proper capacity can result in a tripped breaker, blown fuse, damage to existing wiring, or component failure. This could lead to heat generation or fire.
- **THE APPLIANCE MUST BE GROUNDED.** Failure to properly ground the icemaker could result in death or serious injury.
- To reduce the risk of electric shock, do not touch the control switch or mode switch with damp hands.
- Move the control switch to the "OFF" position and turn off the power supply before servicing. Lockout/Tagout to prevent the power supply from being turned back on inadvertently.
- Risk of electric shock. Power switch in "OFF" position does not de-energize all loads. Use extreme caution and exercise safe electrical practices.
- Do not make any alterations to the appliance. Alterations could result in electric shock, injury, fire, or damage to the appliance.
- Appliance is heavy. Use care when lifting or positioning. Work in pairs when needed to prevent injury or damage.
- The appliance is not intended for use by persons (including children) with reduced physical, sensory, or mental capabilities, or lack of experience and knowledge, unless they have been given supervision or instruction concerning use of the appliance by a person responsible for their safety.
- Do not splash, pour, or spray water directly onto or into the appliance. This might cause short circuit, electric shock, corrosion, or failure.
- Children should be supervised to ensure that they do not play with the appliance.
- Do not climb, stand, or hang on the appliance or allow children or animals to do so. Serious injury could occur or the appliance could be damaged.
- Do not use combustible spray or place volatile or flammable substances in or near the appliance. They might catch fire.
- Keep the area around the appliance clean. Dirt, dust, or insects in the appliance could cause harm to individuals or damage to the appliance.

NOTICE

- Follow the water supply, drain connection, and maintenance instructions carefully to reduce the risk of costly water damage.
- In areas where water damage is a concern, install in a contained area with a floor drain.
- Install the appliance in a location that stays above freezing. Normal operating ambient temperature must be within 45°F to 100°F (7°C to 38°C).
- Level the ice dispenser/ice storage bin prior to installing the icemaker. After icemaker installation, confirm the icemaker is level. An out-of-level icemaker could result in improper operation, poor performance, water leaks, and/or damage to the icemaker.
- Do not leave the appliance on during extended periods of non-use, extended absences, or in sub-freezing temperatures. To properly prepare the appliance for these occasions, follow the instructions in "V. Preparing the Appliance for Periods of Non-Use."
- If water collects in the bin and will not drain, turn off the appliance and close the water supply line shut-off valve. Call for service.
- Do not place objects on top of the appliance.
- The dispenser unit/ice storage bin is for ice use only. Do not store anything else in the dispenser unit/ice storage bin.
- Protect the floor when moving the appliance to prevent damage to the floor.

I. Specifications

A. Electrical and Refrigerant Data

The rating label and nameplate provide electrical and refrigerant data and Year of Manufacture (YOM). The rating label can be seen by removing the front panel. The nameplate is located on the rear panel. For certification marks, see the nameplate.

We reserve the right to make changes in specifications and design without prior notice.

Model Number	KM-322MAK	KM-522MAK	KM-622MAK
AC SUPPLY VOLTAGE	~115/60/1	~115/60/1	~115/60/1
COMPRESSOR	115V 7.1RLA 50LRA	115V 8.7RLA 49.5LRA	115V 11.8RLA 72LRA
PUMP	120V 0.5FLA 10W	120V 0.5FLA 10W	120V 0.5FLA 10W
FAN	125V 1.0FLA 1/15 HP	125V 1.0FLA 1/15 HP	125V 1.0FLA 1/15 HP
OTHER	115V 0.10A	115V 0.10A	115V 0.10A
MAXIMUM FUSE SIZE	15 AMPS	20 AMPS	20 AMPS
MAX. HACR BREAKER (USA ONLY)	15 AMPS	20 AMPS	20 AMPS
MAX. CIRCUIT BREAKER (CANADA ONLY)	15 AMPS	20 AMPS	20 AMPS
MINIMUM CIRCUIT AMPACITY	15 AMPS	20 AMPS	20 AMPS
DESIGN PRESSURE kPa (PSI)	HI-2730 (396) LO-897 (130)	HI-2730 (396) LO-897 (130)	HI-2730 (396) LO-897 (130)
REFRIGERANT G (OZ.)	R-290 145 (5.1)	R-290 150 (5.3)	R-290 150 (5.3)
CLIMATIC CLASS	5	5	5
INSULATION BLOWING GAS	HFO 1233zd(E)	HFO 1233zd(E)	HFO 1233zd(E)
MINIMUM ROOM FLOOR AREA M ² (FT ²)	6.9 (74.7)	7.2 (77.3)	7.2 (77.3)
HARVEST RATE	≤1,000 LB/DAY (BATCH)	≤1,000 LB/DAY (BATCH)	≤1,000 LB/DAY (BATCH)

Model Number	KM-330MAK	KM-530MAK	KM-730MAK
AC SUPPLY VOLTAGE	~115/60/1	~115/60/1	~115/60/1
COMPRESSOR	115V 6.9RLA 45.0LRA	115V 9.1RLA 49.5LRA	115V 10.5RLA 72.0LRA
PUMP	115V 0.46FLA 49W	115V 0.46FLA 49W	115V 0.46FLA 49W
FAN	115V 1.0FLA 1/15 HP	115V 1.0FLA 1/15 HP	115V 0.9FLA 1/15 HP
OTHER	115V 0.15A	115V 0.15A	115V 0.15A
MAXIMUM FUSE SIZE	15 AMPS	20 AMPS	20 AMPS
MAX. HACR BREAKER (USA ONLY)	15 AMPS	20 AMPS	20 AMPS
MAX. CIRCUIT BREAKER (CANADA ONLY)	15 AMPS	20 AMPS	20 AMPS
MINIMUM CIRCUIT AMPACITY	15 AMPS	20 AMPS	20 AMPS
DESIGN PRESSURE kPa (PSI)	HI-2730 (396) LO-945 (137)	HI-2730 (396) LO-945 (137)	HI-2730 (396) LO-945 (137)
REFRIGERANT G (OZ.)	R-290 150 (5.3)	R-290 150 (5.3)	R-290 300 (10.6)
CLIMATIC CLASS	5	5	5
INSULATION BLOWING GAS	HFO 1233zd(E)	HFO 1233zd(E)	HFO 1233zd(E)
MINIMUM ROOM FLOOR AREA M ² (FT ²)	7.2 (77.3)	7.2 (77.3)	14.4 (154.4)
HARVEST RATE	≤1,000 LB/DAY (BATCH)	≤1,000 LB/DAY (BATCH)	≤1,000 LB/DAY (BATCH)

Model Number	KM-930MAK2	KM-1130MAK2
AC SUPPLY VOLTAGE	~208-230/60/1	~208-230/60/1
COMPRESSOR	208-230V 5.5RLA 35LRA	208-230V 8.3RLA 55LRA
PUMP	120V 1.2FLA 60W	120V 1.2FLA 60W
FAN	115-120V 0.9-1.0FLA 1/15 HP	115-120V 0.90FLA 1/15 HP
OTHER	115-120V 0.3A	115-120V 0.3A
MAXIMUM FUSE SIZE	20 AMPS	20 AMPS
MAX. HACR BREAKER (USA ONLY)	20 AMPS	20 AMPS
MAX. CIRCUIT BREAKER (CANADA ONLY)	20 AMPS	20 AMPS
MINIMUM CIRCUIT AMPACITY	20 AMPS	20 AMPS
DESIGN PRESSURE kPa (PSI)	HI-1800 (261) LO-1248 (181)	HI-322 (467) LO-1724 (250)
REFRIGERANT g (oz.)	R-290 395 (13.9)	R-448A 1250 (44.1)
CLIMATIC CLASS	5	5
INSULATION BLOWING GAS	HFO 1233zd(E)	HFO 1233zd(E)
MINIMUM ROOM FLOOR AREA m ² (ft ²)	18.9 (203.4)	Not Applicable
HARVEST RATE	≤1,000 LB/DAY (BATCH)	≤1,000 LB/DAY (BATCH)

Note: Climatic Class 5: This appliance electrical safety tested for operation in maximum ambient temperature of 104°F (40°C) with 40% relative humidity. However, normal operating ambient temperature must be within 45°F to 100°F (7°C to 38°C); Normal operating water temperature must be within 45°F to 90°F (7°C to 32°C). Operation of the appliance, for extended periods, outside of these normal temperature ranges may affect appliance performance.

B. Dimensions/Connections

1. Air-Cooled Models (KM-322_522_622MAK)

Units: mm [in.]

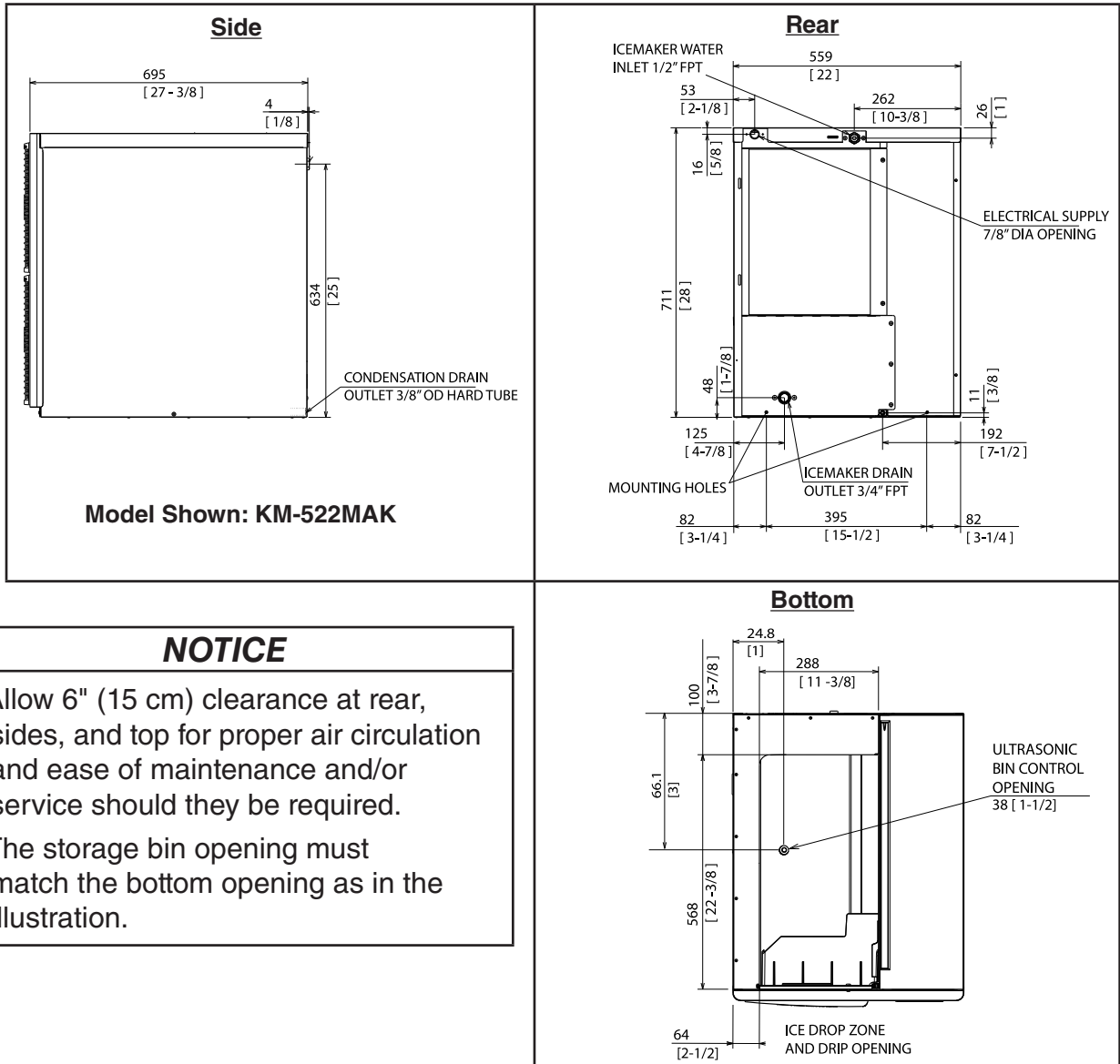

NOTICE

- Allow 6" (15 cm) clearance at rear, sides, and top for proper air circulation and ease of maintenance and/or service should they be required.
- The storage bin opening must match the bottom opening as in the illustration.

3. Air-Cooled Models (KM-930MAK2 and KM-1130MAK2)

Units: mm [in.]

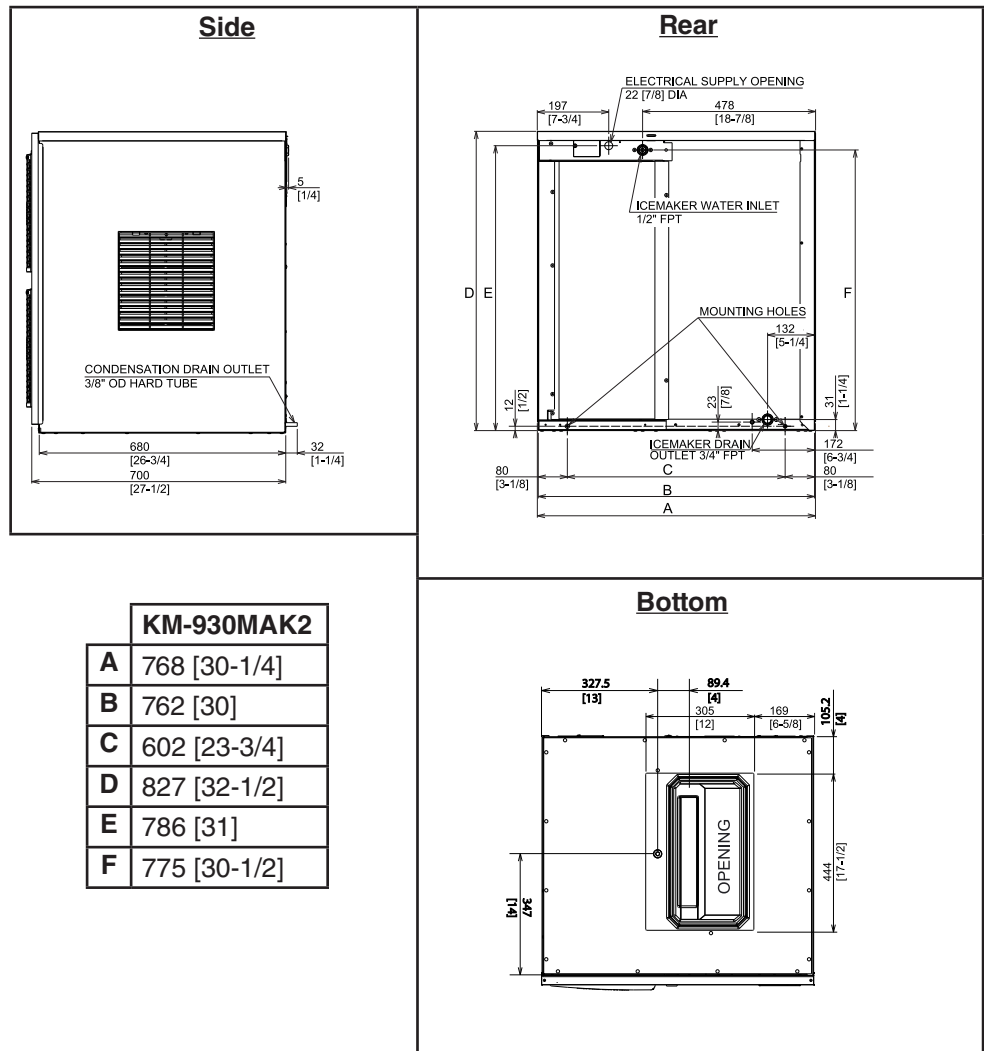

KM-930MAK2	
A	768 [30-1/4]
B	762 [30]
C	602 [23-3/4]
D	827 [32-1/2]
E	786 [31]
F	775 [30-1/2]

NOTICE

- Allow 12" (30 cm) clearance at rear, sides, and top for proper air circulation and ease of maintenance and/or service should they be required.
- The ice storage bin opening must match the bottom opening as in the illustration.

II. Installation Instructions



WARNING

- This appliance must be installed in accordance with applicable national, state, and local codes and regulations.
- This appliance to be installed in accordance with the Safety Standard for Refrigeration Systems ANSI/ASHRAE 15.
- Failure to install, operate, and maintain the appliance in accordance with this manual will adversely affect safety, performance, component life, and warranty coverage and may result in costly water damage.
- **CHOKING HAZARD:** Ensure all components, fasteners, and thumbscrews are securely in place after installation. Make sure that none have fallen into the ice storage bin.

A. Location

1. General

This appliance uses an A3 flammable refrigerant. For refrigerant charge and minimum room floor area, see the table below.

⚠ DANGER		
	R-290 Class A3 Flammable Refrigerant Used	
Model	R-290 Refrigerant Charge g (oz.)	Minimum Room Floor Area (operating or storage) Superficie Minimale du Local (service ou stockage) m ² (ft ²); m ² (pi ²)
KM-322MAK	145 (5.1)	6.9 (74.7)
KM-522MAK, KM-622MAK, KM-330MAK, KM-530MAK	150 (5.3)	7.2 (77.3)
KM-730MAK	300 (10.6)	14.4 (154.4)
KM-930MAK2	395 (13.9)	18.9 (203.4)
 <p>≥ Area m² (ft²) (see "Minimum Room Floor Area" above) ≥ Superficie m² (pi²) (voir « Superficie Minimale du Local » ci-dessus)</p>		
⚠ DANGER continued		
<p>R-290 Refrigerant Charge:</p> <ul style="list-style-type: none"> • If greater than 114 g (4 oz.), do not install in public corridor or lobby. • If greater than 152 g (5.3 oz.), do not install within 6 m (20 ft) of open flame. <p>Charge de réfrigérant R-290:</p> <ul style="list-style-type: none"> • Si elle est supérieure à 114 g (4 oz.), ne pas l'installer dans un couloir public ou un hall d'entrée. • Si elle est supérieure à 152 g (5.3 oz.), ne pas l'installer à moins de 6 m (20 pi) d'une flamme nue. 		
This appliance is intended for use at altitudes up to 7,000 m (22,965 ft).		

NOTICE

- The appliance is not intended for outdoor use. Normal operating ambient temperature must be within 45°F to 100°F (7°C to 38°C); Normal operating water temperature must be within 45°F to 90°F (7°C to 32°C). Operation of the appliance, for extended periods, outside of these normal temperature ranges may affect appliance performance.
- This appliance will not work at sub-freezing temperatures. To prevent damage to the water supply line, drain the appliance if the air temperature is going to go below 32°F (0°C). See "V. Preparing the Appliance for Periods of Non-Use."
- Install the appliance in a location that is flat. The ice storage bin has adjustable legs, adjust to level as needed. Be sure the appliance is properly leveled to avoid improper operation, faulty system performance, and possible appliance damage.

- The appliance should not be located next to ovens, grills, or other high heat producing equipment.
- The location should provide a firm and level foundation for the appliance.
- For all models except KM-930MAK2 and KM-1130MAK2, allow 6" (15 cm) clearance at rear, sides, and top for proper air circulation and ease of maintenance and/or service should they be required.
For KM-930MAK2 and KM-1130MAK2 models, allow 12" (30 cm) clearance at rear, sides, and top for proper air circulation and ease of maintenance and/or service should they be required.

B. Checks Before Installation

- Visually inspect the exterior of the shipping container and immediately report any damage to the carrier. Upon opening the container, any concealed damage should also be immediately reported to the carrier.
- Remove the shipping carton, tape, and packing material. If any are left in the appliance, it will not work properly.
- See the nameplate on the rear panel, and check that your voltage supplied corresponds with the voltage specified on the nameplate.
- Remove the panels to prevent damage when installing the appliance. See "II.C. How to Remove Panels."
- Remove the package containing the accessories.
- Remove the protective plastic film from the panels. If the appliance is exposed to the sun or to heat, remove the film after the appliance cools.
- Check that the refrigerant lines do not rub or touch lines or other surfaces, and that the fan blade(s) (if applicable) turn freely.
- Check that the compressor is snug on all mounting pads.
- The icemaker can be installed on a dispenser unit or ice storage bin. The ice storage bins listed below are recommended.

⚠ DANGER

Models utilizing R-290 refrigerant shall be used on a dispenser unit/ice storage bin without electrical components or one designed to be used with flammable refrigerants, and of a size or type as indicated in this manual. See the nameplate or the Electrical and Refrigerant Data section of this manual for the refrigerant type in your model.

Model Number	Bin Width	Recommended Hoshizaki Ice Storage Bin
KM-322MAK, KM-522MAK, KM-622MAK	22" or Wider	BD-300 Series
KM-330MAK, KM-530MAK, KM-730MAK KM-930MAK2, KM-1130MAK2	30" or Wider	BD-500 Series

For further options, contact your local Hoshizaki distributor.

C. How to Remove Panels

See Fig. 1

- Front Panel: Remove the screw. Lift up and towards you.
- Top Panel: Lift up at front slightly, push rearward, then lift off.
- Right Side Panel: Remove the screw. Slide forward slightly and lift off.
- Top Insulation Panel: Pull forward slightly, then lift off.
- Front Insulation Panel: From the top, pull forward slightly, then lift off.

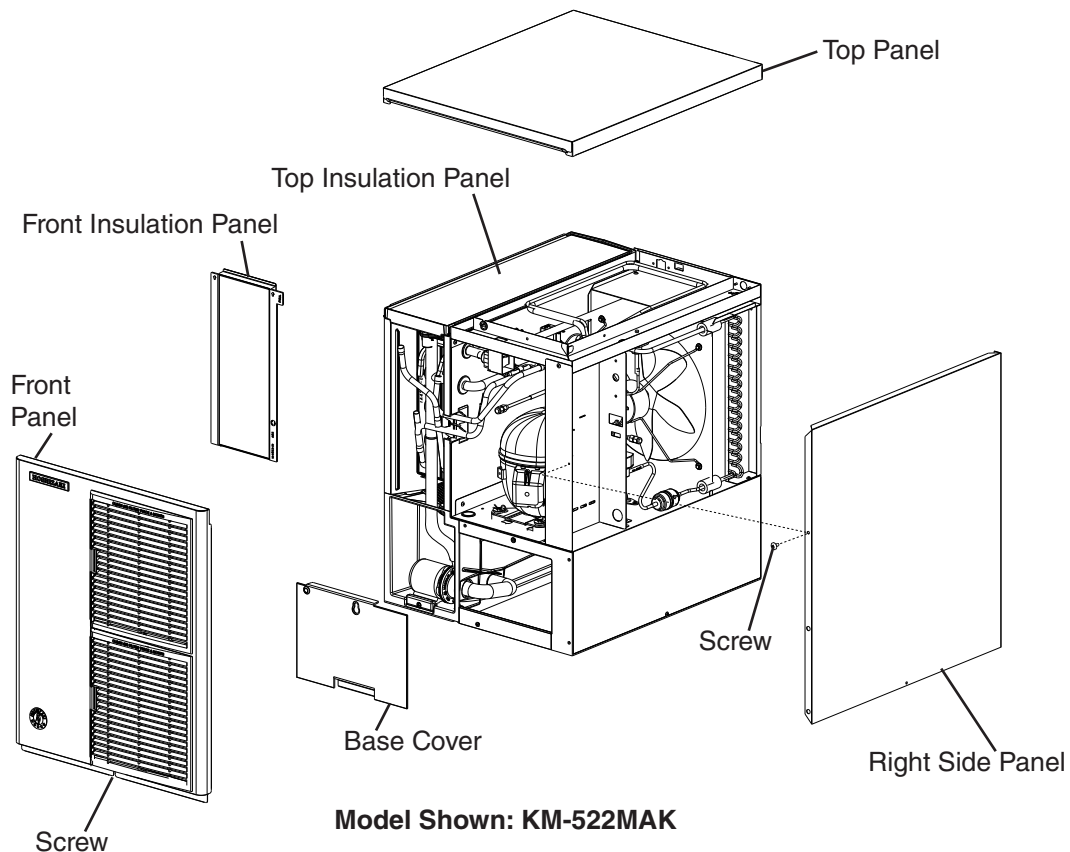

Fig. 1

D. Dispenser Unit/Ice Storage Bin and Icemaker Setup

⚠ DANGER

Models utilizing R-290 refrigerant shall be used on a dispenser unit/ice storage bin without electrical components or one designed to be used with flammable refrigerants, and of a size or type as indicated in this manual. See the nameplate or the Electrical and Refrigerant Data section of this manual for the refrigerant type in your model.

⚠ WARNING

- The installer must ensure the dispenser unit/ice storage bin is compatible with the icemaker, and the dispenser unit/ice storage bin and icemaker are properly attached and secured.
- Do not allow top kits to interfere with the bin control lens sensing area or the icemaker will not operate properly.

- 1a) **Dispenser Unit:** Follow the dispenser unit's setup procedure.
- 1b) **Ice Storage Bin:** Unpack the ice storage bin and attach the 4 adjustable legs provided (bin accessory) to the bottom of the ice storage bin.
- 2) Position the dispenser unit/ice storage bin in its permanent location.
- 3) If required, install an adapter kit or top kit. Contact your local Hoshizaki distributor for recommendations.
- 4) Level the dispenser unit/ice storage bin in both the left-to-right and front-to-rear directions. If using an ice storage bin, adjust the ice storage bin legs to level.
- 5) Place the icemaker on top of the dispenser unit/ice storage bin.
- 6a) **Dispenser Unit:** Follow the dispenser unit, adapter kit, or top kit instructions for securing the icemaker. If no instructions are available, secure the icemaker using the mounting brackets provided. Rotate the mounting brackets so that they fit flush to the dispenser unit. See Fig. 2a. Secure the mounting brackets to the icemaker with the bolts provided. Secure the mounting brackets to the dispenser unit with self-tapping screws (not provided). **NOTICE! Use care to avoid damage to dispenser unit components when attaching the mounting brackets. For dispenser unit bin control setting, see "III.B.1. Bin Control Setting."**
- 6b) **Ice Storage Bin:** Follow the ice storage bin, adapter kit, or top kit instructions for securing the icemaker. If no instructions are available, secure the icemaker using the 2 mounting brackets and the bolts provided. See Fig. 2b.

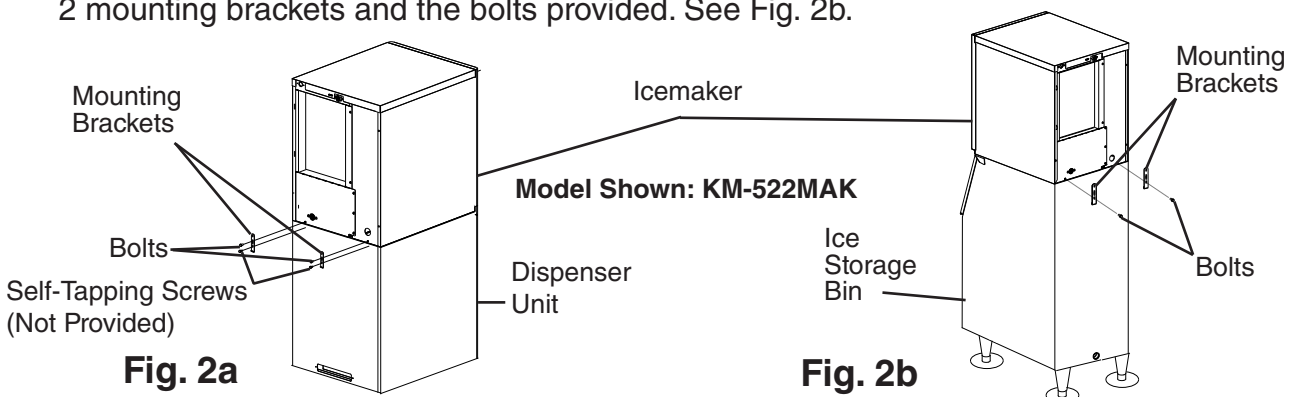

E. Electrical Connection

⚠ WARNING

For All Models

- Electrical connection must be hard-wired and must meet national, state, and local electrical code requirements. Failure to meet these code requirements could result in death, electric shock, serious injury, fire, or damage.
- The appliance requires an independent power supply of proper capacity. See the nameplate for electrical specifications. Failure to use an independent power supply of proper capacity can result in a tripped breaker, blown fuse, damage to existing wiring, or component failure. This could lead to heat generation or fire.
- **THE APPLIANCE MUST BE GROUNDED.** Failure to properly ground the icemaker could result in death or serious injury.
- Electrical connection must be made in accordance with the instructions on the "WARNING" tag, provided with the pig tail leads in the junction box. See Figs. 3a and 3b.
- To reduce the risk of electric shock, do not touch the control switch or mode switch with damp hands.

- Usually an electrical permit and services of a licensed electrician are required.
- The maximum allowable voltage variation is ± 6 percent of the nameplate rating.
- The opening for the power supply connection is 7/8" DIA. to fit a 1/2" trade size conduit.
- On 115VAC models, the white lead must be connected to the neutral conductor of the power source. **NOTICE! Miswiring may result in severe damage to the icemaker.**
- **NOTICE! On KM-930MAK2 and KM-1130MAK2 models, the main transformer's voltage tap switch must be positioned to match incoming voltage at startup.**

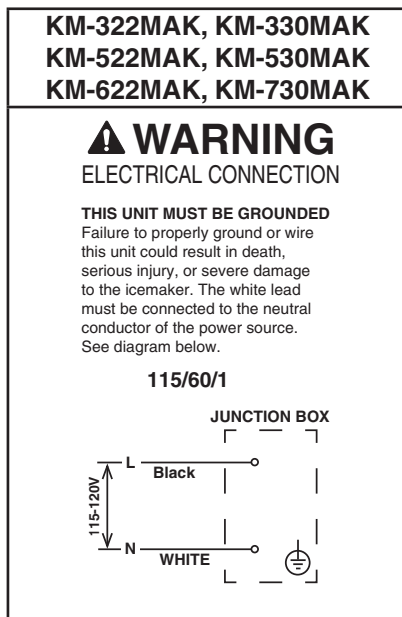

Fig. 3a

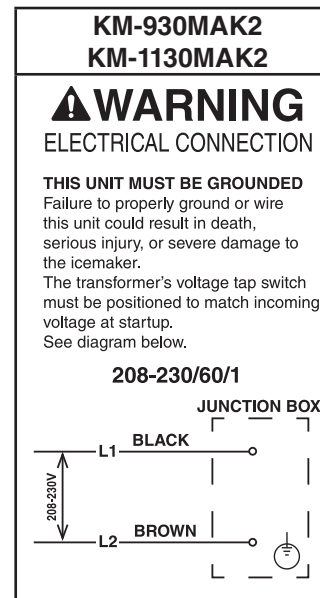

Fig. 3b

F. Water Supply and Drain Connections

See Fig. 4

⚠ WARNING

- Water supply and drain connections must be installed in accordance with applicable national, state, and local regulations.
- Connect to potable water supply only. Do not connect to a hot-water supply.

NOTICE

- Water supply line size is critical to the operation of the appliance. Failure to provide adequate water supply to the appliance may result in damage to the appliance, damage to property, and may void the warranty.
- Normal operating water temperature must be within 45°F to 90°F (7°C to 32°C). Operation of the appliance, for extended periods, outside of this normal temperature range may affect appliance performance.
- Water supply pressure must be a minimum of 10 PSIG (68 kPaG) and a maximum of 113 PSIG (779 kPaG). If the pressure exceeds 113 PSIG (779 kPaG), the use of a pressure reducing valve is required.
- External filters, strainers, or softeners may be required depending on water quality. Contact your local Hoshizaki Certified Service Representative or local Hoshizaki distributor for recommendations.
- In areas where water damage is a concern, install in a contained area with a floor drain.
- Water line installation to the appliance is not warranted by Hoshizaki.
- Be sure there is sufficient extra water supply line and drain line for the appliance to be pulled out for service.
- Water-hammer issues must be resolved by a qualified plumber before installing the appliance. Water hammer can cause appliance damage that may lead to water leakage or flooding.
- A minimum of 3/4" nominal ID hard pipe or equivalent is required for the drain line. Installing a smaller diameter drain line will reduce water flow and may lead to water leakage or flooding.
- To prevent damage to the appliance, do not operate the appliance when the water supply is off, or if the pressure is below 10 PSIG (68 kPaG). Do not run the appliance until the proper water pressure is reached.

- A plumbing permit and services of a licensed plumber may be required in some areas.
- The icemaker drain line, dispenser unit/ice storage bin drain line, and water-cooled condenser drain line (if applicable) must be run separately.
- Drain lines must have 1/4" fall per foot (2 cm per 1 m) on horizontal runs to provide a proper drain flow. A vented tee connection is also required for proper flow.
- Drain lines should not be piped directly to the sewer system. An air gap of a minimum of 2 vertical inches (5 cm) should be between the end of the drain pipes from the icemaker, dispenser unit/ice storage bin, and water-cooled condenser (if applicable) and the floor drain.

1. Icemaker

MODEL	Icemaker Water Supply Inlet	Minimum Icemaker Water Supply Line Size	Icemaker Drain Outlet	Minimum Icemaker Drain Line Size
All Except KM-930MAK2 KM-1130MAK2	1/2" Female Pipe Thread (FPT)	1/4" Nominal ID Copper Water Tubing or Equivalent	3/4" Female Pipe Thread (FPT)	3/4" Nominal ID Hard Pipe or Equivalent
KM-930MAK2 KM-1130MAK2		3/8" Nominal ID Copper Water Tubing or Equivalent		

- A water supply line shut-off valve and drain valve must be installed.

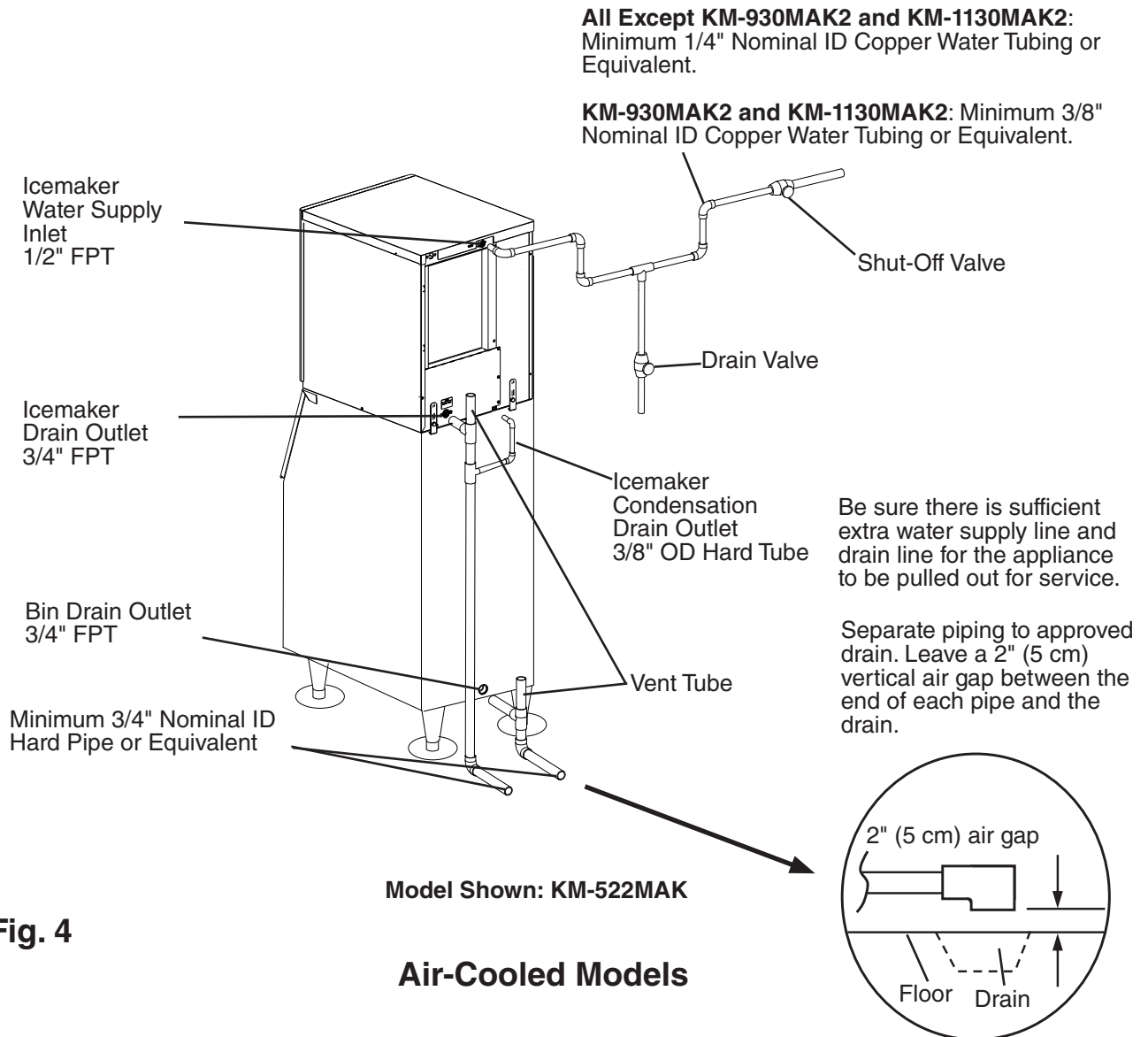

Fig. 4

G. Final Checklist

1. Pre-Startup

- 1) Is the appliance level?
- 2) Is the appliance in a site where the ambient temperature is within 45°F to 100°F (7°C to 38°C) and the water temperature within 45°F to 90°F (7°C to 32°C) all year around?
- 3) For all models except KM-930MAK2 and KM-1130MAK2, is there at least 6" (15 cm) clearance at rear, sides, and top of the appliance?
For KM-930MAK2 and KM-1130MAK2 models, is there at least 12" (30 cm) clearance at rear, sides, and top of the appliance?
- 4) Have the shipping carton, tape, and packing material been removed from the appliance? Are the cube guide(s) in their correct positions?
- 5) Has the protective plastic film been removed from the panels?
- 6) Have all electrical and water connections been made? Do electrical and water connections meet applicable national, state, and local code and regulation requirements?
- 7) Has the power supply voltage been checked or tested against the nameplate rating? Has a proper ground been installed to the appliance? **Has the KM-930MAK2 and KM-1130MAK2 models main transformer's voltage tap switch been positioned to match incoming voltage.**
- 8) Are the water supply and drain lines sized as specified? Are the water supply line shut-off valve(s) and drain valve(s) installed? Has the water supply pressure been checked to ensure a minimum of 10 PSIG (68 kPaG) and a maximum of 113 PSIG (779 kPaG)?
- 9) Is the compressor snug on all mounting pads? Have the refrigerant lines been checked to make sure they do not rub or touch other lines or surfaces? Have the fan blade(s) (if applicable) been checked to make sure they turn freely?
- 10) Continue to "III. Operating Instructions."

2. Post-Startup

⚠ WARNING
CHOKING HAZARD: Ensure all components, fasteners, and thumbscrews are securely in place after installation. Make sure that none have fallen into the dispenser unit/ice storage bin.

- 1) Has the bin control been set to the proper setting for the application?
- 2) Has the bin control operation been confirmed?
- 3) Are all components, fasteners, and thumbscrews securely in place?
- 4) Has the end user been given the instruction manual, and instructed on how to operate the appliance and the importance of the recommended periodic maintenance?
- 5) Has the end user been given the contact information of an authorized service agent?
- 6) Has the warranty registration been completed and submitted to the factory?

III. Operating Instructions

Models covered in this manual utilize either R-290 or R-448A refrigerant.



R-290 Class A3 Flammable Refrigerant Used*

⚠ DANGER

Risk of Fire or Explosion. Flammable Refrigerant Used.*

- Be sure to follow all Important Safety Information located at the beginning of this manual.
- Failure to install, operate, and maintain the appliance in accordance with this manual will adversely affect safety, performance, component life, and warranty coverage and may result in costly water damage.
- Keep clear of obstruction all ventilation openings in the appliance enclosure or in the structure for building-in.

Risque D'Incendie ou D'Explosion. Fluide Frigorigène Inflammable Utilisé.*

- Veuillez à respecter toutes les consignes de sécurité importantes figurant au début de ce manuel.
- Le fait de ne pas installer, utiliser et entretenir l'appareil conformément à ce manuel aura des conséquences négatives sur la sécurité, les performances, la durée de vie des composants et la couverture de la garantie, et peut entraîner des dégâts des eaux coûteux.
- Ne pas obstruer les ouvertures de ventilation dans l'enceinte de l'appareil ou dans la structure d'encastrement.

A. Important Notes About Usage

NOTICE

- Protect the floor when moving the appliance to prevent damage to the floor.
- Do not leave the appliance on during extended periods of non-use, extended absences, or in sub-freezing temperatures. To properly prepare the appliance for these occasions, follow the instructions in "V. Preparing the Appliance for Periods of Non-Use."
- Do not place objects on top of the appliance.
- The dispenser unit/ice storage bin is for ice use only. Do not store anything else in the dispenser unit/ice storage bin.
- If applicable, keep ventilation openings in the appliance clear of obstruction.

*This statement applies to models utilizing R-290 refrigerant. See the nameplate or the Electrical and Refrigerant Data section of this manual for the refrigerant type in your model.

*Cette déclaration s'applique aux modèles utilisant le réfrigérant R-290. Consultez la plaque signalétique ou la section Données électriques et de réfrigérant de ce manuel pour connaître le type de réfrigérant de votre modèle.

B. Startup

1. Bin Control Setting

An ultrasonic sensor is used as the bin control to control the level of ice in the dispenser unit/ice storage bin. The bin control setting must be set to match the application to avoid possible icemaker movement, water leakage, or ice overflow.

⚠ DANGER

Models utilizing R-290 refrigerant shall be used on a dispenser unit/ice storage bin without electrical components or one designed to be used with flammable refrigerants, and of a size or type as indicated in this manual. See the nameplate or the Electrical and Refrigerant Data section of this manual for the refrigerant type in your model.

⚠ WARNING

- All parts are factory-adjusted. Improper adjustments may adversely affect safety, performance, component life, and warranty coverage.
- To reduce the risk of electric shock, do not touch the control switch or mode switch with damp hands.
- Improper adjustment may adversely affect safety, performance, component life, and warranty coverage.
- On dispenser unit applications, do not increase ice level above the recommended setting listed below. Higher ice levels could result in icemaker movement, water leakage, or ice overflow.
- Risk of electric shock. Control switch in "OFF" position does not de-energize all loads. Note: On KM-930MAK2 models fan motor runs with control switch in the "OFF" position. Disconnect or breaker must be turned off to de-energize fan motor.

NOTICE

- If the appliance is turned off, wait for at least 3 min. before restarting the appliance to prevent damage to the compressor.
- At startup, confirm that all internal and external connections are free of leaks.
- Do not allow top kits or top kit risers (if applicable) to interfere with the bin control lens sensing area or the icemaker will not operate properly.

- 1) Move the control switch to the "OFF" position. Make sure the power supply is off to the icemaker. If not already removed, remove the top panel and control box cover. Note: For **KM-322_522_622MAK** also remove the base cover. See Fig. 5. If front access to the control box is required, remove the control box mounting screws, then slide the control box forward and rotate the control box for access. See Fig. 6.

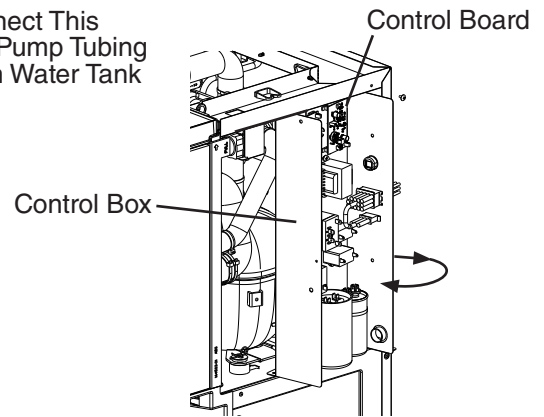
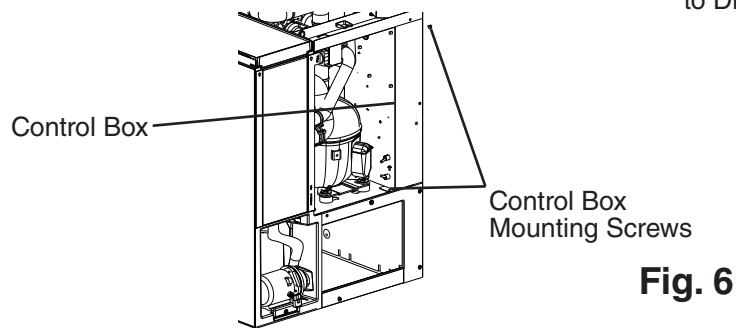
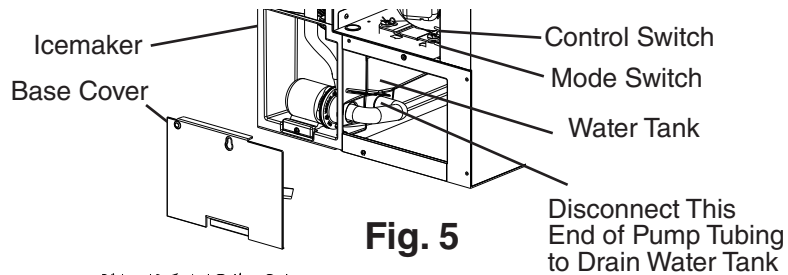

- 2) Confirm the correct control board bin control setting required for your application and adjust according to the following tables. See Fig. 7 through Fig. 10.

For Standard Ice Storage Bins, Hoshizaki DB and DM Dispenser Units, and Coca-Cola Freestyle® Dispenser Units. See Figs. 7 and 8.

Application	Bin Control Ice Level Settings	
	Bin Control Setting	Shutdown Distance From Ultrasonic Bin Control Lens (Restart is 4 in. (102 mm) below shutdown distance)
Standard Ice Storage Bins	1 (Factory Default)	304 mm (12") Do not adjust dispensers to this setting.
Hoshizaki DB and DM Dispensers	2	335 mm (13")
Coca-Cola Freestyle® Dispensers	3	416 mm (16 3/8")
Optional Setting	4	522 mm (20.5")
	5	610 mm (24")

⚠ WARNING

Confirm that the final ice level location does not allow for icemaker movement, water leakage, or ice overflow.

a) **KM-322_522_622MAK.** See Fig. 7.

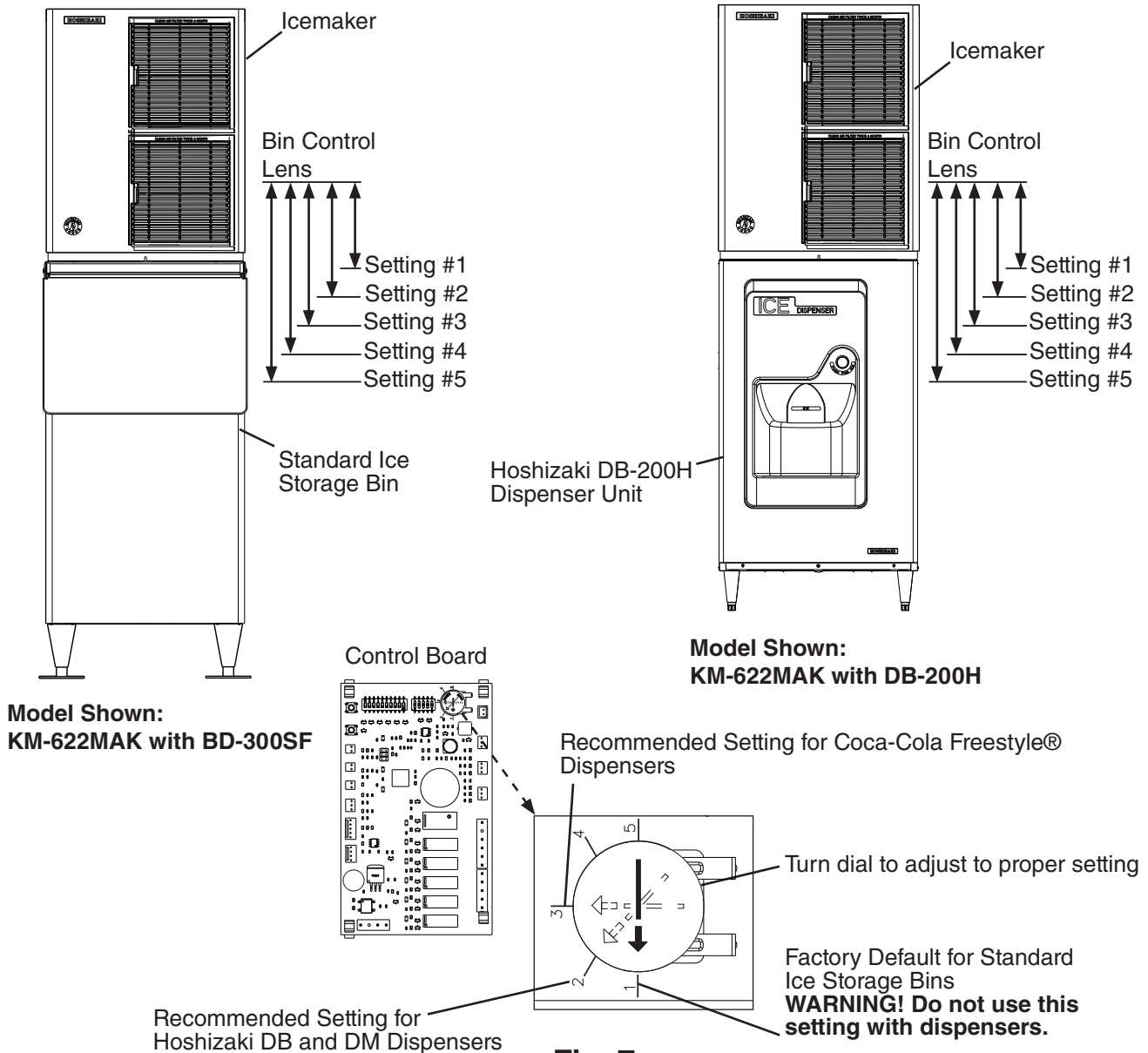
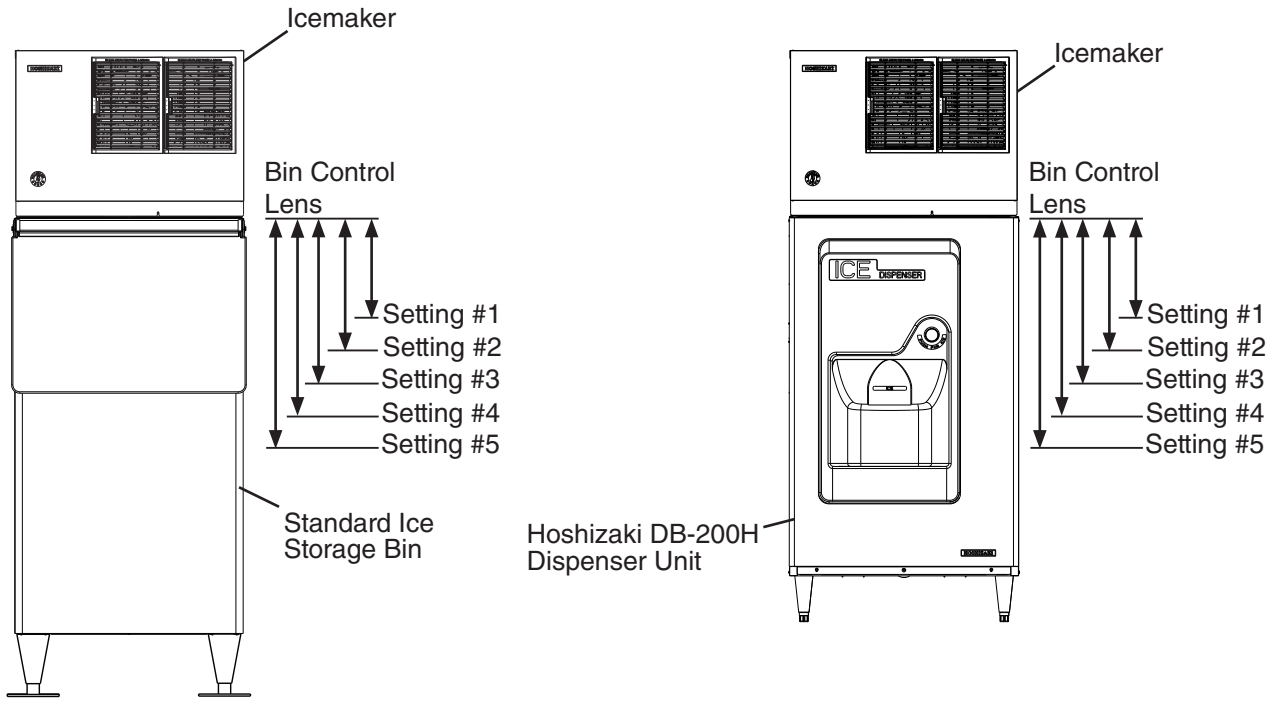

Fig. 7

b) KM-330_530_730MAK, KM-930MAK2, and KM-1130MAK2. See Fig. 8.



Model Shown:
KM-530MAK with DB-200H

Model Shown:
KM-530MAK with BD-500SF

Control Board

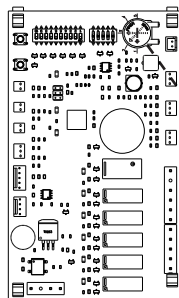

Recommended Setting for Coca-Cola Freestyle®
Dispensers

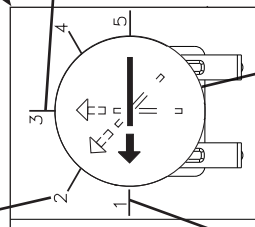

Turn dial to adjust to proper setting

Factory Default for Standard
Ice Storage Bins
**WARNING! Do not use this
setting with dispensers.**

Recommended Setting for
Hoshizaki DB and DM Dispensers

Fig. 8

For Non-Hoshizaki Dispenser Units. See Figs 9 and 10.

Bin Control Ice Level Settings	
Bin Control Setting	Shutdown Distance From Bin Control Lens (Restart is 4 in. (102 mm) below shutdown distance)
1 (Factory Default)	304 mm (12") Do not adjust dispensers to this setting.
2	335 mm (13")
3	416 mm (16 3/8")
4	522 mm (20.5")
5	610 mm (24")

⚠ WARNING

Confirm that the final ice level location does not allow for icemaker movement, water leakage, or ice overflow.

NOTICE

The ice level must be lower than the top of the dispenser unit. Also, be sure the top kit or top kit riser (if applicable) are clear from the bin control lens sensing area.

a) **KM-322_522_622MAK.** See Fig. 9.

Full Bin Measured Distance (Shutdown Distance)
Measure from the bottom of the compressor base (bin control lens) to the preferred full bin level of ice; refer to the dispenser instruction manual.

Set Bin Control Setting at or Below Maximum Full Bin Level of Ice (Shutdown Position) Shown Here

Icemaker Restart Level
(4" (102 mm) below preferred full bin level of ice)

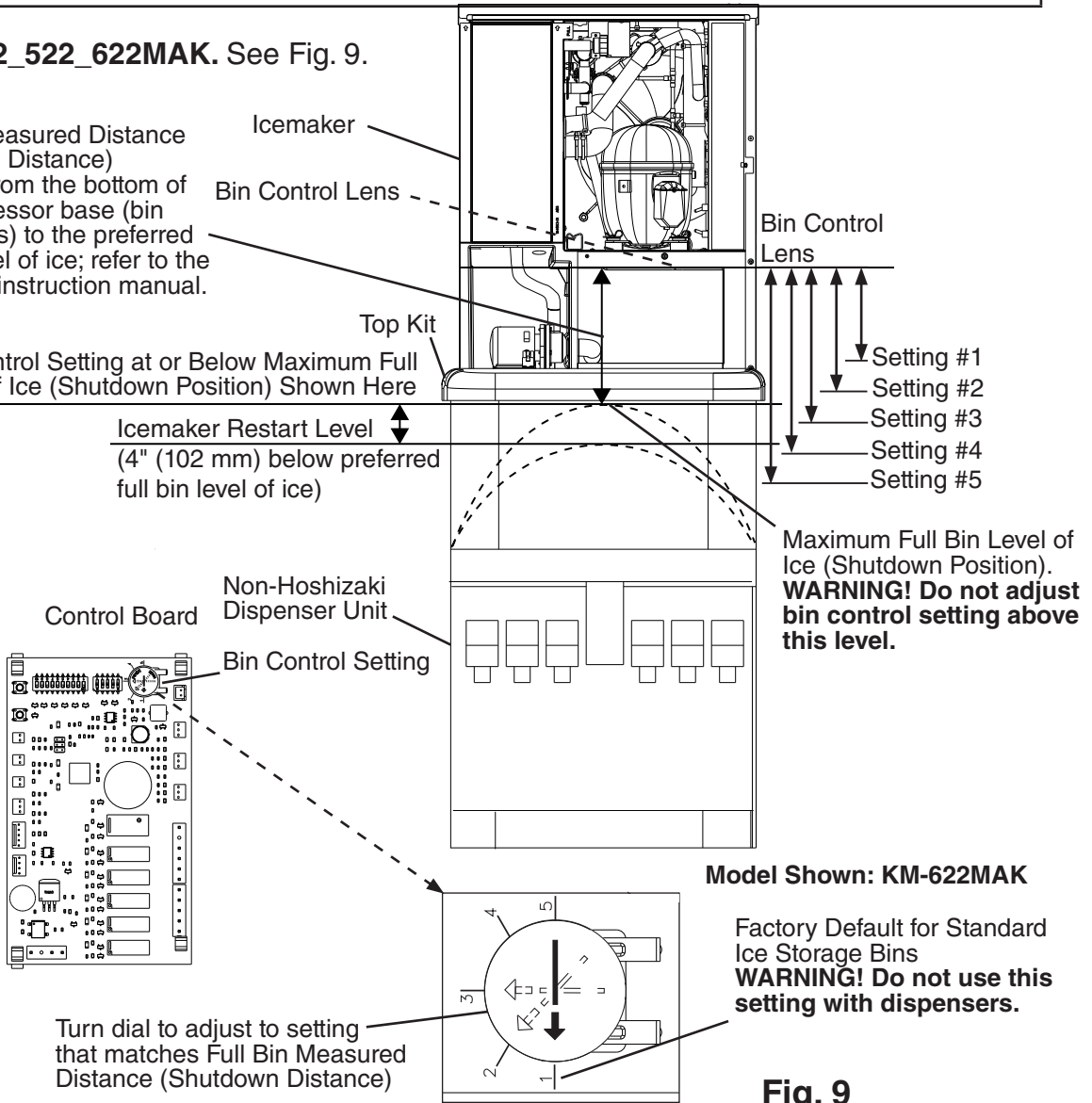

Fig. 9

b) **KM-330_530_730MAK, KM-930MAK2, and KM-1130MAK2.** See Fig. 10.

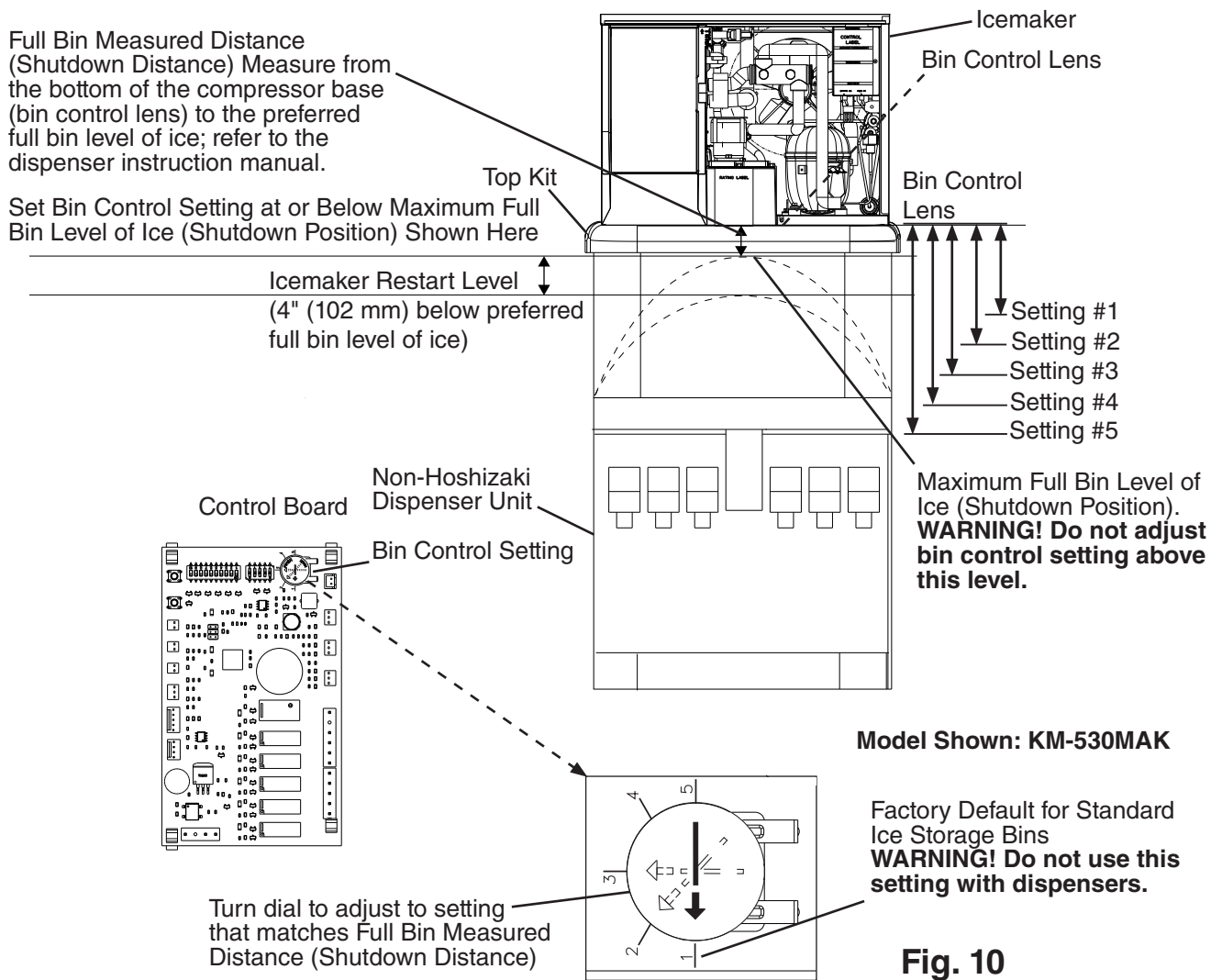

Fig. 10

2. Appliance Startup and Bin Control Check

⚠ WARNING

- All parts are factory-adjusted. Improper adjustments may adversely affect safety, performance, component life, and warranty coverage.
- Make sure the icemaker has been installed as outlined in this manual and that the water supply is on.
- Improper adjustment may adversely affect safety, performance, component life, and warranty coverage.

NOTICE

- If the icemaker is turned off, wait for at least 3 minutes before restarting the icemaker to prevent damage to the compressor.
- To prevent damage to the water pump seal, do not leave the control switch in the "PUMP" position for extended periods when the water tank is empty.
- At startup, confirm that all internal and external connections are free of leaks.
- Do not allow top kits or top kit risers (if applicable) to interfere with the bin control lens sensing area or the icemaker will not operate properly.

- 1) If not already removed, remove the front and top panels and control box cover. Make sure the bin control setting has been adjusted as outlined in "III.B.1. Bin Control Setting."
- 2) Make sure the control switch is in the "OFF" position and that the power supply is off.
- 3) Open the water supply line shut-off valve(s).
- 4) Move the mode switch on the control box to the "ICE" position, then move the control switch to the "ON" position. Turn on the power supply, and allow the icemaker to operate.
- 5) Confirm the control board "BIN CLS" LED is off (bin empty). See Fig. 11.

Ice Level in Bin	Control Board "BIN CLS" LED
Empty	OFF
Full	ON

- 6) If the control board "BIN CLS" is on (indicating a full bin), correct any interference from the top kit or top kit riser (if applicable).

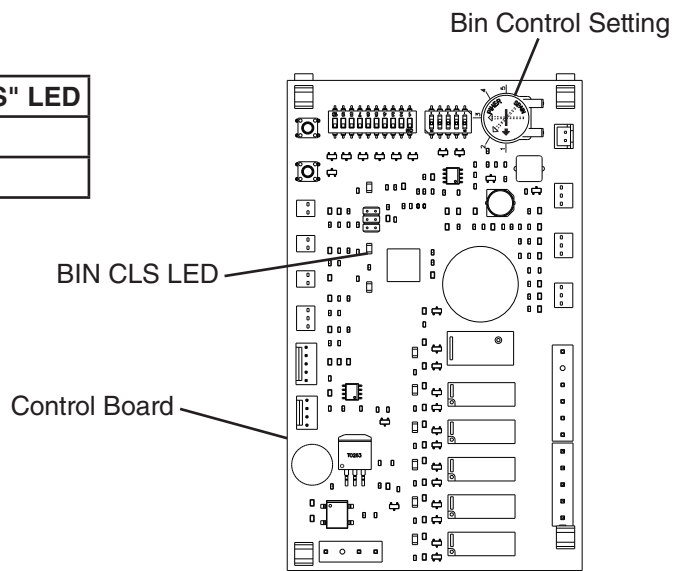

Fig. 11

7) 1 min. fill cycle begins. Place an object 5" to 7" (127 to 178 mm) away from the bin control lens. See Figs. 12a, 12b, and 12c. 15 sec. later, the icemaker shuts down. Remove the object from the bin control lens. 30 sec. later, the icemaker restarts. For bin control shutdown times per cycle, see the table below:

Cycle at Bin Control Activation	Shutdown
1 min. Fill Cycle	15 sec. after activation.
Harvest Cycle	If engaged 15 sec. or longer, at the end of harvest cycle.
Freeze Cycle	15 sec. after activation if activated at least 15 sec. before the 5-min. short cycle protection timer terminates. Otherwise, at the end of the next harvest cycle.

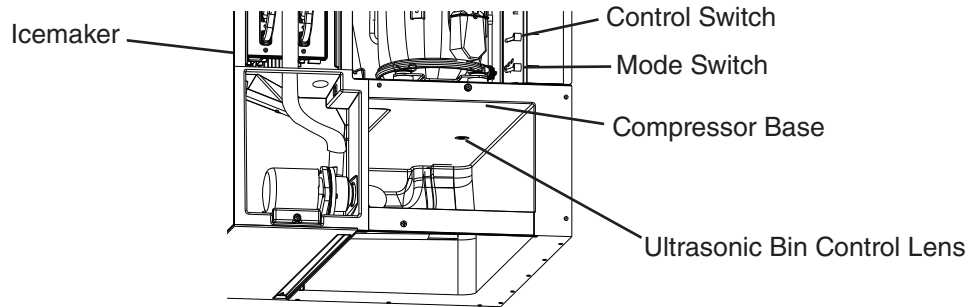

Fig. 12a

Model Shown: KM-52MAK

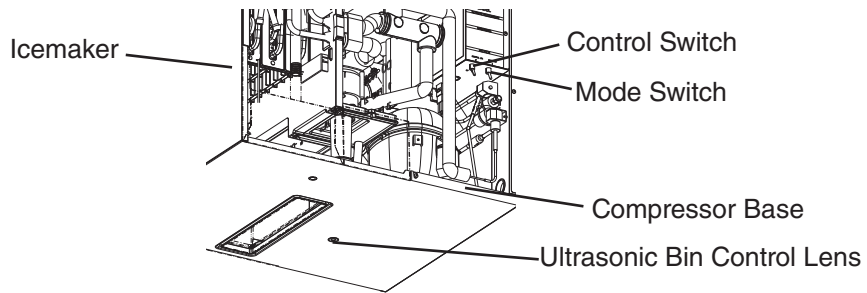

Fig. 12b

Model Shown: KM-530MAK

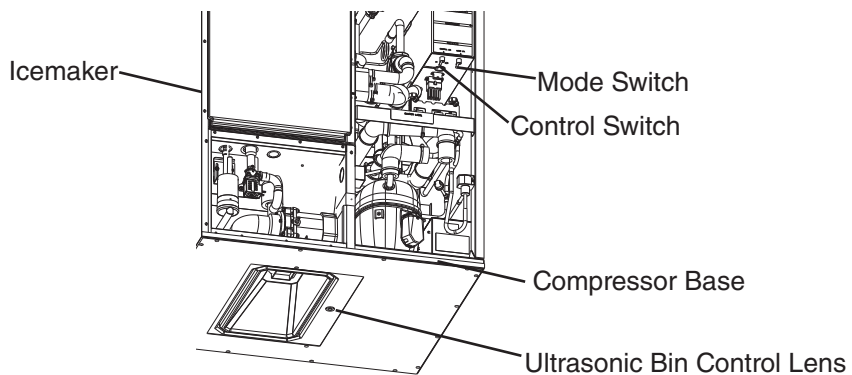

Fig. 12c

Model Shown: KM-930MAK2

- 8) Once the icemaker restarts, move the control switch to the "OFF" position, then turn off the power supply.
- 9) Replace the control box cover in its correct position and secure with the control box mounting screw.
- 10) Move the control switch to the "ON" position, then replace the top and front panels in their correct positions.
- 11) Turn on the power supply to start the automatic icemaking process, and allow the icemaker to operate for 10 min.
- 12) After 10 min., turn off the power supply, then remove the front panel.
- 13) Remove the front panel. Move the control switch to the "OFF" position, then turn off the power supply.

Drain the Tank

- 14a)(1) For **KM-322_522_622MAK** - Remove the front insulation panel, then disconnect the water tank pump tubing located behind the base cover. See Fig. 13. Allow the water tank to drain.

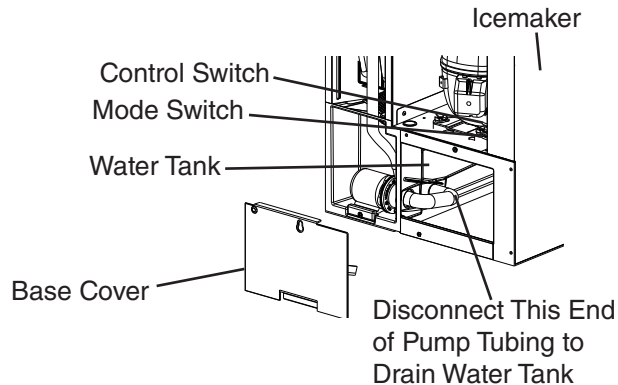

Fig. 13

- 14a)(2) After the water tank has drained, replace the water tank pump tubing and base cover back in their correct positions. Continue to step 15 below.
- 14b)(1) For **KM-330_530_730MAK** - Remove the front insulation panel, then remove the water tank drain plug located in the bottom of the water tank. See Fig. 14. Allow the water tank to drain.

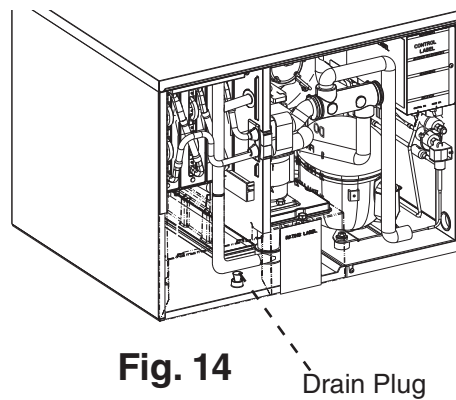

Fig. 14

- 14b)(2) After the water tank has drained, replace the drain plug back in its correct position. Continue to step 15 below.

14c)(1) For **KM-930MAK2** and **KM-1130MAK2** - Remove the splash guard and cube guide B. See Fig. 16.

Next, slide cube guide A to the right and pull forward to remove cube guide A.

NOTICE! The rear portion of cube guide A is placed outside and underneath the rear evaporator bracket. Lift the front of cube guide A and push down and pull cube guide A to slide it out from under the rear evaporator bracket.

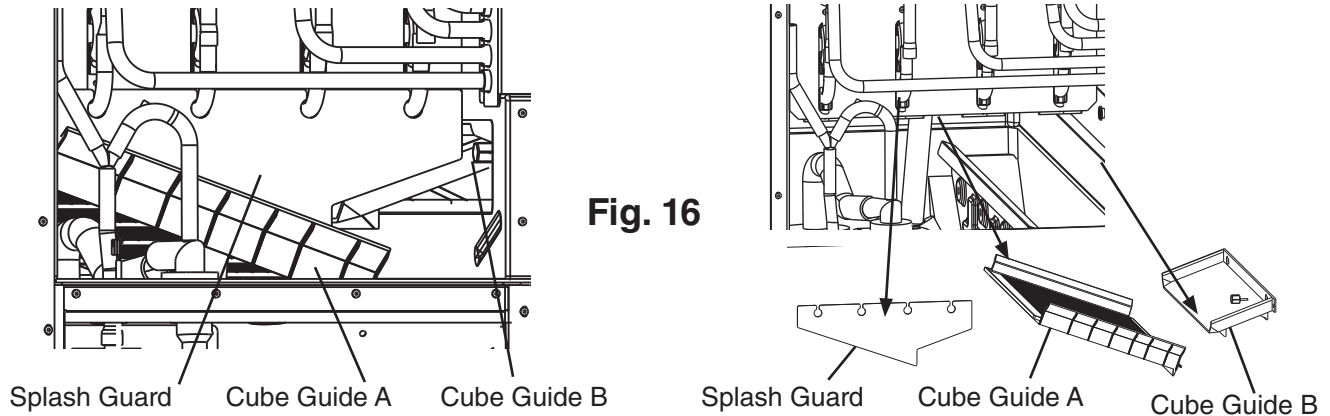

14c)(2) Remove the rubber cap and sleeve covering the overflow pipe. See Fig. 17.
Unscrew the overflow pipe.

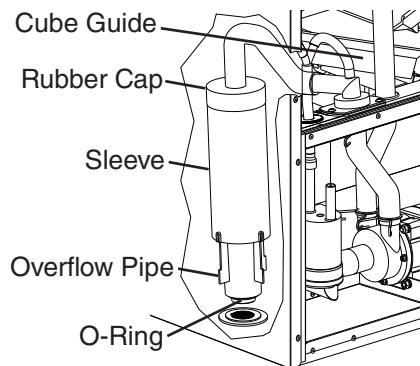

14c)(3) After the water tank has drained, replace the overflow pipe and rubber cap and sleeve in their correct positions. **NOTICE!** Make sure the O-ring is attached to the bottom of the overflow pipe and be careful not to cross thread the overflow pipe.

14c)(4) Replace cube guide A in its correct position. Continue to step 15 below.
NOTICE! The rear portion of cube guide A must be placed back to the outside of the evaporator plastic bracket to allow proper positioning of cube guide A.

15) Replace the front insulation panel in its correct position.

16) Clean the dispenser unit/ice storage bin liner using a neutral cleaner. Rinse thoroughly after cleaning.

17) Move the control switch to the "ON" position. Replace all panels in their correct positions.

18) Turn on the power supply to start the automatic icemaking process.

19) Return to "II.G.2. Post-Startup" and complete final checklist.

C. Alarm Safeties

Should an alarm occur, follow the instructions in the table below to address the alarm. If an alarm continues to occur, contact an authorized service agent. In case of alarm, the built-in safeties shut down the appliance and an audible alarm sounds as listed below.

Type	Alarm	Notes and Reset Options
1 Beep	High Evaporator Temp. (temperature > 127°F) (53°C)	Check for harvest problem (stuck HGV or relay), hot water entering unit, stuck HM, or shorted thermistor.
2 Beep	Harvest Backup Timer (harvest > 20 min. for two cycles in a row)	Check thermistor (open), HGV not opening, TXV or LLV leaking by, low charge, inefficient Comp, or WRV leaking by.
3 Beep	Freeze Timer (freeze > freeze timer setting for two cycles in a row)	Check FS stuck closed (up), WV leaking by, HGV leaking by, PM not pumping, TXV defective, LLV not opening, low charge, HM not bypassing, or inefficient Comp.
To reset above safeties, press "ALARM RESET" button with power supply on.		
6	Low Voltage (92Vac±5% or less)	Red "POWER" LED turns off if voltage protection operates.
7	High Voltage (147Vac±5% or more)	Control voltage safeties automatically reset when voltage is corrected.
"Power" LED Blink Only	Freeze Up Detection Cycle	Freeze up detection cycle initiated. "POWER" LED blinks until 6 FS activated freeze cycles completed or control board manually reset. See service manual for details.

Legend: **Comp**—compressor; **CV**—cleaning valve; **DV**—drain valve; **FM**—fan motor; **FS**—float switch; **HGV**—hot gas valve; **LLV**—liquid line valve; **PM**—pump motor; **TXV**—thermostatic expansion valve; **WRV**—water regulating valve; **WV**—inlet water valve

IV. Maintenance

The appliance must be maintained in accordance with the instruction manual and labels provided with the appliance. Consult with your local Hoshizaki Certified Service Representative about maintenance service. To obtain the name and phone number of your local Hoshizaki Certified Service Representative, visit www.hoshizakiamerica.com.

WARNING

- Items listed under "IV.A. User Maintenance Schedule" may be performed by the user; otherwise, only qualified service technicians should service the appliance.
- Failure to install, operate, and maintain the equipment in accordance with this manual will adversely affect safety, performance, component life, and warranty coverage.
- To reduce the risk of electric shock, do not touch the control switch or mode switch with damp hands.
- **Before Performing Maintenance/Service:** Move the control switch to the "OFF" position and turn off the power supply. Lockout/Tagout to prevent the power supply from being turned back on inadvertently. Control switch in "OFF" position does not de-energize all loads.
- **CHOKING HAZARD:** Ensure all components, fasteners, and thumbscrews are securely in place after any maintenance is done to the appliance. Make sure that none have fallen into the dispenser unit/ice storage bin.
- After service, make sure that there are no wires pinched between the panels and appliance. Make sure you do not damage or pinch the water supply line or drain line.

A. User Maintenance Schedule

The user maintenance schedule below is a guideline. More frequent maintenance may be required depending on water quality, the appliance's environment, and local sanitation regulations.

Maintenance Schedule		
Frequency	Area	Task
Daily	Scoop	Clean the ice scoop using a neutral cleaner. Rinse thoroughly after cleaning.
Bi-Weekly	Air Filters	Inspect. Wash with warm water and neutral cleaner if dirty.
Monthly	Appliance Exterior	Wipe down with a clean, soft cloth. Use a damp cloth containing a neutral cleaner to wipe off oil or dirt build up. Clean any chlorine staining (rust colored spots) using a non-abrasive cleanser.

B. Service Maintenance Schedule

The service maintenance schedule below is a guideline; service maintenance items are to be performed by qualified service technicians only. More frequent maintenance may be required depending on water quality, the appliance's environment, and local sanitation regulations.

Maintenance Schedule		
Frequency	Area	Task
Monthly	External Water Filters	Check for proper pressure and change if necessary.
	Bin Control Lens	Wipe down the bin control lens, (located on the bottom of the icemaker) with a neutral cleaner. Rinse thoroughly after cleaning.
	Underside of Icemaker and Top Kits; Bin Door and Snout	Wipe down with a clean, soft cloth. Use a damp cloth containing a neutral cleaner to wipe off oil or dirt build up. Clean any chlorine staining (rust colored spots) using a non-abrasive cleanser.
Yearly	Icemaker and Dispenser Unit/Ice Storage Bin	Clean and sanitize per the cleaning and sanitizing instructions provided in this manual.
	Inlet Water Valve, Cleaning Valve, and Drain Valve	Close the water supply line shut-off valve and drain the water system. Clean the inlet water valve and cleaning water valve screens and clean and inspect the drain valve.
	Condenser	Inspect. Clean if necessary by using a brush or vacuum cleaner. More frequent cleaning may be required depending on location.
	Water Hoses	Inspect the water hoses and clean/replace if necessary.
	Appliance	Inspect for oil spots, loose components, fasteners, and wires.

C. Cleaning and Sanitizing Instructions

The icemaker must be cleaned and sanitized at least once a year. More frequent cleaning and sanitizing may be required in some water conditions.

⚠ WARNING

- To prevent injury to individuals and damage to the icemaker, do not use ammonia type cleaners.
- Carefully follow any instructions provided with the bottles of cleaning and sanitizing solution.
- Always wear liquid-proof gloves and goggles to prevent the cleaning and sanitizing solutions from coming into contact with skin or eyes.
- Do not leave the icemaker unattended when panels are off.

NOTICE

- To prevent damage to the water pump, do not leave the control switch in the "PUMP" position for extended periods when the water tank is empty.
- Terminating a cleaning/sanitizing cycle early:
 - a) Terminating a cleaning cycle at step 4 or earlier in "Cleaning" below, returns the icemaker to the normal icemaking mode. The control board "CLEAN" LED turns off.
 - b) Terminating a cleaning cycle at step 5 or later in "Cleaning" below, sends the icemaker into a 3-rinse cycle (approx. 18 min.). The control board "CLEAN" LED remains on throughout the 3-rinse cycles. After the 3rd rinse cycle, icemaker goes into the normal icemaking mode and the control board "CLEAN" LED turns off.

Preparation

- 1) Remove the front panel, then move the control switch to the "OFF" position. Make sure the mode switch is in the "ICE" position. After 3 minutes, move the control switch to the "ON" position and replace the front panel.
- 2) Allow the appliance to run until the compressor energizes. Once the compressor energizes, allow the appliance to run for an additional 3 minutes, then remove the front panel and control box cover. Move the control switch to the "OFF" position.
- 3) Remove all ice from the dispenser unit/ice storage bin. **WARNING! If on a dispenser unit, turn off the dispenser unit power supply after dispensing the ice.**

Cleaning

- 4) Move the mode switch to the "CLEAN" position, then move the control switch to the "ON" position (1 short beep occurs, then 3 seconds later 1 long beep occurs). Replace the front panel. The water tank drains and then fills.
- 5) When the control board starts beeping (2 beep sequence), remove the front panel. Move the control switch to the "OFF" position.
- 6) Remove the front insulation panel, then pour Hoshizaki "Scale Away" into the water tank. See the table below for amount. Replace the front insulation panel.

Model	Scale Away
KM-322_522_622MAK	13 fl. oz. (384 ml)(26 tbs)
KM-330_530_730MAK	17 fl. oz. (503 ml)(34 tbs)
KM-930MAK2, KM-1130MAK2	20 fl. oz. (591 ml)(40 tbs)

- 7) Move the control switch to the "ON" position (1 short beep occurs, then 3 seconds later 1 long beep occurs). Replace the front panel. To avoid excessive foaming in the water tank, there is a 1 minute delay before circulation begins. After approximately 30 minutes of circulation, the icemaker performs 3 rinse cycles.
- 8) When the control board starts beeping (5 beep sequence), remove the front panel. Move the control switch to the "OFF" position.
- 9) In bad or severe water conditions, turn off the power supply, then remove, clean (cleaning solution = 5 oz. Hoshizaki "Scale Away" per gallon of warm water), rinse, and replace the cube guide, float switch, water supply tubes, spray tubes, and spray guides; turn on the power supply when complete. Otherwise, continue to step 10.
- 10) Wipe down the bin control lens, (located on the bottom of the icemaker) with a neutral cleaner. Rinse thoroughly after cleaning. Note: If the bottom of the icemaker is not accessible in your application, remove the top and right side panels, then remove the thumbscrew securing the bin control housing and remove the bin control housing from the base. After cleaning and rinsing the bin control lens, replace the bin control housing in its correct position and secure it with the thumbscrew. Next, replace the right side and top panels in their correct positions.

Sanitizing

- 11) Confirm the mode switch is in the "CLEAN" position, then move the control switch to the "ON" position (1 short beep occurs, then 3 seconds later 1 long beep occurs). Replace the front panel. The water tank drains and then fills.
- 12) When the control board starts beeping (2 beep sequence), remove the front panel. Move the control switch to the "OFF" position.
- 13) Remove the front insulation panel, then pour 7.5% sodium hypochlorite solution (chlorine bleach) into the water tank. See the table below for amount. Replace the front insulation panel. **IMPORTANT! Use regular bleach with no additives. Using a bleach with additives causes excessive foaming during sanitizing, reducing the effectiveness of sanitizing.**

Model	Scale Away
KM-322_522_622MAK	0.8 fl. oz. (24 ml)(1.6 tbs)
KM-330_530_730MAK	1.0 fl. oz. (31 ml)(2 tbs)
KM-930MAK2, KM-1130MAK2	1.3 fl. oz. (38 ml)(2.5 tbs)

- 14) Move the control switch to the "ON" position (1 short beep occurs, then 3 seconds later 1 long beep occurs). Replace the front panel. To avoid excessive foaming in the water tank, there is a 1 minute delay before circulation begins. After approximately 30 minutes of circulation, the icemaker performs 3 rinse cycles.
- 15) When the control board starts beeping (5 beep sequence), remove the front panel. Move the control switch to the "OFF" position.
- 16) Clean the dispenser unit/ice storage bin liner using a neutral cleaner. Rinse thoroughly after cleaning.
- 17) Move the mode switch to the "ICE" position, then move the control switch to the "ON" position. Note: If on a dispenser unit, turn on the dispenser unit power supply.
- 18) Replace all panels and covers in their correct positions.

V. Preparing the Appliance for Periods of Non-Use

⚠ WARNING

Only qualified service technicians should service this appliance.

NOTICE

- | |
|--|
| <ul style="list-style-type: none">• During extended periods of non-use, extended absences, or in sub-freezing temperatures, follow the instructions below to reduce the risk of costly water damage.• When the appliance is not used for two or three days under normal conditions, it is sufficient to move the control switch to the "OFF" position.• To prevent damage to the water pump, do not leave the control switch in the "PUMP" position for extended periods when the water tank is empty. |
|--|

When the appliance is not used for two or three days under normal conditions, it is sufficient to move the control switch to the "OFF" position. When storing the appliance for an extended time or in sub-freezing temperatures, follow the instructions below.

1. Remove the water from the icemaker water supply line:

- 1) Remove the front panel. Move the control switch to the "OFF" position, then turn off the power supply.
- 2) Close the icemaker water supply line shut-off valve, then open the icemaker water supply line drain valve.
- 3) Allow the line to drain by gravity.
- 4) Attach a compressed air or carbon dioxide supply to the icemaker water supply line drain valve.
- 5) Move the control switch to the "ICE" position.
- 6) Replace the front panel in its correct position, then turn on the power supply.
- 7) Blow the icemaker water supply line out using the compressed air or carbon dioxide supply.
- 8) Close the icemaker water supply line drain valve.

2. Drain the water tank:

1) Remove the front panel. Move the control switch to the "OFF" position, then turn off the power supply.

2a)(1) For **KM-322_522_622MAK** - Remove the front insulation panel, then disconnect the water tank pump tubing located behind the base cover. See Fig. 17. Allow the water tank to drain.

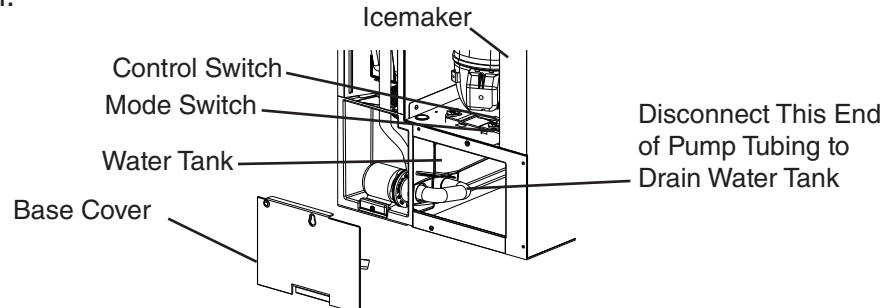

Fig. 17

2a)(2) After the water tank has drained, replace the water tank pump tubing and base cover back in their correct positions. Continue to step 3 below.

2b)(1) For **KM-330_530_730MAK** - Remove the front insulation panel, then remove the water tank drain plug located in the bottom of the water tank. See Fig. 18. Allow the water tank to drain.

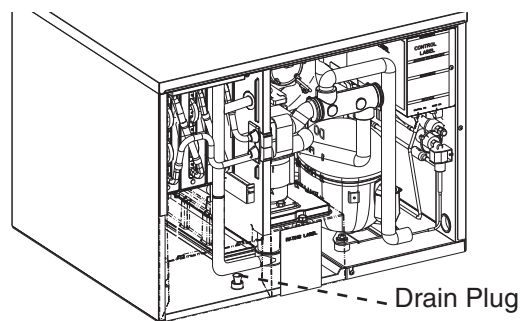

Fig. 18

2b)(2) After the water tank has drained, replace the drain plug back in its correct position. Continue to step 3 below.

2c)(1) For **KM-930MAK2** and **KM-1130MAK2** - Remove the splash guard and cube guide B. See Fig. 20.

Next, slide cube guide A to the right and pull forward to remove cube guide A.

NOTICE! The rear portion of cube guide A is placed outside and underneath the rear evaporator bracket. Lift the front of cube guide A and push down and pull cube guide A to slide it out from under the rear evaporator bracket.

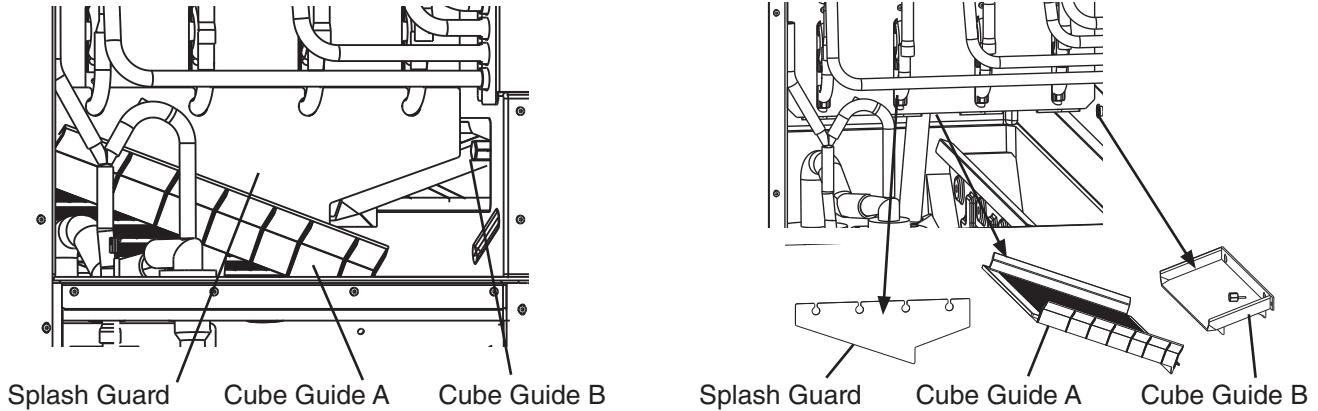

Fig. 20

2c)(2) Remove the rubber cap and sleeve covering the overflow pipe. See Fig. 21.

Unscrew the overflow pipe.

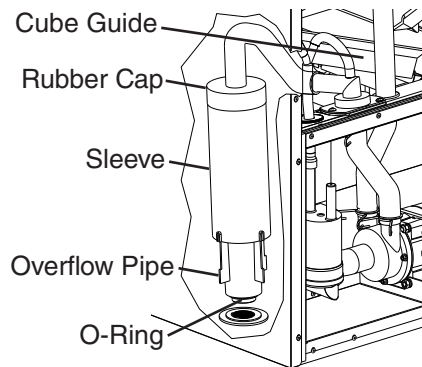

Fig. 21

2c)(3) After the water tank has drained, reconnect the overflow pipe. Replace the rubber cap and sleeve in their correct positions. Continue to step 3 below. **NOTICE!** Make sure the O-ring is attached to the bottom of the overflow pipe and be careful not to cross thread the overflow pipe.

2c)(4) Replace cube guide A in its correct position. **NOTICE!** The rear portion of cube guide A must be placed back to the outside of the evaporator plastic bracket to allow proper positioning of cube guide A.

3) Replace the front insulation panel and front panel in their correct positions.

4) Remove all ice from the dispenser unit/ice storage bin. Clean the dispenser unit/ice storage bin liner using a neutral cleaner. Rinse thoroughly after cleaning.

VI. Decommissioning and Disposal



R-290 Class A3 Flammable Refrigerant Used*

⚠ DANGER

Risk of Fire or Explosion. Flammable Refrigerant Used.*

- Only qualified service technicians should install and service the appliance.
- Follow handling instructions carefully in compliance with national regulations.
- Dispose of properly in accordance with federal or local regulations.
- Do not puncture refrigerant tubing. Risk of fire or explosion due to puncture of refrigerant tubing; follow handling instructions carefully.
- Be sure to follow the full Decommissioning and Disposal information located in the Service Manual for this model. The Service Manual is available at: www.hoshizakiamerica.com.

Risque D'Incendie ou D'Explosion. Fluide Frigorigène Inflammable Utilisé.*

- Seuls des techniciens de service qualifiés doivent installer et entretenir l'appareil.
- Suivre attentivement les instructions de manutention conformément aux règlements nationaux.
- Mettre au rebut conformément aux règlements fédéraux ou locaux.
- Ne pas perforer la conduite de fluide frigorigène. Risque d'incendie ou d'explosion en cas de perforation d'une canalisation de fluide frigorigène; suivez attentivement les instructions de manutention.
- Veiller à respecter l'ensemble des informations relatives à la mise hors service et à la mise au rebut figurant dans le manuel d'entretien de ce modèle. Le manuel d'entretien est disponible à l'adresse suivante: www.hoshizakiamerica.com.

*This statement applies to models utilizing R-290 refrigerant. See the nameplate or the Electrical and Refrigerant Data section of this manual for the refrigerant type in your model.

*Cette déclaration s'applique aux modèles utilisant le réfrigérant R-290. Consultez la plaque signalétique ou la section Données électriques et de réfrigérant de ce manuel pour connaître le type de réfrigérant de votre modèle.

HOSHIZAKI AMERICA, INC.

618 Hwy. 74 South, Peachtree City, GA 30269 USA (P) 770.487.2331 (F) 770.487.3360 hoshizakiamerica.com 1A8309-012