



SPEC SHEET

Commercial 40 lb Electric Deep Fryer 240V, 3 Phase

Model: KM-FDF40-EE

FEATURES

- **High-Capacity 40 lb. Fry Tank:** Large oil capacity supports higher-volume frying with fewer refills, helping maintain consistent output during peak service.
- **Powerful 14,000W Heating System:** Two 7,000W stainless-steel heating elements deliver fast heat-up and strong temperature recovery for steady frying performance.
- **Hardwired 240V 3-Phase Convertible Power:** Designed for commercial electrical systems and can be converted to single phase when needed for added installation flexibility.
- **Precision Digital Temperature Control:** Easy-to-use digital controls with a real-time display help maintain consistent cooking results from 200°F–400°F.
- **Safety Shutoff Protection:** Built-in safety system automatically shuts the unit down if overheating occurs to help protect the equipment and reduce risk.
- **Lift-Up Locking Heating Elements:** Hinged elements lift and lock upright to provide full fry tank access for faster cleaning and routine maintenance.
- **Dual Fry Baskets Included:** Comes with two heavy-duty baskets to fry multiple items at once while supporting smoother workflow and safer handling.
- **Front-Mounted Control Panel Indicators:** Clear power and heating lights allow staff to quickly confirm operating status and temperature readiness.



CLOSE UP IMAGES



Technical Specs

Dimensions & Weight

Length	15.51 in.
Width	30.07 in.
Height	44.66 in.
Weight	119 lbs.
Interior Depth	16.45 in.
Interior Width	14.02 in.
Interior Height	6.97 in.

Electric & Certifications

Voltage	240
Wattage	14000
Hertz	60
Amps	36
Phase	3
Plug Type	NEMA 5-15P
Power Cord Included	No
Energy Consumption	40880 kWh/year
Electrical Installation Type	Hardwire
Certifications	ETL Listed for Safety and Sanitation

Capacity

Oil Capacity	40 lbs.
Number of Baskets	2

Features & Materials

Commercial Residential	Commercial
Installation Type	Freestanding
Diameter of Water Line Connection	0.5
Diameter of Drain Line Connection	1.5 In.
Backsplash Size	15.51" x 4.88" x 10.36"
Number of Elements	2
Heating Element Wattage	7000 kW
Temperature Range	200–400°F
Temperature Display	Digital
Control Type	Digital
Control Location	Front
Number of Temperature Zones	1
Number of Temperature Cooking Controls	2
Basket Lifts	Yes
Hot Surface Indicator Lights	Yes
Exterior Material	Galvanized Steel
Gauge of Stainless Steel	19
Interior Material	Stainless Steel 439
Basket Material	Iron with Nickel Coating
Color Finish	Stainless Steel
Automatic Filtration	No
Included	2 Baskets, 1 Extension Drain Tube, 1 Rack
Number of Legs	4
Legs Material	Stainless-Steel 201
Legs Adjustable	Yes, 2.3 In.
Casters	No
Lift Element	Yes

Plan View

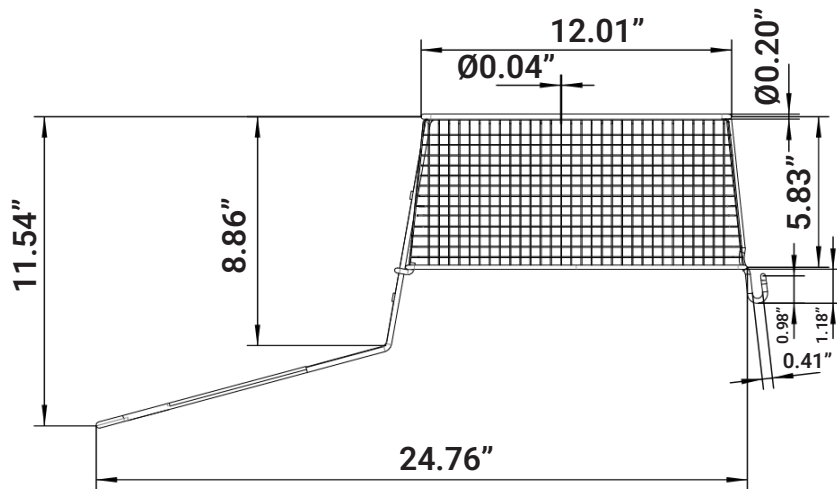
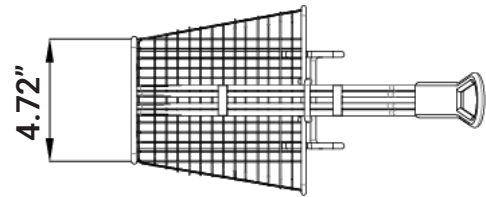
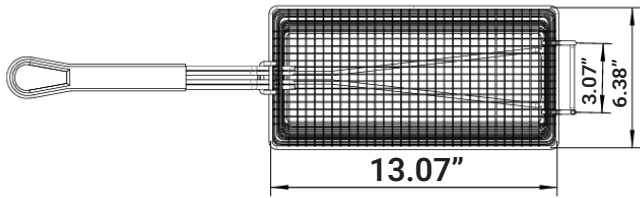
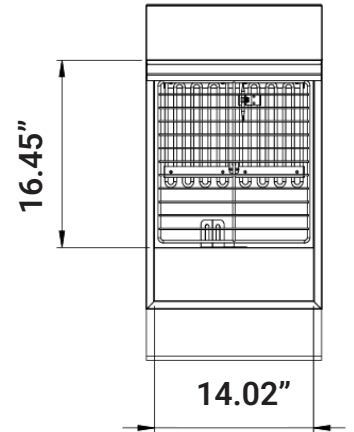
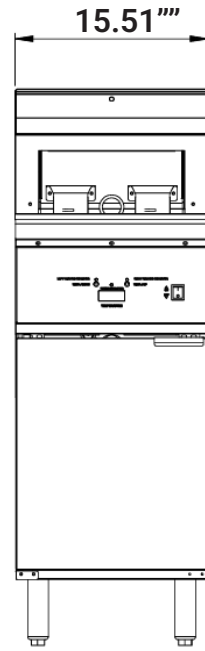
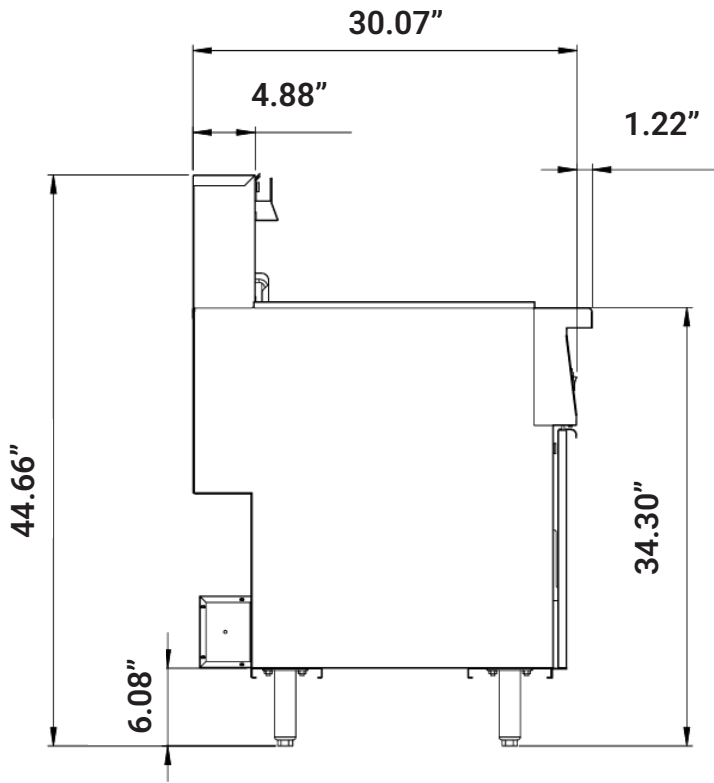

718-576-6342
info@koolmore.com