



USER MANUAL

Microwave Oven

KoolMore Stainless Steel Over the Range Microwave Oven With Sensor Cooking

Model: KM-MOTSC-16BSS

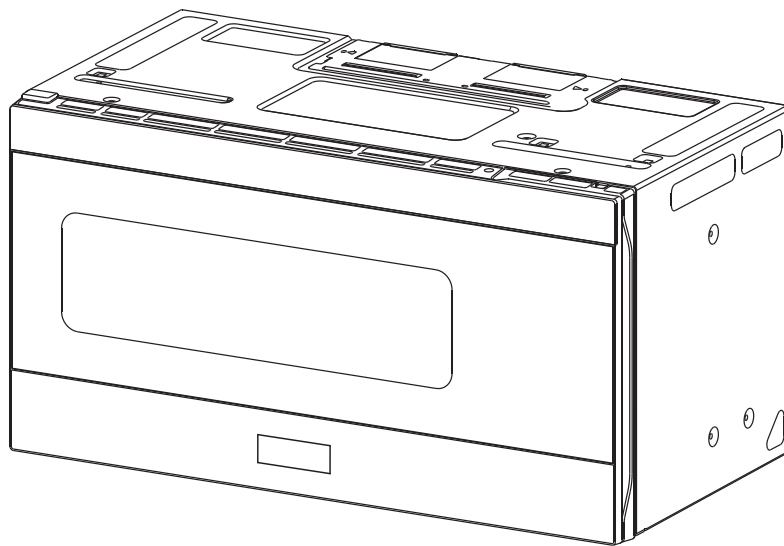

Before using, please read the operating instructions carefully to ensure proper application and achieve satisfactory results.

For any service-related issues, please contact us:



718-576-6342



support@koolmore.com

***Stay informed with the latest information
for your KoolMore Appliance.***

**If you need any assistance or have questions, our customer
support team is here to help.**

SAFETY

- SAFETY INFORMATION

- For your safety, the information in this manual must be followed to minimize the risk of fire or explosion or to prevent property damage, personal injury, or loss of life.

- **Precautions to avoid possible exposure to excessive microwave energy:**

- Do not attempt to operate this microwave with the door open because this can result in harmful exposure to microwave energy. It is important not to defeat or tamper with the safety interlocks.
- Do not place any object between the microwave front face and the door or allow soil or cleaner residue to accumulate on sealing surfaces.
- Do not operate the microwave if it is damaged. It is particularly important that the microwave door closes properly and that there is no damage to the:
 - (a) door (bent)
 - (b) hinges and latches (broken or loosened)
 - (c) door seals and sealing surfaces
- 4. The microwave should not be adjusted or repaired by anyone except properly qualified service personnel.

- **IMPORTANT SAFETY INSTRUCTIONS**

- **Warning**

- WARNING indicates a potentially hazardous situation which, if not avoided, could result in death or serious injury.

- **Caution**

- CAUTION indicates a potentially hazardous situation which, if not avoided, may result in minor or moderate injury.

- **READ ALL INFORMATION BEFORE USING**

- **Warning**

- To reduce the risk of fire, burns, electric shock, injury to persons, or exposure to excessive microwave energy when using your appliance, follow the basic precautions included in the following sections.

- Read all instructions before using the appliance.

- Read and follow the specific "Precautions to avoid possible exposure to excessive microwave energy:" on page 3.

- This appliance must be grounded. Connect only to a properly grounded outlet. See "Grounding instructions" on page 4.

- Install or locate this appliance only in accordance with the provided installation instructions.
- Some products such as whole eggs and sealed containers — for example, closed glass jars — are able to explode and should not be heated in this microwave oven.
- Use this appliance only for its intended use as described in this manual. Do not use corrosive chemicals or vapors in this appliance. This type of microwave oven is specifically designed to heat, cook, or dry food. It is not designed for industrial or laboratory use.
- As with any appliance, close supervision is necessary when used by children.
- Do not operate this appliance if it has a damaged cord or plug, if it is not working properly, or if it has been damaged or dropped.
- This appliance should be serviced only by qualified service personnel. Contact nearest Authorized Servicer for examination, repair, or adjustment.
- Do not cover or block any openings on the appliance.
- Do not store or use this appliance outdoors. Do not use this product near water—for example, near a kitchen sink, in a wet basement, or near a swimming pool, or similar locations.
- Do not immerse the cord or plug in water.
- Keep the cord away from heated surfaces.
- Do not let the cord hang over the edge of the table or counter.
- See door surface cleaning instructions on page 16.
- To reduce the risk of fire in the microwave oven cavity:
- Do not overcook food. Carefully attend to the appliance when paper, plastic, or other combustible materials are placed inside the microwave oven or plastic bags cooking.
- Remove wire twist-ties from paper or plastic facsimile before placing the bag in the microwave oven.
- If materials inside the microwave oven ignite, keep the microwave oven door closed, turn the microwave oven off, and disconnect the power cord or shut off power at the fuse or circuit breaker panel.
- Do not use the cavity for storage purposes. Do not leave paper products, cooking utensils, or food in the cavity when not in use.
- Liquids, such as water, coffee, or tea are able to be overheated beyond the boiling point without appearing to be boiling. Visible bubbling or boiling when the container is removed from the microwave oven is not always present. **THIS COULD RESULT IN VERY HOT LIQUIDS SUDDENLY BOILING OVER WHEN A SPOON OR OTHER UTENSIL IS INSERTED INTO THE LIQUID.**

To reduce the risk of injury to persons:

- Do not overheat the liquid.
- Stir the liquid both before and halfway through heating it.
- Do not use straight-sided containers with narrow necks. Use a wide-mouthed container.
- After heating, allow the container to stand in the microwave oven for at least for 20 seconds before removing the container.
- Use extreme care when inserting a spoon or other utensil into the container.
- Clean the ventilation openings and grease filters frequently. Grease should not be allowed to accumulate on ventilation openings, louver, or grease filters.
- Use care when cleaning the louver and the grease filters. Corrosive cleaning agents, such as lye-based oven cleaners, may damage the louver and the grease filters.
- When flaming food under the hood, turn the fan on.
- This appliance is suitable for use above both gas and electric cooking equipment 36" wide or less.

This device complies with part 18 of the FCC Rules.

SETUP

SAVE THESE INSTRUCTIONS

Unpacking and examining your microwave

Open the bottom of the carton, bend the carton flaps back, and tilt the microwave oven over to rest on the plastic foam pad. Lift the carton off the microwave oven and remove all packing materials, including the User Guide, Installation Guide, templates (2), charcoal filter, and turntable (with ring). **SAVE THE CARTON AS IT MAY MAKE INSTALLATION EASIER.**

Remove the feature sticker from the outside of the door, if there is one.

DO NOT REMOVE THE WAVEGUIDE COVER.

Read and **SAVE** the User Guide and Installation Guide.

Check the microwave oven for any damage, such as misaligned or bent door, damaged door seals and sealing surfaces, broken or loose door hinges and latches, and dents inside the cavity or on the door. If there is any damage, do not operate the microwave oven and contact your dealer or repair center. See Installation Instructions for more details.

Grounding instructions

This appliance must be grounded. This microwave oven is equipped with a cord having a grounding wire with a grounding plug. It must be plugged into a wall receptacle that is properly installed and grounded in accordance with the National Electrical Code and local codes and ordinances. In the event of an electrical short circuit, grounding reduces the risk of electric shock by providing an escape wire for the electric current.

Warning: Improper use of the grounding plug can result in a risk of electric shock.

Electrical requirements

Check the Installation Instructions for proper location for the power supply.

The electrical requirements are a 120 volt AC, 60 Hz, 15 amp. or more protected electrical supply. It is recommended that a separate circuit serving only the microwave oven be provided.

The microwave oven is equipped with a 3-prong grounding plug. It must be plugged into a wall receptacle that is properly installed and grounded. **DO NOT UNDER ANY CIRCUMSTANCES CUT OR REMOVE THE GROUNDING PIN FROM THE PLUG. DO NOT USE AN EXTENSION CORD.**

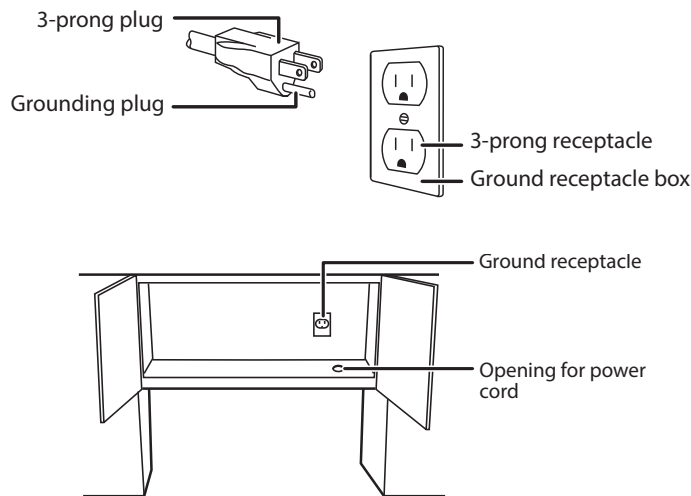

If the power supply cord is too short, have a qualified electrician or serviceman install an outlet near the appliance.

The power supply cord and plug must be connected to a separate 120 Volt AC, 60 Hz, 15 Amp, or more branch circuit, single grounded receptacle. The receptacle should be located inside the cabinet directly above the microwave oven mounting location as shown above.

Notes

If you have any questions about the grounding or electrical instructions, consult a qualified electrician or service person. Does not accept any liability for damage to the microwave oven or personal injury resulting from failure to observe the correct electrical connection procedures.

ABOUT YOUR MICROWAVE OVEN

- Read this User Guide and always save it for reference.
- A good microwave cookbook is a valuable asset. Check it for microwave cooking principles, techniques, hints, and recipes.
- NEVER use the microwave oven without the turntable and support nor turn the turntable over so that a large dish could be placed on the microwave oven. The turntable will not turn both clockwise and counterclockwise.
- ALWAYS have food in the microwave oven when it is on to absorb the microwave energy.
- When using the microwave oven at power levels below 100%, you may hear the magnetron cycling on and off. It is normal for the exterior of the microwave oven to be warm to the touch when cooking or reheating.
- Condensation is a normal part of microwave cooking. Round and smooth outside of food will not cause as much amount of moisture that condenses in the microwave oven. Generally covered food dishes will cause a condensation wave uncovered. Ventilation openings must not be blocked.
- The microwave oven is not for commercial use. It should not be used to dry clothes, newspapers, or other materials. Your microwave oven is rated at 800 watts by using the IEC Test Procedure. In using recipes or package directions, check food a minute or two before the minimum time and add time accordingly.

OPERATION

MICROWAVE COOKING

- Arrange food carefully. Place thickest areas towards outside of the dish.
- Watch the cooking time. Cook for the shortest amount of time indicated and add more as needed. Food severely overcooked can smoke or ignite.
- Cover foods while cooking. Check the recipe or cookbook for suggestions, such as paper towels, wax paper, microwave plastic wrap, or a lid. Covers prevent spattering and help foods to cook evenly.
- Shield with small flat pieces of aluminum foil any thin areas of meat or poultry to prevent overcooking before dense, thick areas are cooked thoroughly.
- Stir foods from outside to center of dish once or twice during cooking, if possible.
- Turn foods over once during microwaving to speed cooking of such foods as chicken and hamburgers. Large items like roasts must be turned over at least once.
- Rearrange foods such as meatballs halfway through cooking both from top to bottom and from the center of the dish to the outside.
- Add standing time. Remove the food from the microwave oven and stir, if possible. Cover for the standing time which allows the food to finish cooking without overcooking.
- Check for doneness. Look for signs indicating that cooking temperatures have been reached.

Doneness signs include:

- Food steams throughout, not just at edge.
- Center bottom of dish is very hot to the touch.
- Poultry thigh joints move easily.
- Meat and poultry show no pinkness.
- Fish is opaque and flakes easily with a fork.
- Cookware and cooking materials

Warning: Personal Injury Hazard

Tightly-closed containers could explode. Closed containers should be opened and plastic pouches should be pierced before cooking.

Cookware and other materials must fit on the turntable. Always use oven mitts or pot holders because cookware may become hot.

Refer to “Materials you can use” on page 7 and “Materials to be avoided” on page 7 as a guide, then test before using.

Cookware and Materials Test:

1. Fill a microwave-safe container with 1 cup (250 ml) of cold water, along with the cookware or materials in question.
2. Cook on maximum power for one minute. Do not exceed one minute cooking time.
3. Carefully feel the cookware or material. If the empty cookware or material is warm, do not use it for microwave cooking.

Materials you can use

MATERIAL	REMARKS
Browning dish	Follow the manufacturer's instructions. The bottom of the browning dish must be at least 3/16-in. (5mm) above the turntable. Incorrect usage may cause the turntable to break.
Dinnerware	Use microwave-safe only. Follow the manufacturer's instructions. Do not use cracked or chipped dishes.
Glass jars	Always remove the lid. Use only to heat food until just warm. Most glass jars are not heat resistant and may break.
Glassware	Use heat-resistant oven glassware only. Make sure there is no metallic trim. Do not use cracked or chipped dishes.
Oven cooking bags	Follow the manufacturer's instructions. Do not close with a metal tie. Make slits to allow steam to escape.
Paper plates and cups	Use for short-term cooking/warming only. Do not leave the oven unattended while cooking.
Paper towels	Use to cover food for reheating and absorbing fat. Use with supervision for short-term cooking only.
Parchment paper	Use as a cover to prevent splattering or a wrap for steaming.
Plastic	Use only if labeled "Microwave Safe." Follow the manufacturer's instructions. Some plastic containers soften as the food inside gets hot. "Boiling bags" and tightly closed plastic bags should be slit, pierced, or vented, as indicated on the package.
Plastic wrap	Use microwave-safe only. Use to cover food during cooking to retain moisture. Do not allow plastic wrap to touch food.
Thermometers	Use microwave-safe only (such as meat and candy thermometers).
Wax paper	Use as a cover to prevent splattering and retain moisture.

Materials to be avoided

MATERIAL	REMARKS
Aluminum tray	May cause arcing. Use a microwave-safe dish instead.
Food carton with metal handle	May cause arcing. Use a microwave-safe dish instead.
Metal or metal trimmed utensils	Metal shields the food from microwave energy. The metal trim may cause arcing.
Metal twist ties	May cause arcing and could cause a fire in the oven.
Paper bags	May cause a fire in the oven.
Plastic foam	Plastic foam may melt or contaminate the liquid inside when exposed to high temperature.
Wood	Wood will dry out when used in the microwave oven and may split or crack.

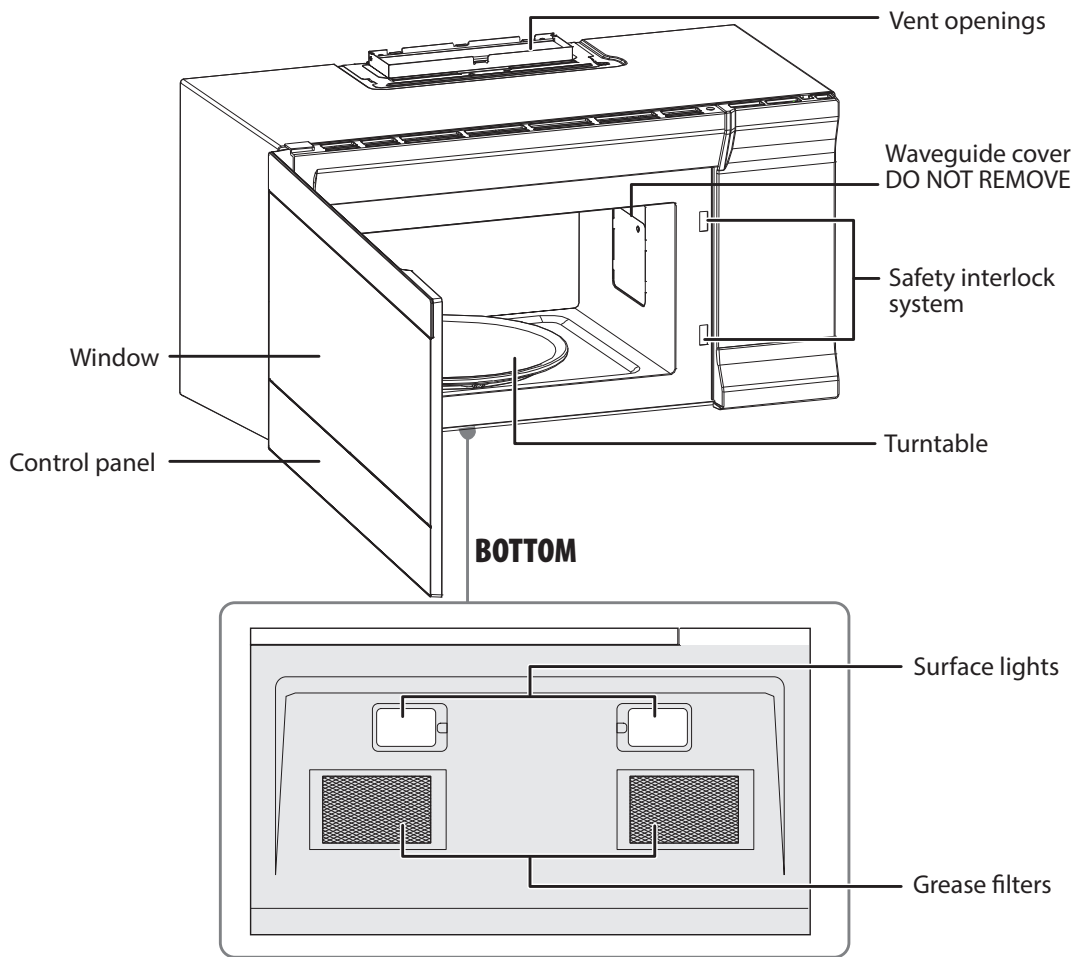

Features

- Sensor cooking
- 10 variable power levels
- Add 30 seconds and express cooking
- 1000W of power
- Exhaust fan with two speeds
- Task lighting
- Child lock
- Turntable
- Hidden vent

Package contents

- 1.6 cu. ft. over-the-range microwave oven
- Turntable (with ring)
- Installation hardware
- Grease filters (2)
- *Installation Guide*
- *User Guide*

Microwave oven

Control panel

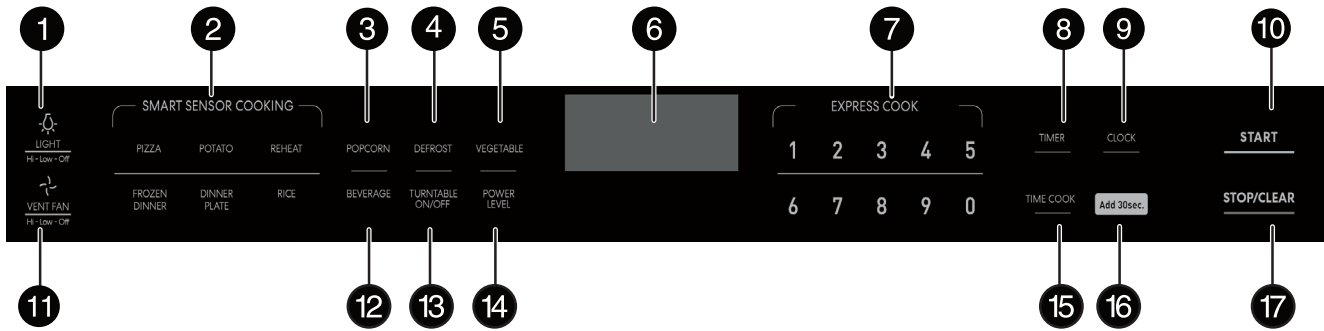

#	ITEM	DESCRIPTION
1	Light	Press to turn on/off the light underneath your microwave. See "Using the light" on page 16.
2	SENSOR COOKING	Detects the humidity released by your cooking food and adjusts the cooking time based on the type and amount of food cooking.
3	Popcorn	Press to cook popcorn. See "Popcorn" on page 16.
4	Defrost	Press to defrost frozen food. See "Defrosting in your microwave" on page 13.
5	Vegetable	Press to cook vegetables. See "Vegetable" on page 14.
6	Display	In standby mode, displays the time. In cooking mode, displays cooking time, weight, and other information.
7	Number pad	Press to enter cook time, defrost time, clock time, and other information.
8	Timer	Press this button, then enter the time you want to count down. See "Using the kitchen timer" on page 12.
9	Clock	Press to set or check the clock. See "Setting the clock]" on page 13
10	START	In standby mode, press this button to begin cooking.
11	Vent Fan	Press to turn on/off your vent fan and remove odors from cooking. See "Using the vent fan" on page 16.
12	Beverage	Press to heat a beverage. See "Beverage" on page 16.
13	Turntable on/off	Press to turn your turntable on or off. See "Using the turntable" on page 16.
14	Power Level	Press to change your microwave's power level (1-10). See "Cooking in your microwave" on page 12.
15	Time Cook	Press to enter a cooking time.
16	Add 30 sec.	While cooking, press this button to add 30 seconds to your cooking time.
17	STOP/CLEAR	Press to stop the cooking process. Press again to cancel the cooking operation.

Setting up your microwave oven

See the *Installation Guide* (included in your box) to install and set up your microwave. You can also find the *Installation Guide* online:

- 1 Go to .
- 2 Use the search bar to find your model number ().
- 3 Select **Support & Downloads**.
- 4 Next to *Installation Guide*, select the language you want.

Installing the turntable

Notes

- *Never place the glass tray upside down. The glass tray should never be restricted.*
- *Always place all food and containers of food on the glass tray during cooking.*
- *Both the glass tray and turntable ring must always be used for cooking.*
- *If the glass tray or turntable ring cracks or breaks, contact your nearest authorized service center.*

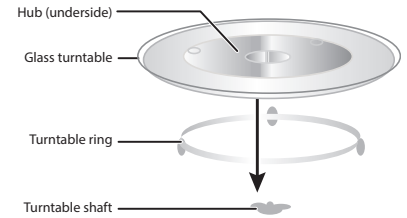

1. Place the turntable ring in the round depression in the bottom of the microwave oven so that it turns freely.
2. Place the glass turntable (flat side up) on the turntable ring so that the hub engages the turntable shaft in the bottom of the oven. The glass turntable should not turn freely when it is correctly installed.

USING YOUR MICROWAVE

Tips for the best results

Storage temperature

Foods taken from the freezer or refrigerator take longer to cook than the same foods would at room temperature.

Size

Small pieces of food cook faster than large ones. Pieces similar in size and shape will cook more evenly when cooked together. For more even results, reduce the power levels when cooking large pieces of food.

Natural moisture

Very moist foods cook more evenly because microwave energy heats water molecules very efficiently.

Stirring

Stir foods such as casseroles and vegetables from the outside to the center to distribute the heat more evenly. This will allow the food to cook faster. Constant stirring is not necessary.

Turn over items

Turn over foods such as pork chops, roasts, or whole cauliflower halfway through the cook time. This will help to expose all sides equally to microwave energy.

Food placement

Place delicate areas of food items, such as asparagus tips, toward the center of the turntable tray.

Food arrangement

Arrange unevenly shaped foods, such as chicken pieces or salmon, with the thicker or meatier parts toward the outside of the turntable tray.

Let the food stand

After removing the food from the microwave, cover the food with foil or a casserole lid and let it stand to finish cooking. This will help the food finish in the center and avoids overcooking the outer edges. The length of stand time depends on the density and surface area of the food items.

Wrapping in paper towels or waxed paper

Sandwiches and many other food types containing pre baked bread should be wrapped prior to placing in the microwave to help prevent the food items from drying out while heating.

Cooking in your microwave

1. Press Time Cook, then use the number pad to enter the cooking time that you want.

Note: For example, to enter 3 minutes and 15 seconds, press 3, 1, and then 5.

2. (Optional) Press Power Level, then enter the power level that you want (1-10).

*Note: By default, your microwave cooks at 100% power.
Press Power Level while cooking to check the power level.*

POWER LEVEL	OUTPUT	RECOMMENDED WHEN...
10	100%	<ul style="list-style-type: none">• Boiling water.• Cooking ground beef.• Making candy.• Cooking fresh fruits and vegetables.• Cooking fish and poultry.• Preheating browning dish.• Reheating beverages.• Cooking bacon slices.
9	90%	<ul style="list-style-type: none">• Reheating meat slices quickly.• Sautéing onions, celery, and green peppers.
8	80%	<ul style="list-style-type: none">• All reheating.• Cooking scrambled eggs.
7	70%	<ul style="list-style-type: none">• Cooking breads and cereal products.• Cooking cheese dishes and veal.• Cooking cakes, muffins, brownies and cupcakes.
6	60%	<ul style="list-style-type: none">• Cooking pasta.
5	50%	<ul style="list-style-type: none">• Cooking meats and whole poultry.• Cooking custard.• Cooking spare ribs, rib roast, and sirloin roast.
4	40%	<ul style="list-style-type: none">• Cooking less tender cuts of meat.• Reheating frozen packaged foods.
3	30%	<ul style="list-style-type: none">• Thawing meat, poultry, and seafood.• Cooking small quantities of food.• Finish cooking casseroles, stew, and some sauces.
2	20%	<ul style="list-style-type: none">• Softening butter and cream cheese.• Heating small amounts of food.
1	10%	<ul style="list-style-type: none">• Softening ice cream.• Raising yeast dough.

3 Press **Start** to begin heating.

Cooking with multiple cooking stages

For best results, some microwave recipes call for different power levels or different lengths of time for cooking. Your microwave may be set to change from one stage to another automatically (two stages maximum).

1. Press Time Cook, then use the number pad to enter the cooking time that you want for the first stage.

Note: For example, to enter 3 minutes and 15 seconds, press 3, 1, and then 5.

2. Press Power Level, then enter the power level that you want (1-10) for the first stage. The power level (PL) is shown on the display.

3. Press Time Cook, then use the number pad to enter the cooking time for the second stage.

4. Press Power Level, then enter the power level that you want (1-10) for the second stage. The power level (PL) is shown on the display.

5. Press Start to begin heating. When the microwave is done, it beeps and shows "END" on the display.

Setting the clock

Press Clock to check the time while cooking.

1. Press Clock.
2. Use the number pad to enter the current time (1:00–12:59), then press Start to confirm the setting.

Using the Timer

You can use the timer while the microwave is cooking.

1. In standby mode, press Timer.
2. Use the number pad to enter the time, then press Start. When the time reaches 0, your microwave beeps.

Cooking quickly

- Press a number on the number pad to instantly start cooking. For example, to cook for two minutes, press 2.
- From standby, press Add 30 sec. to instantly cook for 30 seconds.
- To increase the time in 30 second increments (except auto cook and defrost), press Add 30 sec. repeatedly.

Note: You can not quick start when using the defrost feature.

Defrosting in your microwave

1. Press Defrost repeatedly to select "MEAT," "POULTRY," or "FISH."
2. Press START.
3. Use the number pad to enter the weight of the item to be defrosted (in pounds). For example, 10 = 1.0 lbs.

Note: You may enter any weight from 0.1 to 6.0 lbs.

4. Press START to start defrosting. The remaining cooking time is displayed. Your microwave may beep periodically to remind you to turn the food. Press START to continue.

Tips for best results:

- Use defrost only for raw food items.
- Defrosting gives best results when your food is taken directly from the freezer. If the food has been stored in a refrigerator-freezer that does not maintain a temperature of 5°F (-15°C) or below, always program a lower food weight or lower cook time to prevent cooking the food.
- Enter a reduced weight if the frozen food has been outside the freezer for more than 20 minutes.
- The shape of the food package alters the defrosting time. For example, a shallow, rectangular food package will defrost more quickly than a deep block of food.
- Separate pieces as they begin to defrost.

Tips for defrosting meat

MEAT	NORMAL WEIGHT	COOK TIME
Roast beef or pork	2.5 to 6 lbs. (40 to 96 oz.)	<ul style="list-style-type: none"> • Placed fat-side down. • After each stage, turn the food over and shield any warm portions with narrow strips of aluminum foil. • Let stand, covered for 15-30 minutes.
Steaks, chops, or fish	0.5 to 3 lbs. (8 to 48 oz.)	<ul style="list-style-type: none"> • After each stage, rearrange the food. If there are any warm or thawed portions of food, shield them with narrow flat pieces of aluminum foil. • Remove any pieces of food that are nearly defrosted. • Let stand, covered for about 5 to 10 minutes.
Ground meat	0.5 to 3 lbs. (8 to 48 oz.)	<ul style="list-style-type: none"> • After each stage, remove any pieces of food that are nearly defrosted. • Let stand, covered with foil for 5 to 10 minutes.
Whole chicken	2.5 to 6 lbs. (40 to 96 oz.)	<ul style="list-style-type: none"> • Remove giblets before freezing poultry. • Start defrosting with the breast side down. • After the first stage, turn the chicken over and shield any warm portions with narrow strips of aluminum foil. After the second stage, again shield any warm portions with narrow strips of aluminum foil. • Let stand, covered, for 30 to 60 minutes in the refrigerator.
Chicken pieces	0.5 to 3 lbs. (8 to 48 oz.)	<ul style="list-style-type: none"> • After each stage, rearrange or remove any pieces of food that are nearly defrosted. • Let stand for 10-20 minutes.

For the best results, use these suggestions when defrosting meat:

Cooking with the sensor

Sensor cooking detects the humidity released by your cooking food and adjusts the cooking time based on the type and amount of food cooking.

- Press Reheat, then press START. Your microwave automatically sets the cook time.
- When using sensor cooking:
 - Casseroles: Add 2-3 tablespoons of liquid, cover with a lid or vented plastic wrap. Stir when instructed from the display.
 - Canned foods: Place the contents into a microwave-safe dish and cover with a loose-fitting lid or vented plastic wrap. Let it stand a few minutes before serving.
 - Plates of food: Arrange food on the plate. Cover with a loose-fitting lid or vented plastic wrap. Let it stand a few minutes before serving.

Note

If additional time is needed, continue to cook manually.

Pizza

The pizza setting cooks from one to two slices (6-8 oz.) of pizza automatically.
Press Pizza, then press START.

Potato

The potato setting cooks from two to four potatoes automatically.
Poke holes in your potatoes skin 5-6 times with a fork. Do not cover your potatoes.
Press Potato, then press START.
Let the potatoes stand for about five minutes after the microwave has finished to complete cooking.

Frozen dinner

The frozen dinner setting is designed for one frozen entree or frozen convenience foods (such as frozen dinners) from 10 to 20 oz.

- Press Frozen Dinner, then press START.
- When cooking frozen dinners:
- Read the instructions on your frozen food for best results, if available.
- Make sure that moisture can escape from the packaging. All frozen dinner instructions should specify holes in the plastic covering before cooking.
- Be careful when removing the plastic covering. Remove the side facing away from you to avoid steam burns.

Dinner plate

The dinner plate setting is designed for one to two plates.

- Press Dinner Plate, then press START.

Rice

The rice setting cooks one to two cups of rice automatically (starting from room temperature).

- Press Rice, then press START.

Vegetables

The vegetable sensor feature cooks from one to four cups of fresh vegetables (when starting at room temperature).

1. Press Vegetable repeatedly to select the number of cups:

SERVINGS	PRESS VEGETABLE BUTTON...
1 cup	Once
2 cups	2 times
3 cups	3 times
4 cups	4 times

1. Press START.

DO NOT leave the microwave unattended while popping popcorn.

Popcorn

1. Press Popcorn repeatedly to select your popcorn bag's weight:

WEIGHT PRESS POPCORN BUTTON...
3.5 oz. Once
3.0 oz. 2 times
1.75 oz. 3 times

2. Press START.

Beverage

The beverage setting heats one to three cups of a beverage. Use the table below to determine the setting to use.

1. Press Beverage repeatedly to select the number of servings:

SERVINGS PRESS BEVERAGE BUTTON...
1 cup Once
2 cups 2 times
3 cups 3 times

2. Press START.

Using the stop/clear button

Press STOP/CLEAR to:

- Erase information that you entered incorrectly
- Cancel the timer
- Pause the microwave during cooking (press START to resume)
- Display the clock after cooking is completed
- Cancel a programming during cooking (press twice)

Using the light

- To use the light underneath your microwave, press Light repeatedly to cycle between high brightness, low brightness, or off.

Note: To change a light bulb, see "Replacing the light" on page 19.

Using the vent fan

Your microwave's vent fan works as a range hood to filter out smoke and other odors from cooking.

- Press Vent Fan repeatedly to cycle between high speed, low speed, or off.
- The fan automatically starts when heat rises from range surface units or burners and stops once the unit temperature decreases. It cannot be turned off manually during this time. This protects the microwave from excessive temperatures.

Using the turntable

For best results, leave the turntable on. However, you can turn it off for large dishes.

- Press the Turntable on/off to turn your turntable on or off.

Using the child lock

- To lock the microwave, press and hold STOP/CLEAR for three seconds. The microwave beeps and a lock indicator appears on the display.
- To unlock the microwave, press and hold STOP/CLEAR until the lock indicator disappears (about three seconds).

MAINTENANCE

Cleaning the outside of your microwave

Exterior

The outside surfaces are pre-coated steel and plastic. Clean the outside with mild soap and water, then rinse and dry with a soft cloth. Do not use any type of household or abrasive cleaner.

Door

Wipe the window on both sides with a damp cloth to remove any spills or splatters. Metal parts will be easier to maintain if wiped frequently with a damp cloth. Avoid the use of spray and other harsh cleaners as they may stain, streak or dull the door surface.

Control panel

If the control panel is dirty, clean the microwave door before cleaning. Wipe the panel with a cloth dampened slightly with water only. Dry with a soft cloth. Do not scrub or use any sort of chemical cleaners. Close the door and press STOP/CLEAR to clear any instructions you may have pressed.

Cleaning the inside of your microwave

Interior

Wipe with a soft cloth and warm water. Do not use abrasive or harsh cleaners or scouring pads. For baked-on food, use baking soda or a mild soap, then rinse thoroughly with hot water. To help loosen baked-on food particles or liquids, heat a cup of water (add lemon juice if you want to keep your microwave from smelling) in a microwave-safe mug or bowl on high power for five minutes or until boiling. Let it cool in the microwave, then wipe the interior with a soft cloth.

Waveguide cover

The waveguide cover located on the right wall inside your microwave. Keep the waveguide cover free of any food material for performance. Carefully wipe with a damp cloth and keep free from the surface of the cover. Remove carefully with a dry cloth. Be especially careful not to damage the cover or to allow any liquid to enter the waveguide opening.

Removing odors

Occasionally, a cooking odor may remain in the microwave. To remove, combine one cup of water, lemon juice, and several whole cloves in a two-cup glass measuring cup. Boil for several minutes at high power, then let it cool in the microwave. The interior should smell fresh.

Cleaning the turntable

Turntable and turntable support

- Remove the turntable and turntable support to wash them in mild, sudsy water. For stubborn stains, use a mild abrasive cleaner or scouring pads. Rinse and turn to wash them then let them air dry before using.
- Do not use the turntable if the turntable support roller ring is damaged. Do not wash the turntable support roller ring in the dishwasher.

CAUTION: Do not operate the microwave without the turntable properly in place.

- 1 To remove the exhaust filters, slide the filter toward the back of the microwave, then pull it downward while sliding it out of the side slot. Repeat for the second filter.

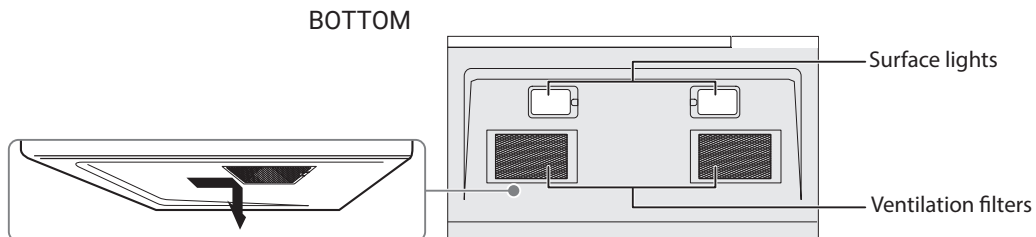

- 2 Soak the ventilation filters in hot water using a mild detergent or wash in a dishwasher. Rinse well and shake to dry.

CAUTION: Do not use ammonia. The aluminum on the filter will corrode and darken.

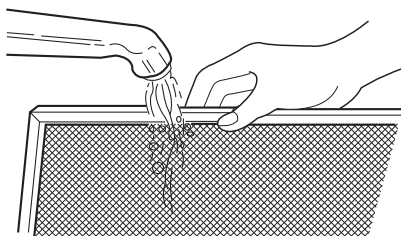

- 3 To reinstall the exhaust filter, slide it into the side slot; then push up and toward the front of the microwave to secure it. Repeat for the second filter.

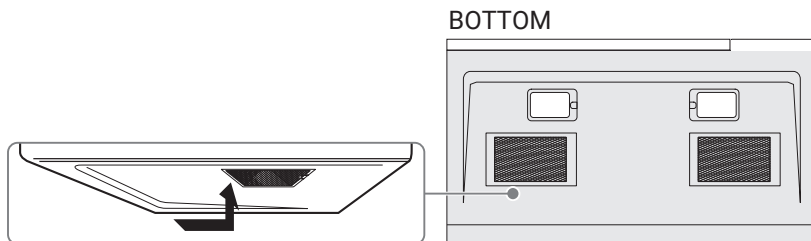

Replacing the charcoal filter

The charcoal filter is used in non-vented, recirculated installations. The filter should be changed every 6 to 12 months depending on use.

- 1 Unplug the microwave oven or turn off power at the main circuit breaker.
- 2 Remove the vent grill screws.
- 3 Pull the vent grill away from the unit.

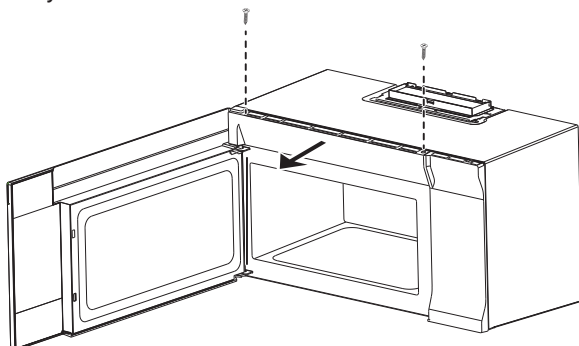

- 4 Remove the charcoal filter by pushing it inwards, then lift up and pull it out of the microwave.

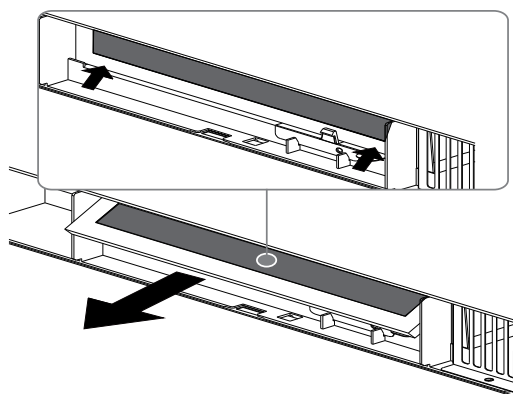

- 5 Insert the new charcoal filter, close the vent grill, and secure with the vent grill screws.
- 6 Plug the microwave back in or turn the power back on at the main circuit breaker.

Replacing the lights

Surface light (external)

- 1 Unplug the microwave oven or turn off power at the main circuit breaker.
- 2 Remove the light cover screws under the microwave.

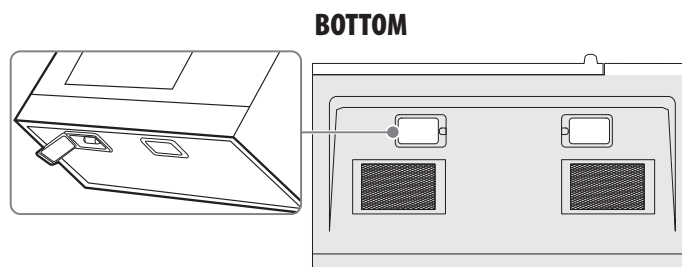

- 3 Remove the old light bulbs and replace with new 1.2W LED lights.
- 4 Reinstall the light cover screws to secure the covers.
- 5 Plug the microwave back in or turn the power back on at the main circuit breaker.

Microwave light (internal)

- 1 Unplug the microwave oven or turn off power at the main circuit breaker.
- 2 Remove the vent grill screws.
- 3 Pull the vent grill away from the unit.

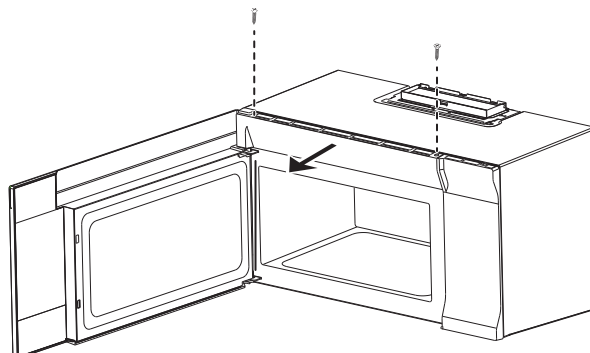

4 Remove the charcoal filter by pushing it inwards, then lift up and pull it out of the microwave.

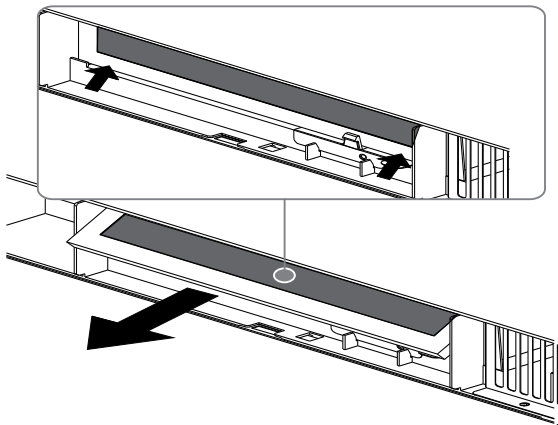

5 Push the tab to release the light cover and carefully pull it up from the front edge.

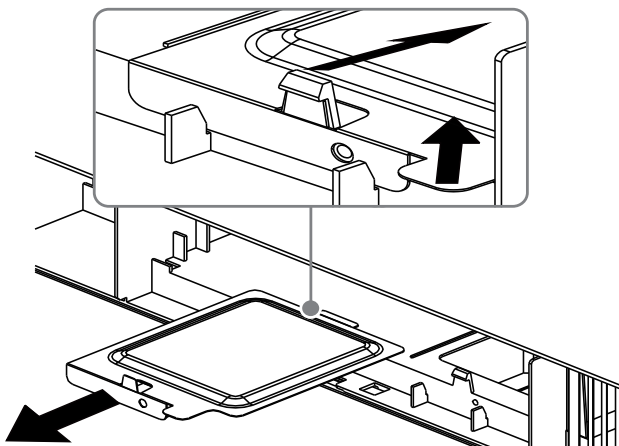

6 Remove the LED module and replace only with an equivalent 1.2 watt LED bulb.

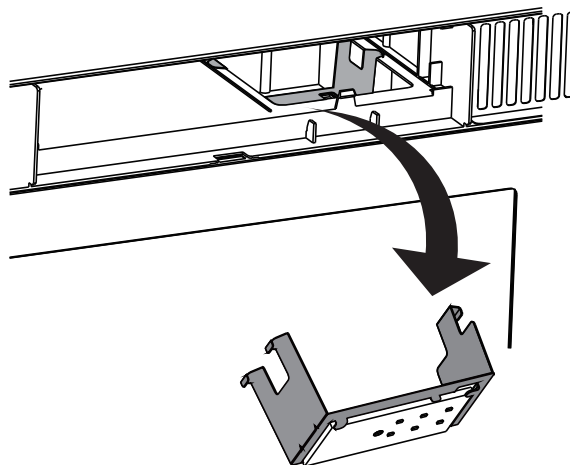

7 Carefully push the light cover back into place.

8 Replace the charcoal filter. Push the vent grill back into place (engaging both the bottom and top tabs) and replace the vent grill mounting screws.

TROUBLESHOOTING

If you have a problem with your microwave, review the following chart for a possible solution. If the microwave still does not work properly, contact the nearest authorized service center.

PROBLEM	POSSIBLE CAUSE	POSSIBLE SOLUTION
Microwave will not start	The electrical cord is not plugged in.	Plug in the electrical cord.
	The door is open.	Close the door and try again.
	The wrong operation is set.	Check the instructions and try again.
Arcing or sparking in the microwave	You are attempting to use incorrect materials in the microwave.	Use only microwave-safe materials.
	You are attempting to use the microwave when it's empty.	Do not operate the microwave when it's empty.
	Spilled food remains in the microwave.	Clean the microwave with a wet towel.
Unevenly cooked foods	You are attempting to use incorrect materials in the microwave.	Use only microwave-safe materials.
	The food is not defrosted completely.	Defrost the food completely before attempting to cook it.
	The cooking time or power level is not adequate to cook the food.	Use the correct cooking time and power level.
	The food is not turned or stirred.	Turn or stir the food.
Overcooked foods	The cooking time or power level is not adequate to cook the food.	Use the correct cooking time and power level.
Undercooked foods	You are attempting to use incorrect materials in the microwave.	Use only microwave-safe materials.
	The food is not defrosted completely.	Defrost the food completely before attempting to cook it.
	The cooking time or power level is not adequate to cook the food.	Use the correct cooking time and power level.
	The microwave ventilation ports are blocked or restricted.	Make sure that the ventilation ports are not blocked or restricted.
Improper defrosting	You are attempting to use incorrect materials in the microwave.	Use only microwave-safe materials.
	The cooking time or power level is not adequate to cook the food.	Use the correct cooking time and power level.
	The food is not turned or stirred.	Turn or stir the food.
The vent fan turns on by itself	The fan automatically starts when heat rises from range surface units or burners and stays on until the temperature decreases. This protects the microwave from excessive temperatures.	Your microwave is operating normally. The fan cannot be turned off manually during this time.
The turntable will not move	The turntable is misaligned.	Make sure that the turntable is properly aligned on the ring and shaft.
	The turntable is turned off.	Press Turntable on/off to turn your turntable back on.

Obtaining replacement parts

Specifications

Model	
Rated voltage	120V / 60 Hz
Rated input power	1550W
Rated output power	1000W
Microwave capacity	1.6 cu. ft.
Turntable diameter	13.5 in. (34.5 cm)
External dimensions (WxHxD)	31.3 × 16.4 × 15.0 in. (79.5 × 41.7 × 38.2 cm)
Internal dimensions (WxHxD)	20.24 × 9.25 × 14.41 in. (51.4 × 23.5 × 36.6 cm)
Certifications	UL approved
Power cord length	3.3 ft. (1 m)
Net weight	56 lbs. (25.4 kg)