



USER MANUAL

PIZZA OVEN

KoolMore Outdoor Kitchen System Wood Fired Pizza Oven

Model:
KM-OKS-WFPO

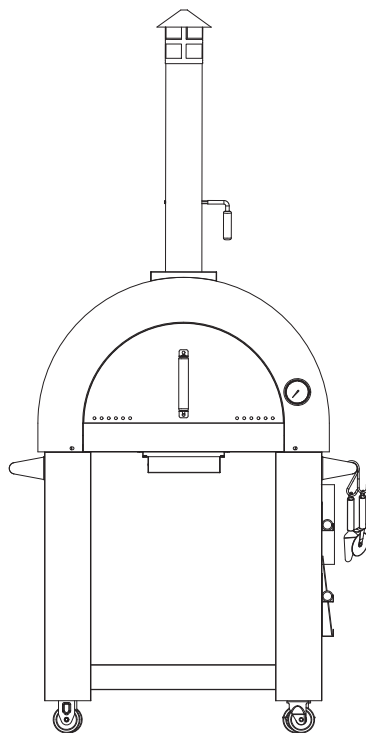

Before using, please read the operating instructions carefully to ensure proper application and achieve satisfactory results.

***For any service-related issues, please contact
us: Phone Number: 718-576-6342
Email address: support@koolmore.com***

Safety Precautions

1. Prior to Assembly and Use

Please ensure you fully read and understand the provided assembly and use instructions prior to the construction and utilization of the Outdoor Wood Fired Pizza Oven.

2. Placement

Position the Outdoor Oven on a surface that is non-combustible to prevent any accidental fires. The surface should be stable and level to ensure safe operation.

3. Appropriate Cooking Utensils

Utilize cooking utensils such as peels, brushes, and cookware that are specifically designed for wood-fired cooking.

4. Initial Heat Up

For the initial cooking on the barbecue, heat the oven and maintain the fuel red hot for at least 30 minutes. This is crucial for your barbecue's optimal performance.

5. Temperature Management

Avoid overheating your Outdoor Oven as extreme temperatures can cause permanent damage. Gradually bring the oven to temperature by starting with a small fire at the center. Once stable, shift the fire to the oven's left side, adding small amounts of wood until the oven reaches an even, high heat. An ideal pizza baking temperature is achieved when the Cooking Stone is within the range of 620°F to 650°F.

6. Fuel Selection

Start your fire using small kindling and newspaper. Avoid using chemical fuel starters such as starting fluids as they can contaminate the cooking surface and cause irreversible damage to your Outdoor Oven.

7. Pre-Cooking Procedure

Prior to cooking, ensure the fuel is adequately covered with a coating of ash.

8. Cleaning

Only clean the oven once it is completely cool. Use a metal bristle brush or a damp cloth to clean the Cooking Stone. Avoid using chemical cleaners to prevent any damage.

Safety Precautions

9. Lighting and Re-lighting

For safety reasons, do not use spirit or petrol for lighting or re-lighting your oven.

10. Child and Pet Safety

Always keep children and pets at a safe distance from the Outdoor Oven. It can become very hot during operation and pose a burn risk.

11. Moving the Oven

Do not attempt to move the oven during operation due to high temperatures.

12. Approved Firelighters

Use only firelighters that comply with EN 1860-3 standards.

13. Indoor Use

The Outdoor Oven is strictly for outdoor use only.

14. Use in Confined Spaces

Avoid using the Outdoor Oven in confined or habitable spaces like houses, tents, caravans, motor homes, or boats due to the risk of carbon monoxide poisoning.

Your safety is paramount. Always adhere to these precautions when using your Outdoor Wood Fired Pizza Oven. Enjoy your cooking experience responsibly.

Assembly Instructions

Step 1: Bottom Shelf Installation

Start by installing the bottom shelf using sixteen 1/4" * 0.59" (15mm) screws.

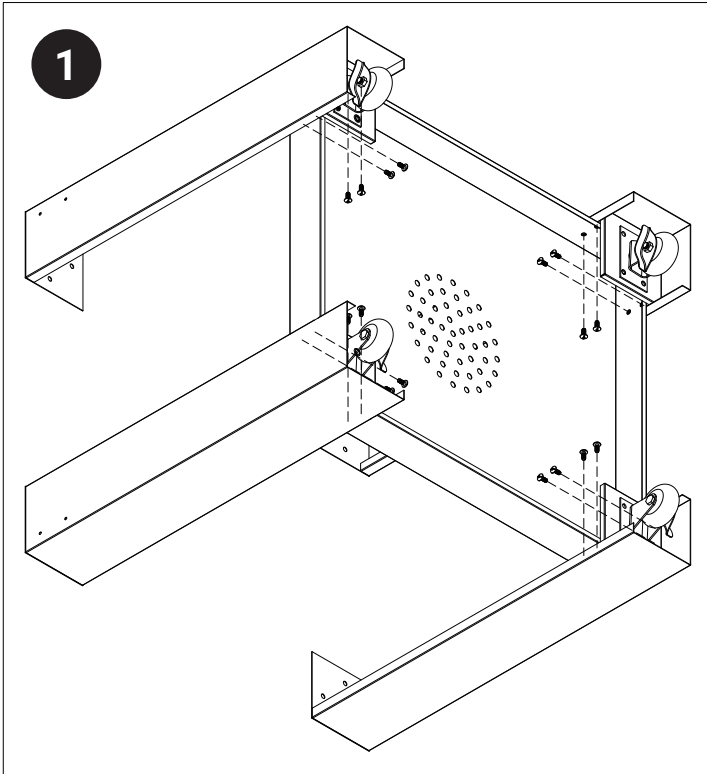

* The bottom shelf provides stability and a storage area for your cooking essentials.

Step 2: Attaching the Legs

Fasten the oven body to the legs using twelve 1/4" * 0.59" screws.

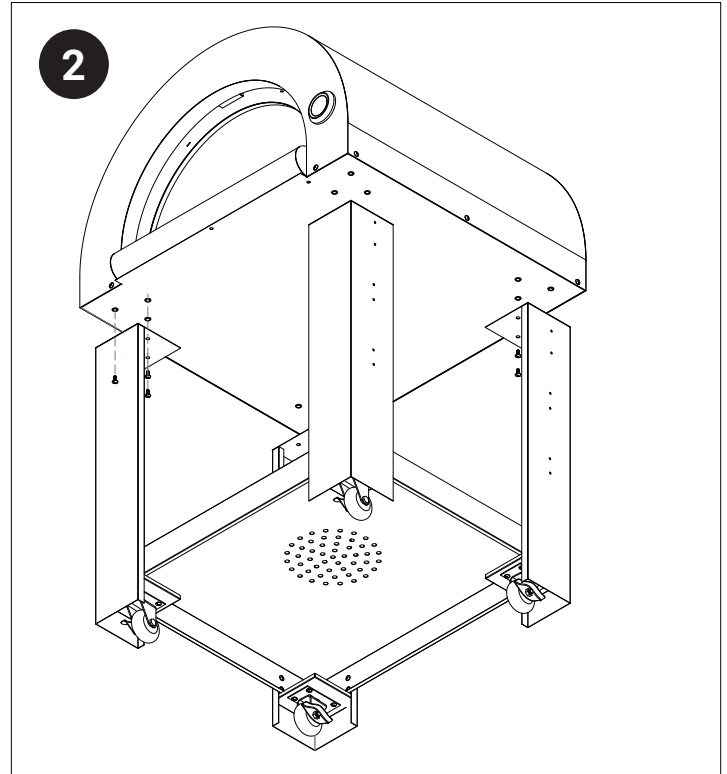

* The legs are crucial in raising the oven off the ground to an optimal cooking height.

Assembly Instructions

Step 3: Ash Support Installation

Install the ash support using four 1/4" * 0.59" screws.

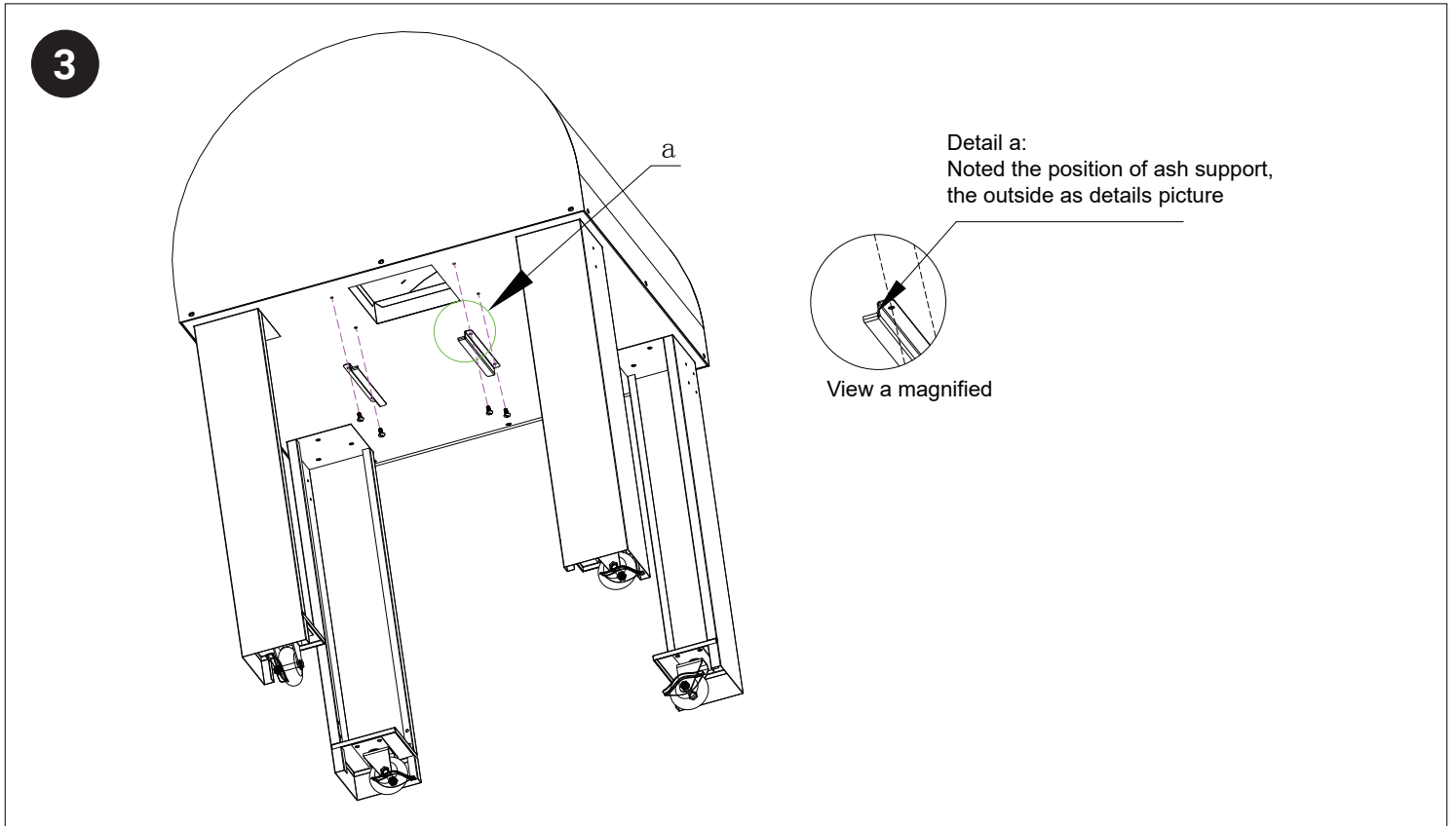

* The ash support holds the ash box, enabling easy cleanup after cooking.

Assembly Instructions

Step 4: Installing the Ash Box

Place and secure the ash box on the bottom of the oven.

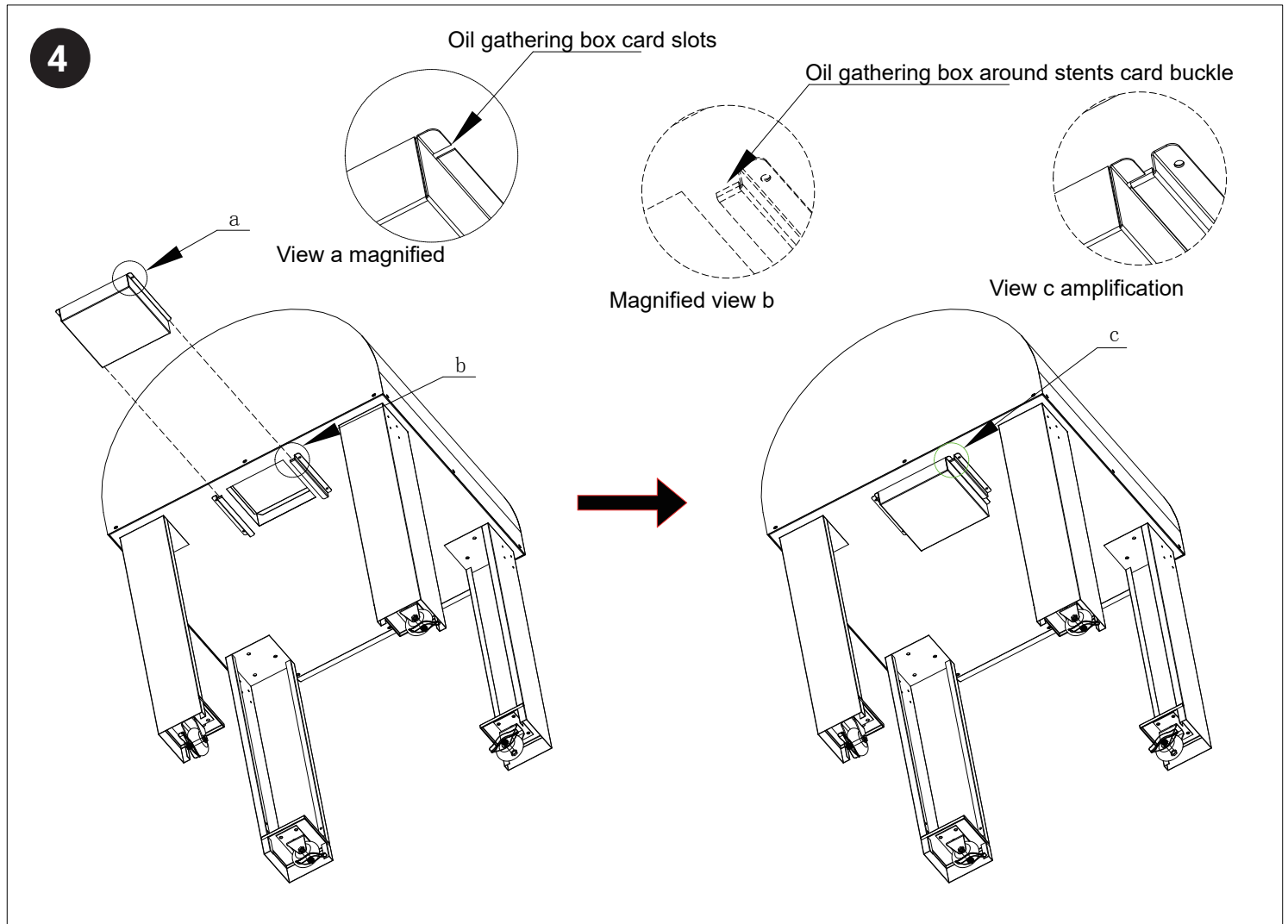

* Ensure the ash box fits snugly and securely in its designated spot. Its proper placement is essential for the oven's safe and efficient operation.

Assembly Instructions

Step 5: Door Handle Installation

Secure the door handle with two sets of 1/4" * 0.59" screws, insulation mat, flat washer, spring washer, and 1/4" bolts.

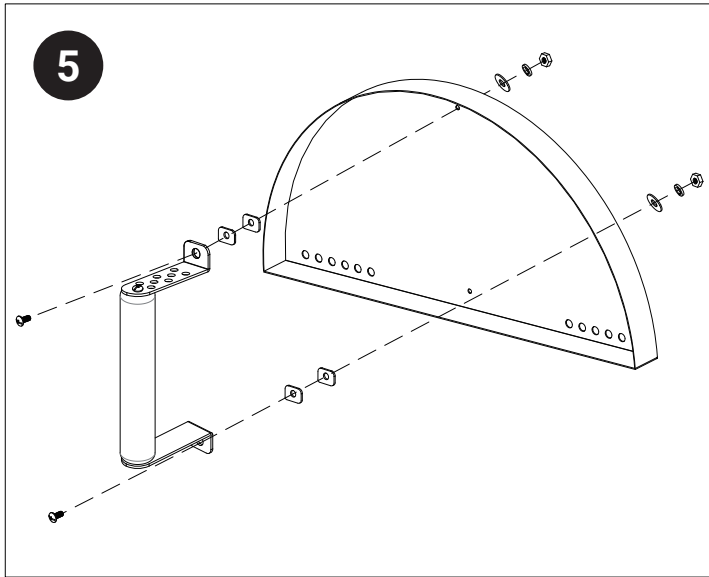

- * This handle facilitates easy opening and closing of the oven door.

Step 6: Chimney Cap Installation

Attach the chimney cap using four 5/32" * 0.39" screws.

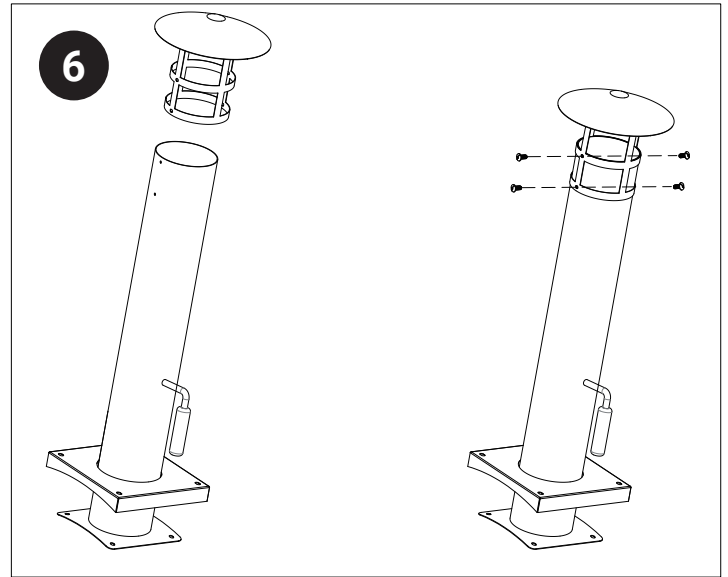

- * The chimney cap plays a key role in directing smoke away from the oven and controlling draft.

Assembly Instructions

Step 7: Chimney Installation

Install the chimney using four 1/4" * 0.59" screws.

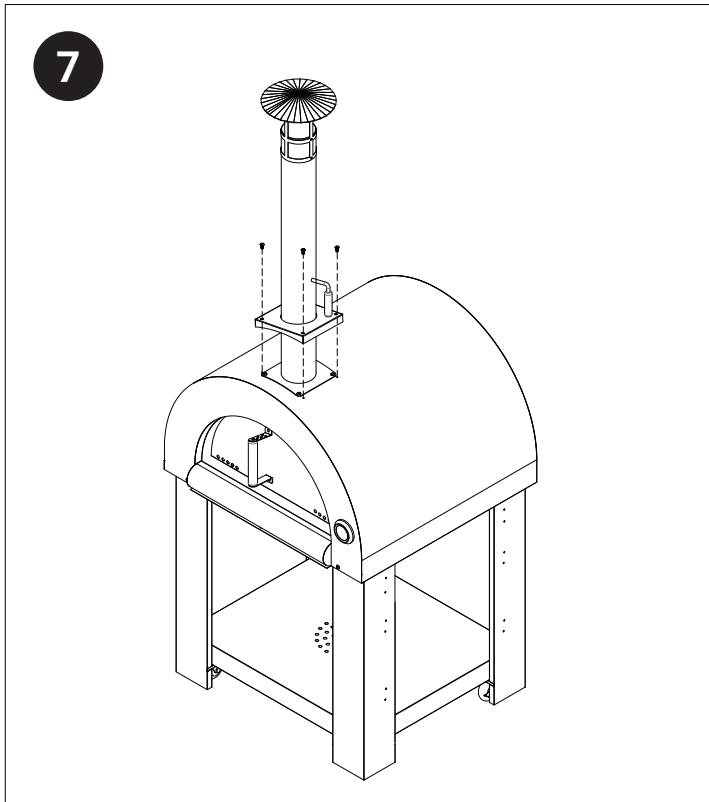

* This handle facilitates easy opening and closing of the oven door.

Step 8: Chimney Box Installation

Secure the chimney box with four 1/4" * 1.18" screws.

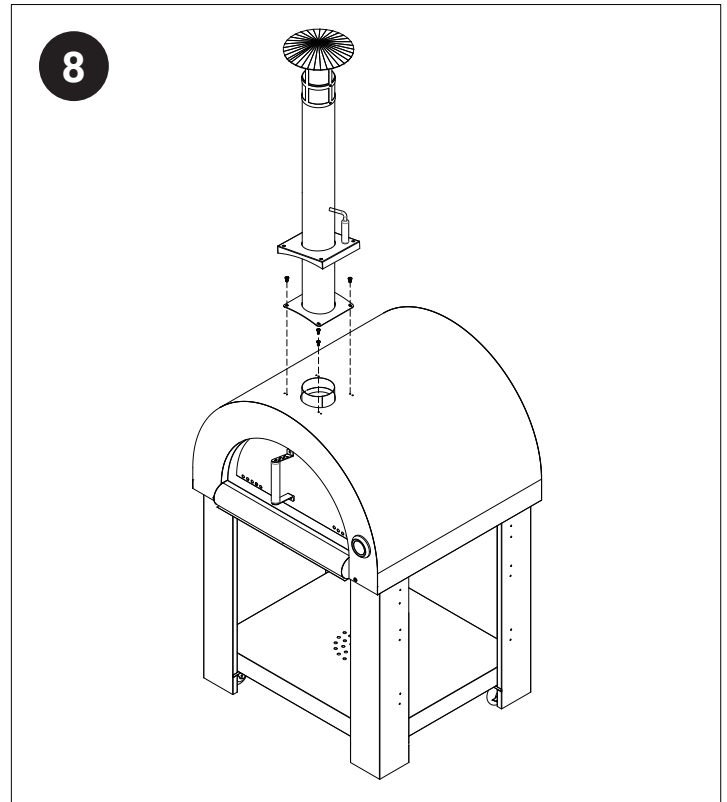

* The chimney cap plays a key role in directing smoke away from the oven and controlling draft.

Assembly Instructions

Step 9: Installing Left and Right Handles

Fasten the left and right handles using eight 1/4" * 0.59" screws.

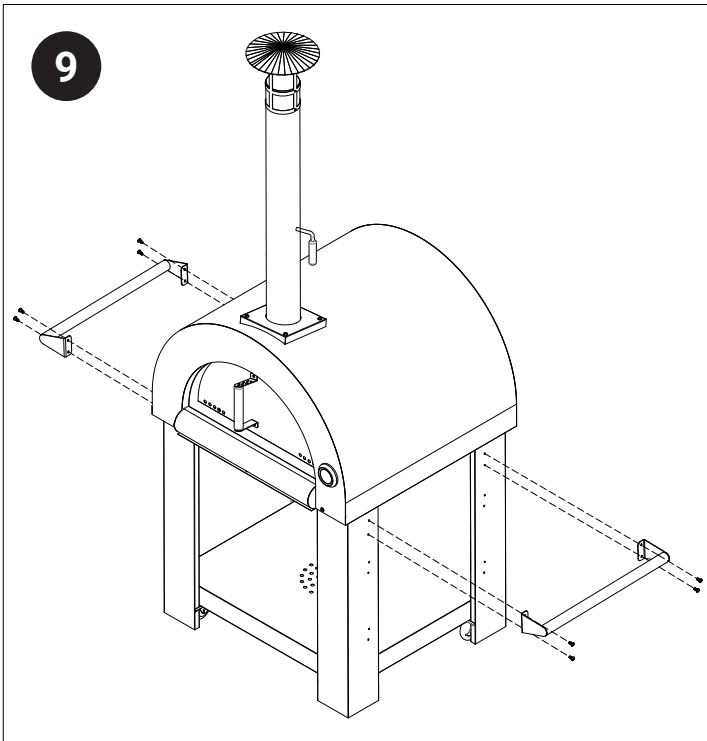

* These handles are essential for maneuvering and positioning the oven.

Step 10: Installing Hooks

Fix three hooks and one pc of hook using eight 1/4" * 0.59" screws.

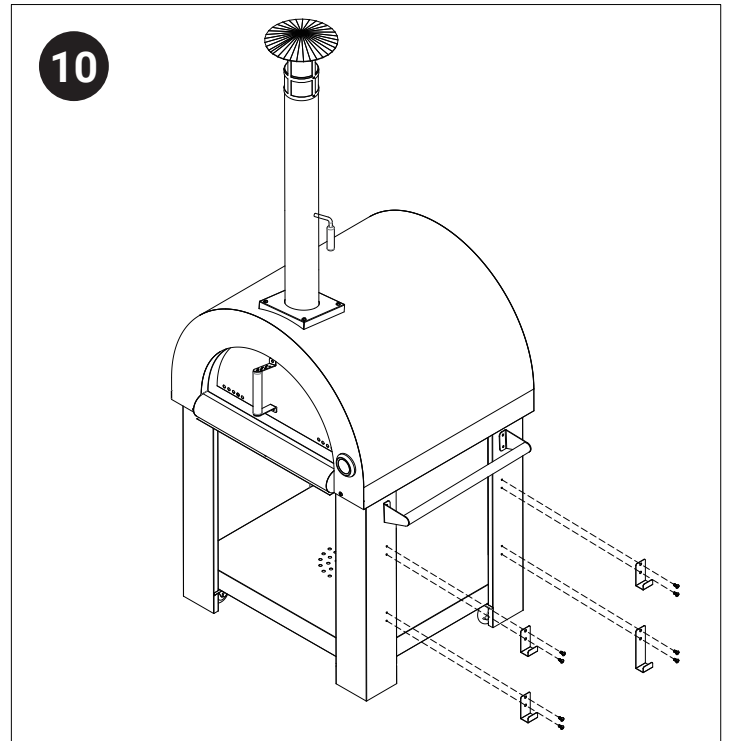

* These hooks offer convenient hanging storage for cooking utensils.

Assembly Instructions

Step 11: Hanging 'S' Hooks

Attach four 'S' hooks onto the handle.

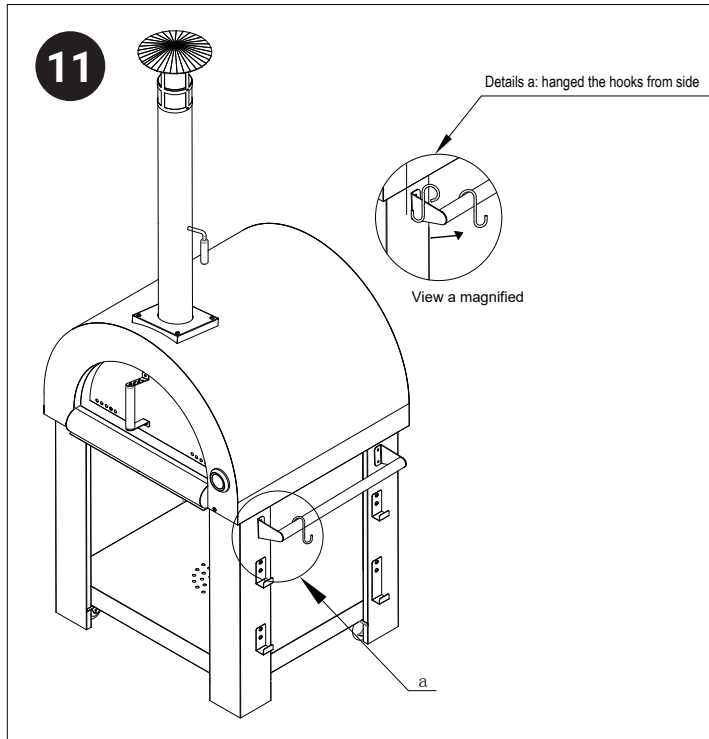

- * These hooks provide additional storage space and easy access to your cooking utensils while using the oven.

Step 12: Parts Placement

Follow the diagram to position the remaining parts as indicated.

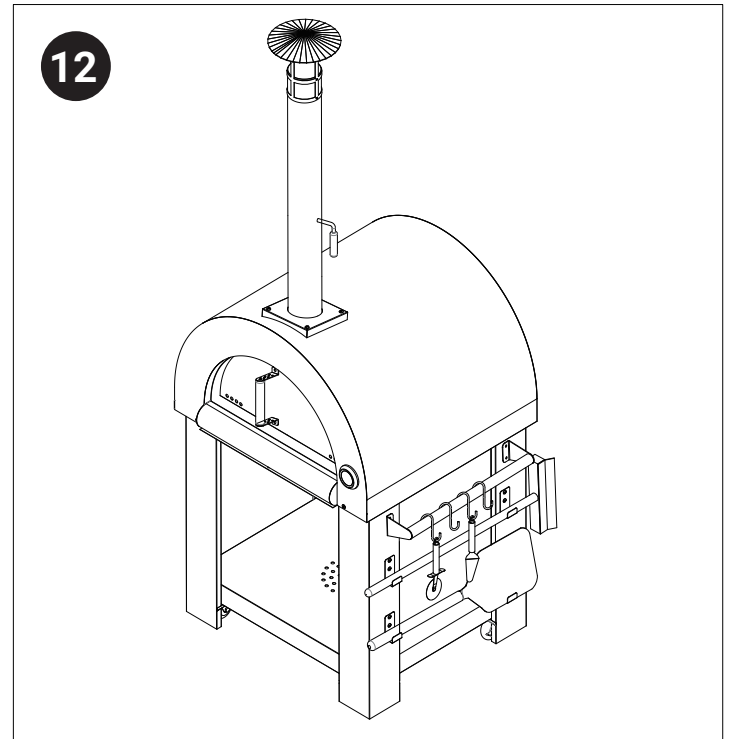

- * Proper placement ensures the best performance and safety of your oven.

Assembly Instructions

Step 13: Installing Handle and Side Table

Mount the handle and side table as shown in the illustration. Remember, the side table can be installed on either the left or right side, based on your preference and convenience.

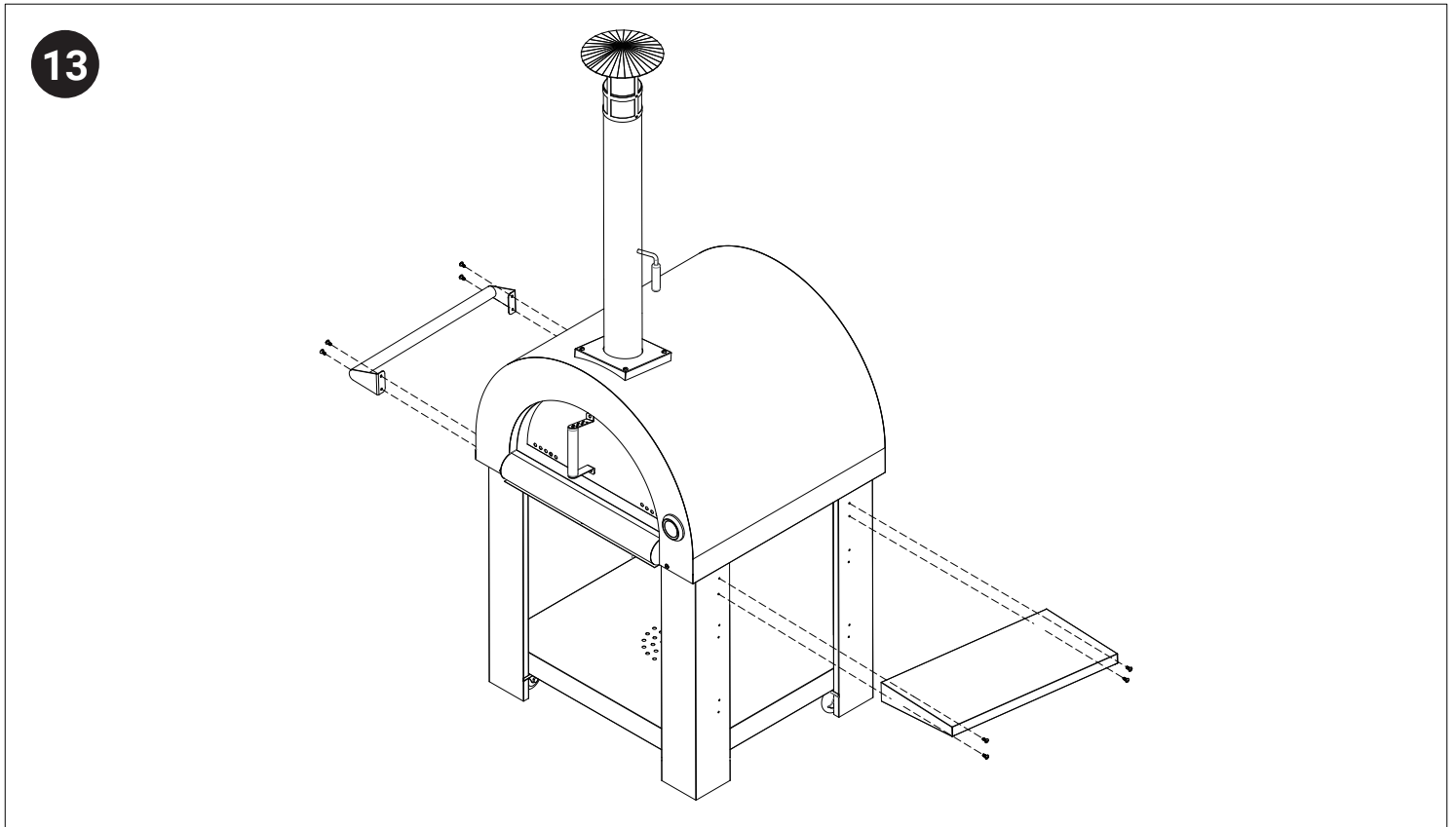

Double-check the stability of the handle and side table after installation. The handle ensures easy maneuverability of your oven, and the side table provides additional space for your cooking supplies, enhancing your overall cooking experience.

Congratulations! With these steps completed, you are ready to enjoy your KoolMore Outdoor Wood Fired Pizza Oven. Please review all previous steps to confirm secure assembly, and ensure you understand the safety precautions before use. Happy cooking!

Getting Started

Unpack your Wood-fired Outdoor Oven with care, using two people for safe lifting. Place the oven on a non-combustible stand like the Kitchen Wood Box/Stand kit with granite top. Remove all protective film. Assemble the oven as per the included instructions. Prior to its first use, 'season' your oven by heating it to 650°F at least twice, letting the fire die down each time.

Introduction to Wood-Fired Cooking

Your Outdoor Oven operates similarly to a home oven, but adds unique flavor through wood-firing. It allows for a variety of cooking methods, from baking pizzas and breads to roasting meats and vegetables. The Cooking Stone and Dome radiate heat, creating a natural convection effect, while the side fire gives a unique crisp, smoky taste.

Use oven-safe metal, ceramic, or glass pans, but ensure they're kept away from the flame and used below 650°F.

Choosing the Right Wood

Use dry hardwoods like oak or beech. Avoid resinous wood like pine or spruce and never use treated lumber. If you see a lot of black smoke, it usually indicates the wrong type of wood is being used.

Ignition and Heat Management

Mastering the fire-building art is key to achieving evenly distributed high temperatures on your Cooking Stone. Start the fire an hour before cooking. Split wood into small, 10" long and 0.5" thick pieces.

Using kindling and newspaper, start a match-lit fire in the center of the Cooking Stone.

Once well-established, move it to the left side of the oven.

Aim for a Cooking Stone temperature between 620°F-650°F before cooking.

Cooking Guidelines

- 1. High-Temperature Cooking:** Best suited for pizzas. Achieve this by heating your Cooking Stone between 620°F and 650°F. For optimal cooking, place the pizza on the Cooking Stone using the 11.5" Square Peel and rotate it during cooking with the 8.5" Round Peel.
- 2. Medium-Temperature Cooking:** Perfect for roasting meats, vegetables, fish, and seafood. Aim for a Cooking Stone temperature between 450°F and 600°F. Depending on your dish, it might be beneficial to cover it initially for even cooking before removing the cover for browning. Remember to rotate your dish periodically for uniform cooking.
- 3. Low-Temperature Cooking:** Ideal for baking breads, pies, and other desserts. This is achieved when your Cooking Stone is between 325°F and 425°F. Preheating the Cooking Stone to 500°F or higher for at least 15 minutes is recommended before removing all embers for low-temperature cooking.
- 4. Safety Tips:** Always use heat-resistant barbecue mitts when handling hot cookware or adjusting oven vents. Also, ensure you're wearing grill gloves compliant with directive 89/686/EEC, for example: performance level 2 for resistant contact heat, in accordance with DIN EN 407.

Cleaning and Maintenance

- 1. Oven Cleaning:** Wait until your Outdoor Oven has cooled down before starting the cleaning process. Use the 11.5" Square Peel and the Ash Sweep to brush off all ash and food debris from the Cooking Stone. Avoid using water to extinguish the fire as it can cause damage to the oven.
- 2. Cooking Stone Cleaning:** For cleaning the surface of your Cooking Stone, use a damp cloth or a soft brush to gently remove any food residues. It's recommended to avoid any chemical cleaners as they can affect the stone's surface and potentially impact the flavor of your food.
- 3. General Maintenance:** Regular cleaning and maintenance of your Outdoor Oven will prolong its life and ensure it remains safe and efficient. Keep an eye out for any potential wear and tear, particularly on the door hinges, handles, and the vent.