

STEAM TABLE

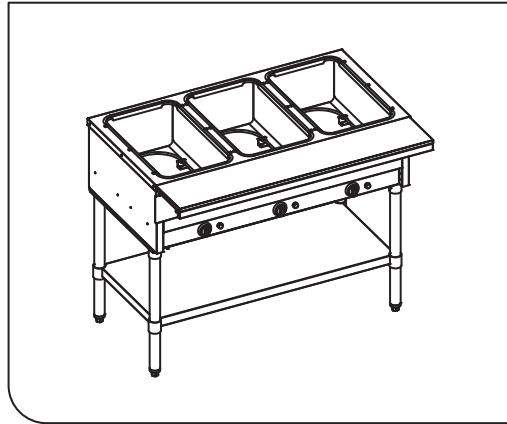

KM-OWS-3

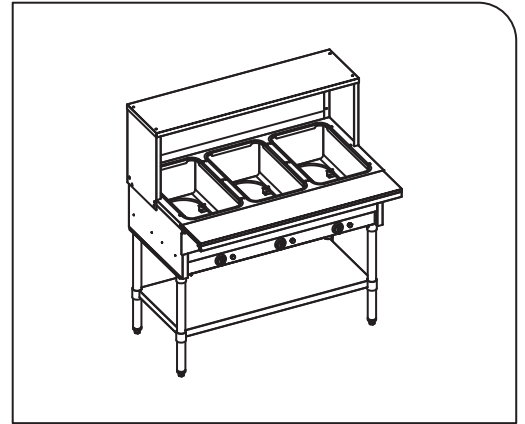

KM-OWS-3SG

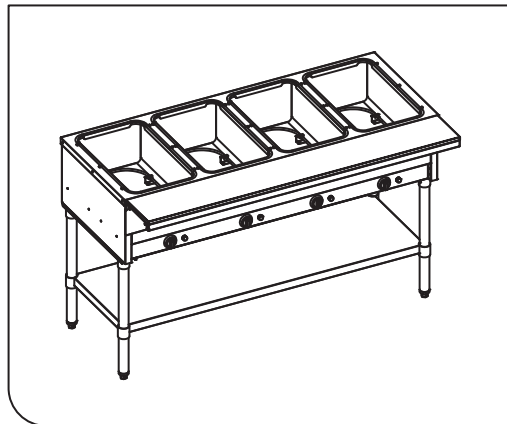

KM-OWS-4

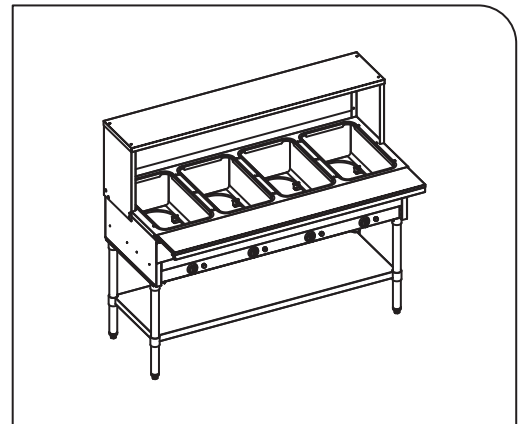

KM-OWS-4SG

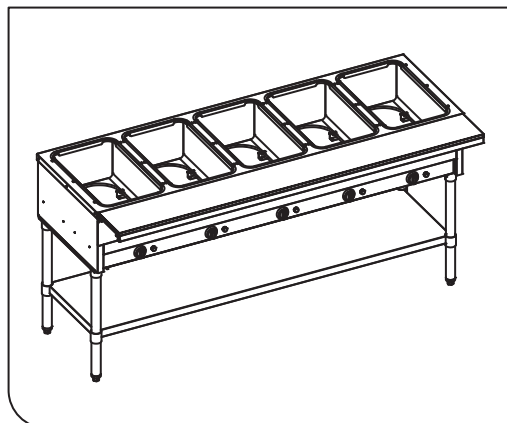

KM-OWS-5

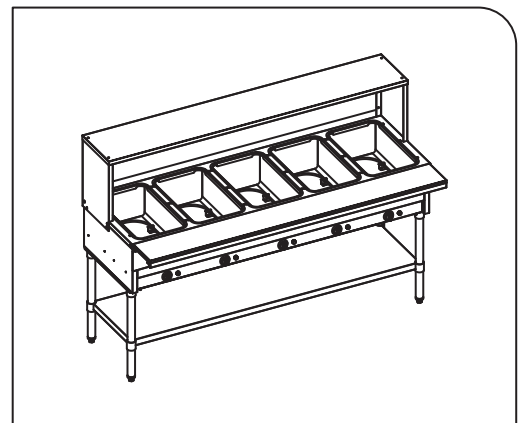

KM-OWS-5SG

Intended for other than household use. Unit must be kept clear of combustibles at all times.



WARNINGS

- Do not touch any hot surfaces.
- Do not plug or unplug unit with wet hands.
- Do not immerse unit, cord or plug in liquid at any time.
- Unplug cord from outlet when not in use and before cleaning.
- Do not operate unattended.
- Do not use this unit for anything other than intended use.
- Do not use outdoors.
- Operate the unit with legs provided to prevent overheating of surfaces below.
- Do not use if unit has a damaged cord or plug, in the event the appliance malfunctions, or has been damaged in any manner.
- Keep children and animals away from unit.
- Any incorrect installation, alterations, adjustments and/or improper maintenance can lead to property loss and injury. All repairs should be done by authorized professionals only.
- Ensure that the designated power supply is adequate for continual usage and the voltage is correct.

ASSEMBLY

NOTE – Legs and under-shelf must be assembled before securing legs to the table.

Standard Adjustable under-shelf

- 1** Remove the unit from the shipping carton and packaging.
- 2** Inspect the contents to ensure there is no damage to the unit.
- 3** Rest table on its top with gussets facing up. (use cardboard or other material to prevent scratching top)
- 4** Install legs into gussets. Make sure the rivet in leg is closer to gusset than to foot end.
- 5** Align under-shelf gussets with legs and slide under-shelf down legs to desired position. (DO NOT force or beat corners as damage could occur)
- 6** Tighten set screws in under-shelf gussets to secure under-shelf and install feet into legs using a rubber mallet.
- 7** Tighten set screws in gussets to secure legs to table.
- 8** Place table on back with control knobs up.
- 9** See next page.

For any service-related Issues, please contact us:

Phone Number: 718-576-6342

Email address: support@koolmore.com

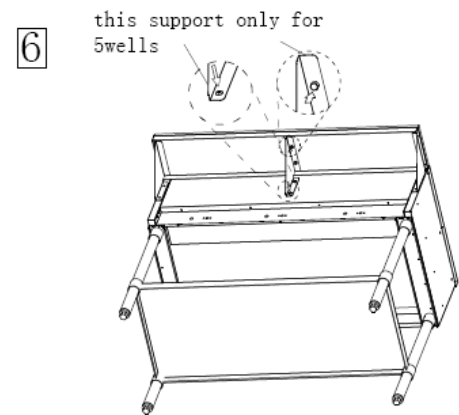
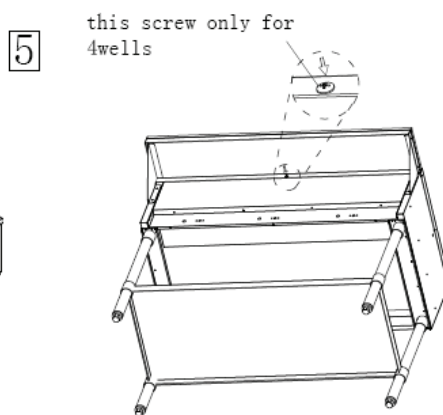
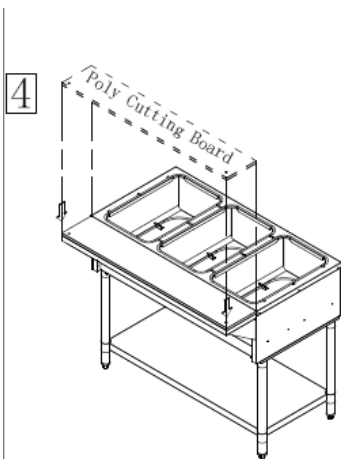
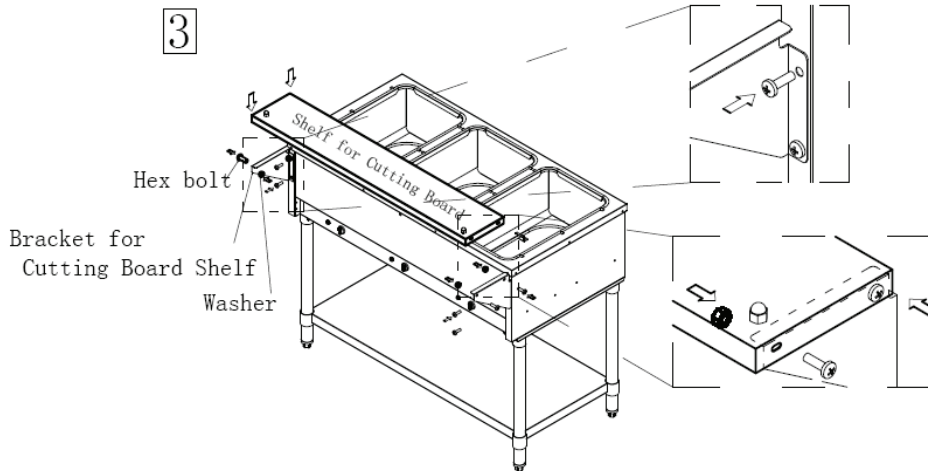
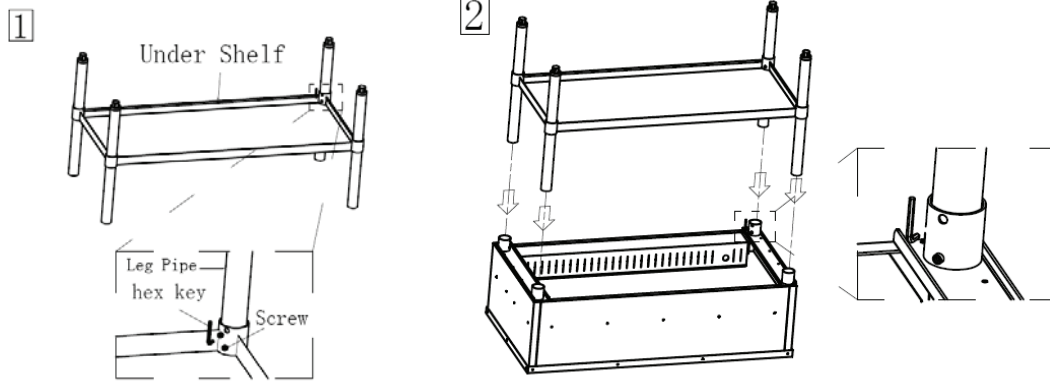



O series (open well) Operation

1. Dry Operation with over

- 1) Plug unit into appropriate electrical power supply receptacle.
- 2) With openings covered, set dial on highest position for 45 minutes to preheat unit.
- 3) During initial start-up, smoke or odor may be detected (a small amount). This will occur when the coating on the heating element burns off and should stop approximately a half hour after start up.
- 4) Place precooked food (minimum 160 F) in food pans, place in openings and cover with lids. (Indicator light is the set point for the control knob)
- 5) Adjust to desired setting for proper food temperature. This will vary with the type of food, size of pans and individual serving temperatures. NSF requires food to be a minimum of 150 F.
- 6) To increase temperature, turn knob toward highest setting. To decrease, turn toward lowest setting.
- 7) Food pans should be covered to maintain temperature when food is not being served and to prevent food from drying out.

2. Wet Operation with Cover (Spillage pans required)

Note - DO NOT put hot water in heating well or on element

- 1) With openings covered, set dial at highest setting for 45 minutes.
- 2) Install spillage pans and spillage pans to bottom of food pans with hot water (minimum of 185°F).
- 3) Place pre-cooked food (minimum 160°F) in food pans.
- 4) Place in spillage pans and cover food pans with lids.
- 5) Adjust to desired setting for proper food temperature. NSF requires food to be a minimum of 150°F.

For any service-related Issues, please contact us:

Phone Number: 718-576-6342

Email address: support@koolmore.com

S/SO/SD Series (sealed well) Operation

1. Before the unit is used for the first time, turn the temperature knob to “10” and heat the well for 20-30 minutes. Do not be alarmed if smoke appears; this preheat should burn off any residue or dust on the heating element.



WARNING: Steam can cause serious burns.

Always wear some type of protective covering on your hands and arms when removing lids or pans from the unit. Lift the lid or pan in a way that will direct escaping steam away from your face and body.

2. Never place food directly into the well. Always use pans.
3. Wet operation is recommended.
4. Always place covers on pans when not serving to prevent food from drying out and to reduce your operating costs.
5. For most efficient operation, keep empty, covered insets in each well during preheating and when the well is not in use.
6. Wet Operation

- 1) Fill food well with two (2) quarts of water. For quicker pre-heating, use hot water to till the well.
- 2) Turn the control to “HIGH” and pre-heat the warmer for 30 minutes.
- 3) After pre-heating, set the control to your desired serving temperature.
- 4) Never pour water into a well that has been heated dry. This may cause well to crack and leak.
- 5) Always fill well before preheating or before water level is below 1/2”.

CLEANING - NOTE: To maintain cleanliness and increase service life, the steam table should be cleaned daily. Do not immerse the unit in water or any other liquid. If liquid enters the electrical compartment, it may cause a short circuit or electrical shock.

- 1 Allow unit to completely cool before cleaning.
- 2 Disconnect the cord from the outlet.
- 3 Wipe the inside and outside surfaces of the unit with a damp cloth, then wipe dry.
- 4 To avoid damage, do not use abrasive cleaners or scouring pads.
- 5 Avoid using cleaners as the chemical residue could damage or corrode the surfaces of the unit. Clean the unit with warm soapy water and soft cloth only.

For any service-related Issues, please contact us:

Phone Number: 718-576-6342

Email address: support@koolmore.com

Wiring Diagram

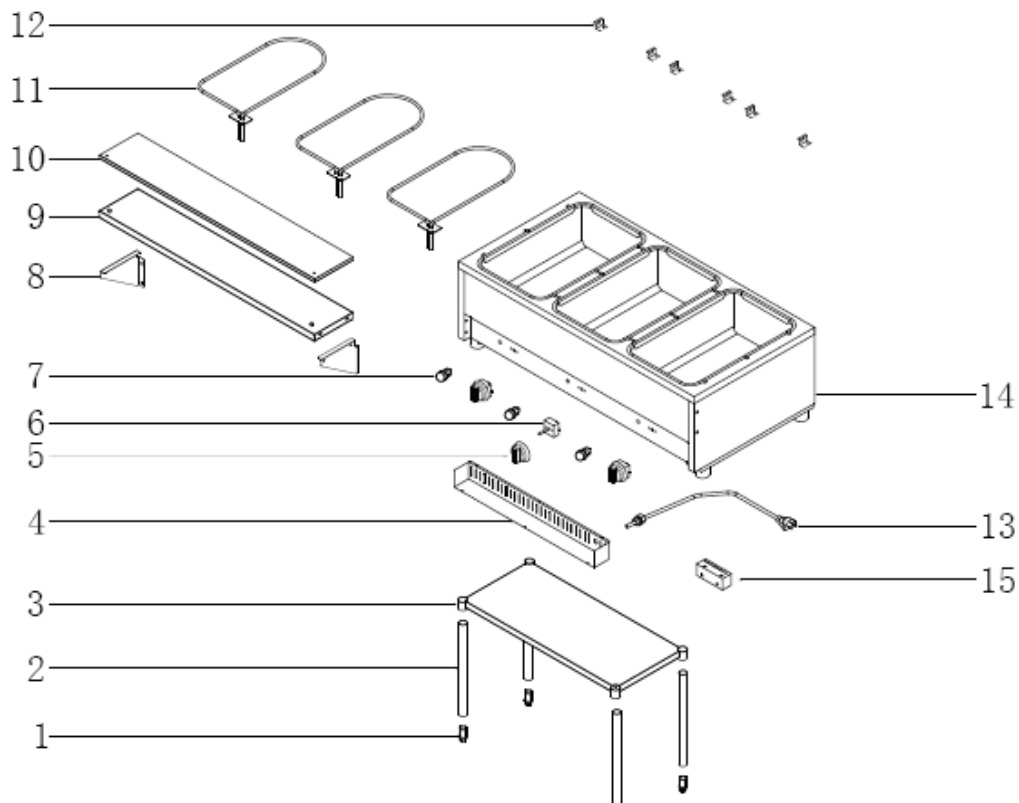
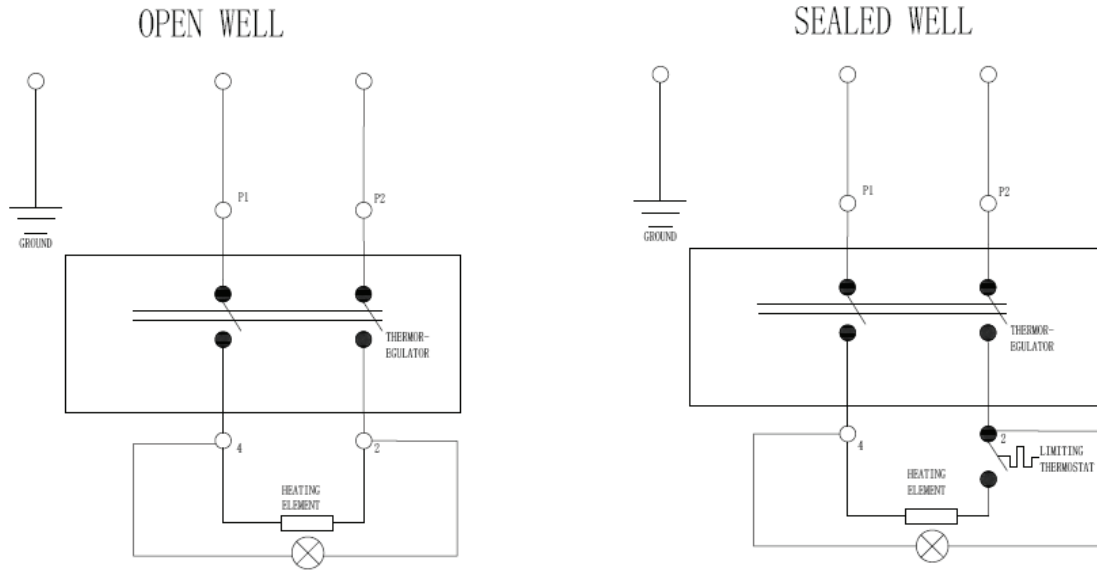

For any service-related Issues, please contact us:
Phone Number: 718-576-6342
Email address: support@koolmore.com



O series(open well) Spare Part List

ITEM		DESCRIPTION
1		ADJUSTABLE FOOT
2		LEG PIPE
3		UNDER SHELF (2) WELL
		UNDER SHELF (3) WELL
		UNDER SHELF (4) WELL
		UNDER SHELF (5) WELL
4		ELECTRICAL BOX (2) WELL
		ELECTRICAL BOX (3) WELL
		ELECTRICAL BOX (4) WELL
		ELECTRICAL BOX (5) WELL
5		THERMOSTAT KNOB
6		THERMOSTAT 120V (Infinite Switch)
		THERMOSTAT 240V (Infinite Switch)
7		INDICATOR LIGHT
8		BRACKET FOR CUTTING BOARD LEFT
		BRACKET FOR CUTTING BOARD RIGHT
9		SHELF FOR CUTTING BOARD (2) WELL
		SHELF FOR CUTTING BOARD (3) WELL
		SHELF FOR CUTTING BOARD (4) WELL
		SHELF FOR CUTTING BOARD (5) WELL
10		POLY CUTTING BOARD (2) WELL
		POLY CUTTING BOARD (3) WELL
		POLY CUTTING BOARD (4) WELL
		POLY CUTTING BOARD (5) WELL
11		HEATING ELEMENT 500W 120v
		HEATING ELEMENT 1000W 240
12		HEATING ELEMENT CLIP
13		CORD AND STRAIN RELIEF 5-15P (120v)
		CORD AND STRAIN RELIEF 5-20P (120v)
		CORD AND STRAIN RELIEF 6-20P (240v)
		CORD AND STRAIN RELIEF 6-30P (240V)
14		BODY
15		TERMINAL BLOCK

For any service-related Issues, please contact us:

Phone Number: 718-576-6342

Email address: support@koolmore.com

S Series (sealed well) Exploded Views

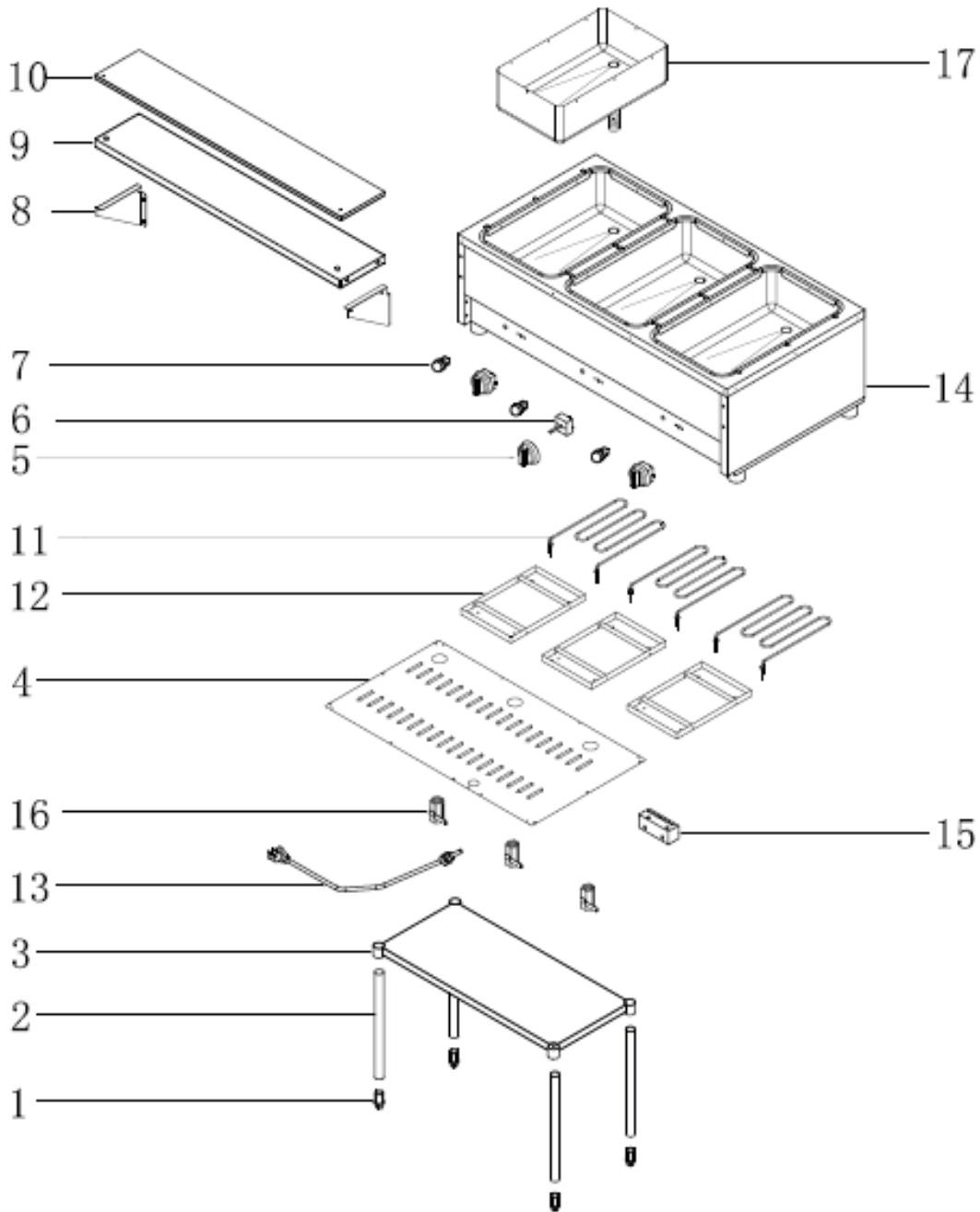

For any service-related Issues, please contact us:
Phone Number: 718-576-6342
Email address: support@koolmore.com



S/SO/SD Series (sealed well)

ITEM		DESCRIPTION
1		ADJUSTABLE FOOT
2		LEG PIPE
3		UNDER SHELF (2) WELL
		UNDER SHELF (3) WELL
		UNDER SHELF (4) WELL
		UNDER SHELF (5) WELL
4		ELECTRICAL BOX (2) WELL
		ELECTRICAL BOX (3) WELL
		ELECTRICAL BOX (4) WELL
		ELECTRICAL BOX (5) WELL
5		THERMOSTAT KNOB
6		THERMOSTAT 120V (Infinite Switch)
		THERMOSTAT 240V (Infinite Switch)
7		INDICATOR LIGHT
8		BRACKET FOR CUTTING BOARD LEFT
		BRACKET FOR CUTTING BOARD RIGHT
9		SHELF FOR CUTTING BOARD (2) WELL
		SHELF FOR CUTTING BOARD (3) WELL
		SHELF FOR CUTTING BOARD (4) WELL
		SHELF FOR CUTTING BOARD (5) WELL
10		POLY CUTTING BOARD (2) WELL
		POLY CUTTING BOARD (3) WELL
		POLY CUTTING BOARD (4) WELL
		POLY CUTTING BOARD (5) WELL
11		HEATING ELEMENT 640 120v
		HEATING ELEMENT 1100W 240
12		HEATING ELEMENT CLIP
13		CORD AND STRAIN RELIEF 5-15P (120v)
		CORD AND STRAIN RELIEF 5-20P (120v)
		CORD AND STRAIN RELIEF 6-20P (240v)
		CORD AND STRAIN RELIEF 6-30P (240V)
14		BODY
15		TERMINAL BLOCK
16		VALVE
17		BOWL