



SPEC SHEET

KoolMore 84 in. 18-Gauge 2-Compartment Commercial Sink with Backsplash and 24 in. Dual Drainboards, Bowl dimensions 18"x24"x14" in Stainless-Steel

Model: KM-SB182414-24B3

FEATURES

- Two 24-inch drainboards for efficient water drainage.
- Adjustable bullet feet for stability and support.
- Constructed from high-quality 304 type 18 gauge stainless steel for durability, rust resistance, and easy upkeep.
- NSF Certified: Meets high standards for sanitation and food safety.
- Hygienic Construction: Seamless stainless steel design for easy cleaning and hygiene.
- Corrosion Resistance: Maintains appearance over time with a corrosion-resistant finish.
- Eco-Friendly: Uses environmentally sustainable materials and manufacturing processes.
- Large Capacity: Designed to handle diverse kitchen tasks efficiently.
- Installation Options: Includes a wall-mounted option for space-saving in busy kitchens.
- Ergonomic Design: Enhances comfort and operational efficiency for kitchen staff.



CLOSE UP IMAGES



TECHNICAL SPECS

Dimensions

Length	84
Width	30
Height	43.2
Weight (lbs)	77
DxWxH of Bowl 1	18"x24"x14"
DxWxH of Bowl 2	18"x24"x14"
Space Between Basins	1.2"
Height From Floor to Bottom of Basin	19.44
Height From Floor to Top of Basin	33.46
Legs Height	18.11
Left Drainboard Length	24
Right Drainboard Length	24
Backsplash Size	9.72

Features & Materials

Exterior Material	stainless steel
Color Finish	silver gray
Drain Included	Yes
Number of Basins	2
Angle of Downward Incline in Basin	2 degrees
Angle of Downward Incline of Dashboard	6 degrees
Legs Adjustable	Yes

Certifications

Certifications	NSF
----------------	-----

Plan View

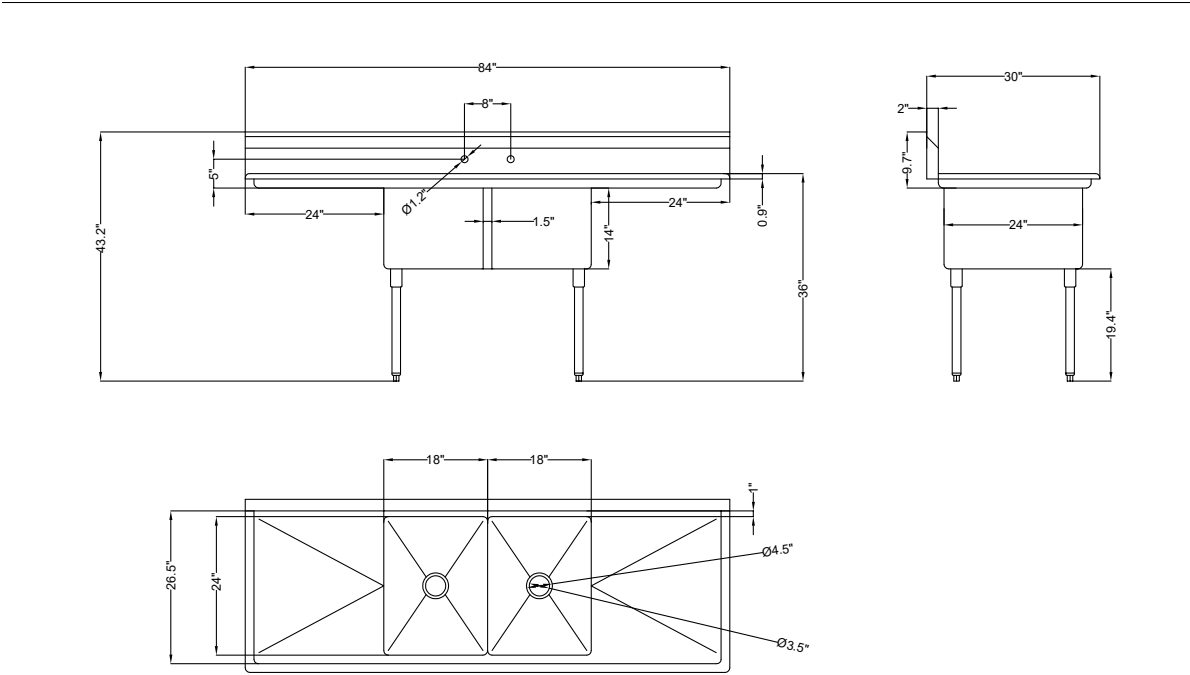

706 Eastern Parkway STE 1G, Brooklyn NY 11213
718-576-6342
info@koolmore.com