



USER MANUAL

WARMING SHELVES

KoolMore Take Out Warmer Shelves and Touch Screen

Models: KM-WSC-T2, KM-WSC-T3, KM-WSC-T4, KM-WSC-T5

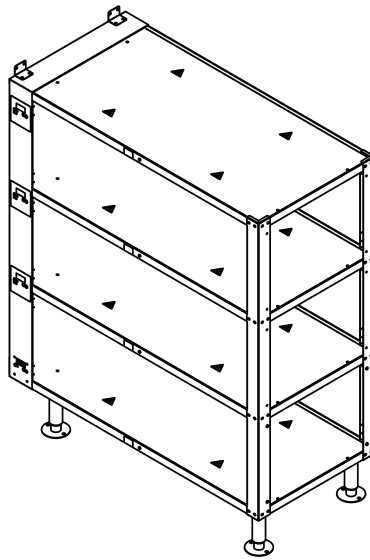

Before using, please read the operating instructions carefully to ensure proper application and achieve satisfactory results.

For any service-related issues, please contact us:



718-576-6342



support@koolmore.com

706 Eastern Parkway STE 1G Brooklyn NY 11213

***Stay informed with the latest information
for your KoolMore KeepWarm Appliance.***

**If you need any assistance or have questions, our customer
support team is here to help.**

SAFETY

Standard Features and Safety Information:

Standard Feature Overview:

The solution is ideal for handling pick-up, third-party delivery, or any food-to-go situation.

The shelves are 20" (508 mm) deep and 39" (991 mm) wide, with a 13" (330 mm) clearance on each shelf, accommodating pizza boxes and bags easily.

Features button controls with digital readouts to indicate separate heat and timer settings for each shelf.

Units come with shelves that have heated bases, thermostatically controlled, and framed with stainless steel.

Power cords are designed to recess into the bottom shelf at a 45-degree angle for snug wall placement.

The design includes optional side and back panels per shelf for customizable configurations and pass-through capabilities. This allows some panels to be removed for single-sided access or for fitting against a wall with a built-in appearance.

Units come with side wall anchor brackets for improved stability, adjustable flanged feet (6" or 152 mm) that can be secured to the floor, and a recessed cord and plug (6' or 1829 mm).

Warning and Safety Instructions:

The heated take-out units are designed for holding a significant amount of packaged, hot food items for up to 30 minutes. They accommodate various carry-out and delivery bags.

These units are the result of rigorous research, testing, and are chosen for maximum durability, appealing look, and optimal performance, with inspections conducted before shipping.

The manual includes detailed installation, safety, and operating instructions for the Heated Shelves. It is crucial that all instructions, operating, and safety directions provided in the manual are followed.

Safety-related content in the manual is marked with specific symbols to highlight the importance of the information, such as "WARNING" for potential serious injuries, "CAUTION" for possible minor or moderate injuries, and "NOTICE" for practices not associated with personal injury.

Warning - Electrical Shock Hazard:

Connect the unit only to a properly grounded electrical receptacle that matches the unit's voltage, size, and plug configuration. If there is a mismatch, seek assistance from a qualified electrician.

Before cleaning, adjusting, or maintenance, turn off the unit, disconnect the power cord, and let the unit cool.

The unit is not designed to be waterproof. Do not use it if it has been submerged or saturated with water.

Notice - Fire Hazard:

Avoid using harsh chemicals, such as bleach, oven cleaners, or flammable solutions to clean this unit.

Improper installation could result in the unit tipping over, leading to injury or damage.

Ensure food is heated to the proper temperature before placing it in the unit to prevent health risks. This unit is intended solely for holding preheated food.

Additional Notices:

The unit should be operated indoors with a minimum ambient temperature of 70°F (21°C).

Do not attempt to clean the unit while it is energized or hot.

Do not use steam cleaning or excessive water when cleaning the unit.

The warranty does not cover damage resulting from improper servicing or temperature misuse.

It is the user's responsibility to ensure that food is kept and served at safe temperatures.

Ensure all operators are fully trained on the safe and proper use of the unit.

This equipment is not suitable for use by children or individuals with reduced physical, sensory, or mental capabilities. Proper supervision is required to prevent access by children.

Warnings:

The unit is not designed for "jet-proof" cleaning methods. Avoid using jet-clean sprays.

If the power cord is frayed or damaged, stop using the unit.

Do not attempt to repair or replace a damaged power cord yourself. This must be done by a qualified technician.

Prevent liquid spills on the unit to avoid malfunctions or safety hazards.

Caution:

Be cautious with hot exterior surfaces of the unit; avoid direct contact.

Ensure the unit is placed in a stable and level location capable of supporting its weight, and never lay it on its front or back to prevent damage.

Utilize only non-abrasive cleaning agents and cloths to maintain the unit's finish and prevent soil buildup.

Notices:

The unit should be serviced by qualified personnel to avoid electric shock or burns.

Utilizing genuine replacement parts is essential. Substituting with aftermarket or non-original parts may compromise the unit's safety features and void warranties.

INSTALLATION

Installation Instructions for Heated Shelves:

The unit arrives mostly pre-assembled. Handle with care when unpacking to avoid damage. Ensure the unit operates indoors with a minimum ambient temperature of 70°F (21°C) as it is not weatherproof.

Warnings:

Keep the unit at least 1" (25 mm) away from combustible materials to prevent fire hazards. After unpacking, promptly complete the online warranty registration to avoid delays in coverage.

Installation Steps:

1. Remove all packing materials from the unit.
2. Do not position the unit on its front or back to prevent damage.
3. Install the legs on the unit's side with caution, requiring two people. Tighten the legs securely but avoid over-tightening.
4. Place the unit in a location with a constant ambient temperature above 70°F (21°C), away from drafts and active air movements.
5. Ensure the floor is level for floor units, and secure the unit with wall brackets or floor flanges if needed. This will prevent tipping, which could result in injury or damage.
6. For wall-mounted units, use the provided wall brackets and follow the "Wall Bracket Installation" guide. For floor-mounted units with flanges, refer to the "Floor Flange Installation" guide within the manual.

Floor Flange Installation Procedure:

To securely attach a unit to the floor using the provided floor flanges, follow these steps:

1. Confirm that the chosen installation spot is suitable for anchoring the unit.
2. Select the correct fasteners (which are not included with the unit) based on the type of flooring or countertop material where the unit will be installed.
3. Attach the unit to the floor or countertop by driving the selected fasteners through the floor flanges.

Note:

The floor flanges are designed to be adjustable, which allows for the unit to be leveled prior to being fastened into place on the floor or countertop.

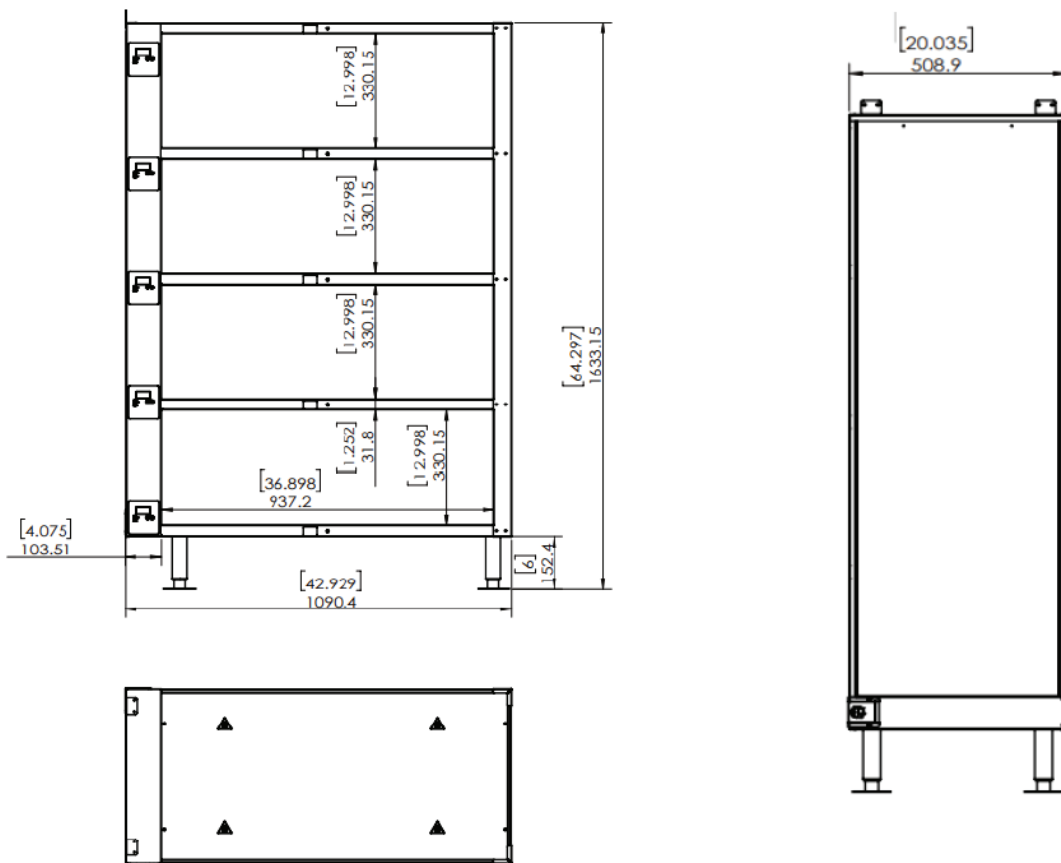

Digital Separate Control Unit Wire Diagram

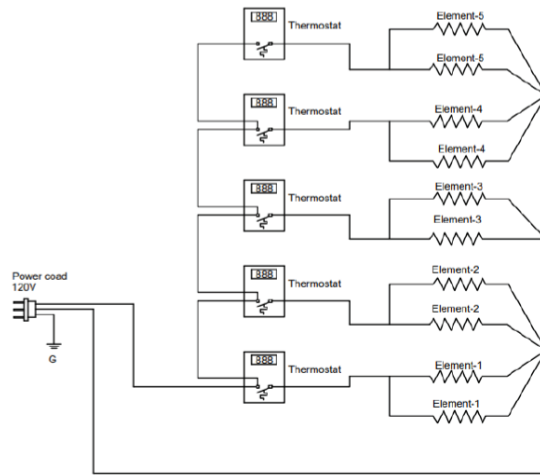

Digital Separate Control Unit Exploded View

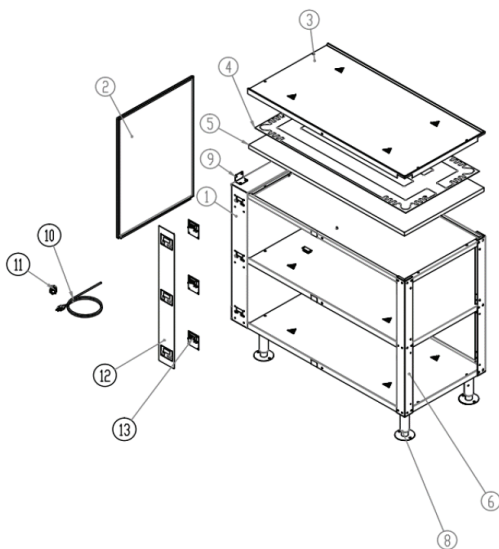

NO	Item	Description	Qty
1	ENTOSD-001	Electric control cabinet	1
2	ENTOSD-002	Door	1
3	ENTOSD-003	Shelf Top Assembly	2-5
4	ENTOSD-004	Heating Element	2-5
5	ENTOSD-005	Insulation	2-5
6	ENTOSD-006	Left column	1
7	ENTOSD-007	Right column	1
8	ENTOSD-008	SS Leg, 6"	4
9	ENTOSD-009	Bracket	2
10	ENTOSD-017	Power cord with plug	1
11	ENTOSD-018	Cord grip	1
12	ENTOSD-019	control panel	1
13	ENTOSD-020	Digital display thermostat	2-5

Touchscreen Control Unit Wire Diagram

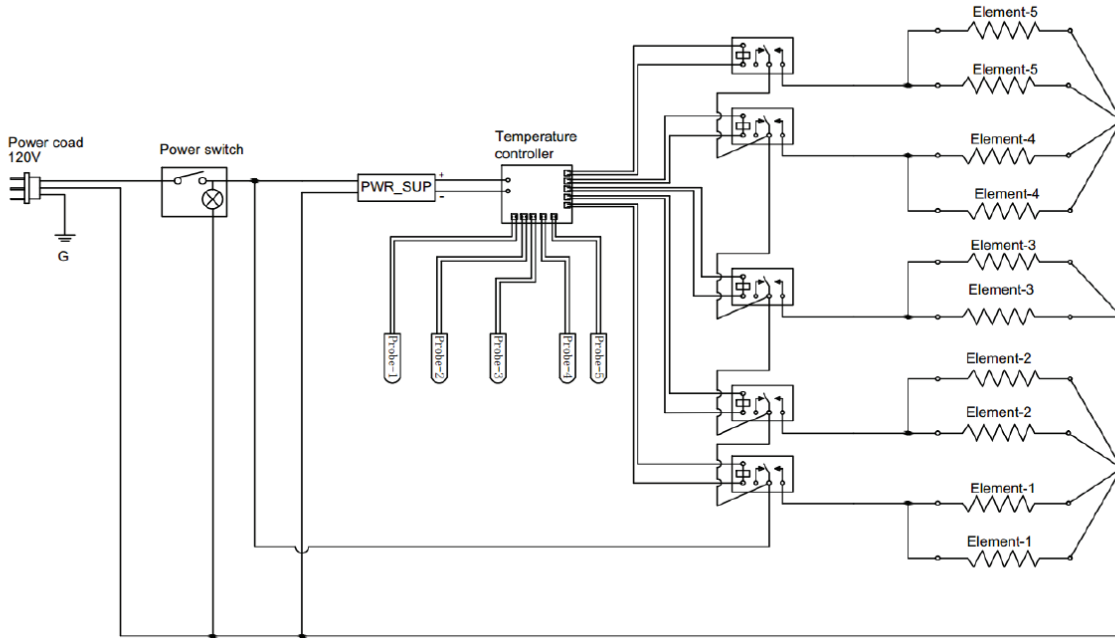

Touchscreen Control Unit Exploded View

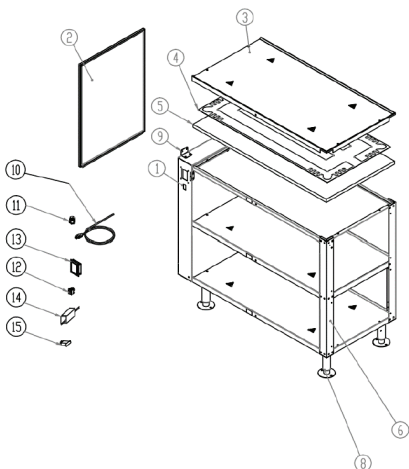

NO	Item	Description	Qty
1	ENTOST-001	Electric control cabinet	1
2	ENTOST-002	Door	1
3	ENTOST-003	Shelf top assembly	5-Feb
4	ENTOST-004	Heating element	5-Feb
5	ENTOST-005	Insulation	5-Feb
6	ENTOST-006	Post	2
7	ENTOST-008	Leg, 6"	4
8	ENTOST-009	Bracket	2
9	ENTOST-010	Power cord w/Plug	1
10	ENTOST-011	Cord Grip	1
11	ENTOST-012	Rocker Switch, Power	1
12	ENTOST-013	Touchscreen controller	1
13	ENTOST-014	LED Driver	1
14	ENTOST-015	Relay	5-Feb

TROUBLESHOOTING

Service Warning: The unit must be serviced by qualified personnel only. Attempts to service the unit by unqualified personnel may result in electric shock or burns.

Electric Shock Hazard: Before performing any cleaning, adjustments, or maintenance, ensure that the power switch is turned off, the power cord is unplugged, and the unit is allowed to cool down to prevent electric shock.

Symptom	Probable Cause	Corrective Action
Shelf too hot	Air temperature is set too high.	Adjust the temperature to a lower setting.
	Unit connected to incorrect power supply.	Contact an Authorized Service Agent for assistance.
	Internal thermostat defective.	Contact an Authorized Service Agent for assistance.
Shelf not hot enough	Unit not allowed enough time to preheat.	Allow unit 15-20 minutes to reach operating temperature.
	Air temperature is set too low.	Adjust the temperature to a higher setting.
	Internal thermostat defective.	Contact an Authorized Service Agent for assistance.
Unit not working at all	Unit not plugged in.	Plug unit into proper power supply.
	Unit not turned on.	Move Power I/O (on/off) switch to the I (on) position.
	Circuit breaker tripped.	Reset circuit breaker.
	Power I/O (on/off) switch	Contact an Authorized Service Agent for assistance.
	Internal thermostat	Contact an Authorized Service Agent for assistance.
	Heating element burned	Contact an Authorized Service Agent for assistance.



WARRANTY

LIMITED WARRANTY

Koolmore Supply, Inc. extends a limited warranty to the original purchaser, guaranteeing that this Koolmore product is free from manufacturing defects in material or workmanship for one year from the date of purchase.

Should you discover any such defect within the warranty period, Koolmore Supply, Inc., reserves the right to repair or replace the product without charge, or to cover the cost of replacement parts and repair labor needed to correct defects present at the time of purchase or resulting from regular usage, when the appliance has been installed, operated, and maintained as per the instructions provided.

At its sole discretion, Koolmore Supply Inc. may decide to replace the product. In such an event, your replacement appliance will carry the warranty for the remaining term of the original unit's warranty period.

This warranty is valid exclusively to the original purchaser of the product and only applicable within the United States. The warranty commences from the date of original consumer purchase. Proof of the original purchase date will be required to obtain service under this warranty.

Under this limited warranty, your sole and exclusive remedy will be product repair, as outlined above. All services must be provided by a Koolmore-designated service company.

To claim warranty or request repair service:

Email support@koolmore.com. Please include your name, address, phone number, warranty repair request, and a copy of your proof of purchase receipt. Alternatively, visit koolmore.com and use the contact us page. A Koolmore customer service representative will promptly arrange service for your appliance.

We thank you for choosing Koolmore.

WARRANTY EXCLUSIONS

This limited warranty will not cover:

1. Failure of the product to perform during power failures or interruptions, or due to inadequate electrical service.
2. Damage incurred during transportation or handling.
3. Damage caused by accidents, vermin, lightning, winds, fire, floods, or acts of God.
4. Damage resulting from accidents, alterations, misuse, abuse, improper installation, repair, or maintenance. This includes using any external device that alters or converts the voltage or frequency of electricity.
5. Unauthorized product modifications, repairs by unauthorized centers, or use of non-approved replacement parts.
6. Abnormal cleaning and maintenance not aligned with the user's manual.
7. Use of incompatible accessories or components.
8. Any costs associated with repairs or replacements under these excluded circumstances shall be the responsibility of the consumer.

