



SPEED QUEEN® ON-PREMISES LAUNDRY SOLUTIONS  
**Rear Control Front Load Washer**

LFNE5RSP115TW01, LFN50RSP115TW01

**Front Load Washers**

Designed to be everything you never thought a washing machine could be, the revolutionary Speed Queen® front load washers feature an unprecedented amount of cutting-edge innovations to help you improve performance and minimize costs..

- Revolutionary balancing technology redistributes unbalanced load for uninterrupted wash cycles.

- Increase spin speed extracts 440 G-Force to maximize moisture removal and lower drying times.
- 20% increase in capacity with improved water usage to decrease operating costs.
- Redesigned 4-compartment soap dispenser for simplified use and cleaning.



**Electronic Control**

Speed Queen® washers with Electronic controls are designed for durability and are easy to operate with intuitive selection buttons and cycle status indicator lights. This control option features a time-remaining display, six preset cycle buttons, cycle adjustability for temperature, load size and soil levels along with additional cycle enhancer options for a pre-wash or second rinse cycle.



**Mechanical Control**

Speed Queen® washers with Mechanical controls are designed for durability and are easy to operate with a multi-cycle timer knob and extra rinse switch.

# Rear Control Front Load Washer

Specifications		
Model/ Control Option	Electronic (EH)	LFNE5RSP115TW01
	Mechanical (MH)	LFN50RSP115TW01
Control Location	Rear	
Capacity - lb (kg)	21.5 (10)	
Cylinder Volume - cu. ft. (liters)	3.42 (96.8)	
Overall Width - in (mm)	26.875 (683)	
Overall Depth - in (mm)	27.73 (704)	
Overall Height - in (mm)	43 (1092)	
Spin Speed G-Force -RPM	440 (1200)	
Motor Power Consumption - hp (kw) Variable Speed Induction	0.9 (0.67)	
Water Consumption Per Cycle -g (l)	13.68 (51.8)	
IWF (Water Factor)	4.0 (0.53)	
IMEF (Modified Energy Factor)	2.20 (62.3)	
Available Water Temperatures	3	
*Available Cycles	Heavy Duty, Normal Eco, Perm Press, Delicate, Rinse & Spin, Spin Only	
Water Pressure -PSI (Bar)	20-120 (1.4/8.3)	
Cycle Indicator Lights	Yes	
Cylinder Finish	Stainless Steel	
Available Colors	White	
Door Type (Solid/Window)	Window	
Available Electrical Requirements - Voltage/Hz/Ph - Circuit Amperage	120/60/1 - 15	
Shipping Dimensions Approx. - in (mm)	Width	30 (762)
	Depth	34 (864)
	Height	44.5 (1130)
Net Weight - lb (kg)	260 (118)	
Shipping Weight - lb (kg)	270 (122)	
Agency Approvals	cULus	

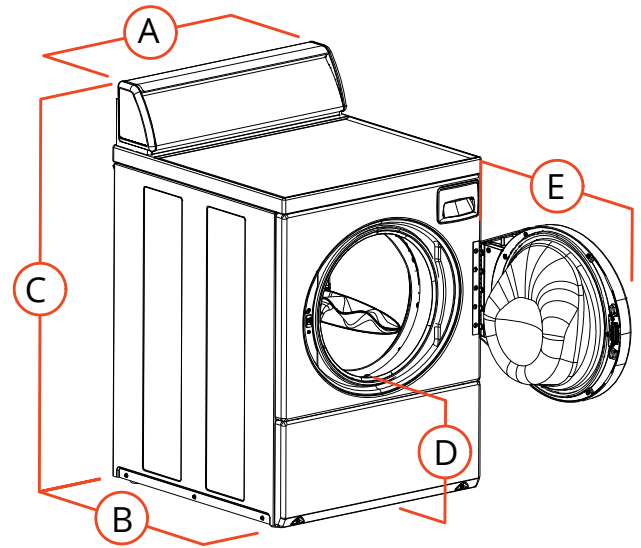

A. Overall Width - in (mm)	26.875 (683)
B. Overall Depth - in (mm)	27.73 (704)
C. Overall Height - in (mm)	43 (1092)
D. Floor To Door Opening -in (mm)	14.6 (371)
E. Door Swing - in (mm)	24.06 (611)

ADA Compliant

Note: Not all options are available for all models. Refer to the price list for the available models and options.

\* Information shown applies to highest end control available.

For the most accurate information, the installation guide should be used for all design and construction purposes. Due to continuous product improvements, design and specifications subject to change without notice. The quality management systems at Alliance Laundry Systems are registered to ISO 9001.