

LG SIGNATURE

ENGLISH

ESPAÑOL

OWNER'S MANUAL GAS RANGE

Read this owner's manual thoroughly before operating the appliance and keep it handy for reference at all times.

WARNING

If the information in this manual is not followed exactly, a fire or explosion may result causing property damage, personal injury or death.

- **Do not store or use gasoline or other flammable vapors and liquids in the vicinity of this or any other appliance.**
- **WHAT TO DO IF YOU SMELL GAS**
 - Do not try to light any appliance.
 - Do not touch any electrical switch.
 - Do not use any phone in your building.
 - Immediately call your gas supplier from a neighbor's phone. Follow the gas supplier's instructions.
 - If you cannot reach your gas supplier, call the fire department.
- Installation and service must be performed by a qualified installer, service agency, or the gas supplier.

WARNING

Never Operate the Top Surface Cooking Section of this Appliance Unattended

- Failure to follow this warning statement could result in fire, explosion, or burn hazard that could cause property damage, personal injury, or death.
- If a fire should occur, keep away from the appliance and immediately call your fire department.
- **DO NOT ATTEMPT TO EXTINGUISH AN OIL/GREASE FIRE WITH WATER.**

LPGU6319Y



MFL69282823_00

www.LGSIGNATURE.com

Copyright © 2026 LG Electronics. All Rights Reserved.

TABLE OF CONTENTS

4 IMPORTANT SAFETY INSTRUCTIONS

13 PRODUCT OVERVIEW

- 13 Parts
- 13 Accessories

14 INSTALLATION

- 14 Installation Overview
- 14 Product Specifications
- 15 Before Installing the Range
- 17 Ventilation Requirement
- 17 Proper Location
- 20 Gas Supply
- 20 Installing the Range
- 24 Connecting the Range to Gas
- 25 Electrical Connections
- 25 Sealing the Openings
- 26 Engaging the Anti-tip Device
- 26 Test Run
- 26 Checking Ignition of the Surface Burners
- 27 Adjusting the Surface Burner to the Low Flame (Simmer) Setting

28 OPERATION

- 28 Control Panel Overview
- 30 Getting Started
- 30 Changing Oven Settings
 - 30 Settings
 - 30 Wi-Fi
 - 31 Remote Start
 - 31 Control Lock
 - 31 Display
 - 31 Brightness
 - 32 Clock Themes
 - 32 Volume
 - 32 Language Selection
 - 32 Date & Time
 - 32 Temperature Unit
 - 33 Sabbath Mode
 - 33 Start Screen
 - 33 Temperature Adjustment

- 34 Convection Auto Conversion
- 34 Preheat End Light
- 34 Smart Diagnosis™
- 34 Factory Reset
- 34 Open Source License
- 35 Using the Cooktop
 - 35 Gas Cooktop Module
- 35 The Gas Surface Burners
 - 35 Before Use
 - 36 Using the Gas Surface Burners
 - 36 Using the Knob Lock
 - 37 Setting the Flame Size
 - 37 In Case of Power Failure
 - 37 Cookware for Gas Burners
 - 37 Using Stove-Top Grills
- 38 Using the Oven
 - 38 Before Using the Oven
 - 38 In Case of Power Failure
 - 38 Oven Vent
 - 38 Using Oven Racks
 - 39 Accessories
 - 39 Oven Cooling
 - 39 Timer
 - 40 Bake
 - 41 Convection Modes
 - 42 Recommended Baking and Roasting Guide
 - 43 Broil
 - 44 Recommended Broiling Guide
 - 45 Warm
 - 46 Keep Warm
 - 46 Air Fry
 - 47 Recommended Air Frying Guide
 - 49 Air Sous-Vide
 - 49 Recommended Air Sous-Vide Guide
 - 50 Air Roast
 - 50 Pizza
 - 50 Dehydrate
 - 50 Crispy Reheat
 - 50 Frozen Meal
 - 51 Proof
 - 51 Probe
 - 54 My Recipe
 - 54 Recent Cook
 - 55 Remote Start
 - 55 Auto Cook Mode
 - 56 Auto Cook Guide

75 SMART FUNCTIONS

- 75 LG ThinQ Application
- 76 Smart Diagnosis™ Feature
- 77 Open Source Software Notice Information
- 77 Radio Equipment Specifications
- 77 FCC Notice
- 77 FCC RF Radiation Exposure Statement

78 MAINTENANCE

- 78 Control Panel
- 78 Gas Surface Burners
- 79 Burner Grates
- 79 Gas Cooktop Surface
- 80 Exterior
- 81 Front Manifold Panel and Knobs
- 82 EasyClean®
- 84 Self Clean
- 86 Oven Air Vents
- 86 Adjusting Oven Door Handle
- 87 Removing and Replacing the Lift-Off Oven Doors

88 TROUBLESHOOTING

- 88 FAQs
- 90 Before Calling for Service

94 LIMITED WARRANTY

- 94 USA
 - 94 TERMS AND CONDITIONS
 - 94 THIS LIMITED WARRANTY DOES NOT COVER:
 - 95 PROCEDURE FOR RESOLVING DISPUTES:
- 97 Not Covered by Warranty

IMPORTANT SAFETY INSTRUCTIONS

Read and follow all instructions when using the range to prevent the risk of fire, electric shock, personal injury, or damage. This guide does not cover all possible conditions that may occur. Always contact your service agent or manufacturer about problems that you do not understand.

Download this owner's manual at: www.LGSIGNATURE.com

 This is the safety alert symbol. This symbol alerts you to potential hazards that can result in property damage and/or serious bodily harm or death. All safety messages will follow the safety alert symbol and either the word **WARNING** or **CAUTION**. These words mean:

 **WARNING** - Indicates a hazardous situation which, if not avoided, could result in death or serious injury.

 **CAUTION** - Indicates a hazardous situation which, if not avoided, could result in minor or moderate injury.

ANTI-TIP DEVICE

WARNING

- **TO REDUCE THE RISK OF TIPPING, THE APPLIANCE MUST BE SECURED BY A PROPERLY INSTALLED ANTI-TIP DEVICE. TO CHECK IF THE DEVICE IS INSTALLED PROPERLY, VERIFY THAT THE ANTI-TIP DEVICE IS ENGAGED, OR GRASP THE TOP REAR EDGE OF THE RANGE BACK GUARD AND CAREFULLY ATTEMPT TO TILT IT FORWARD.** Refer to the installation section for instructions.
 - A child or adult can tip the range and be killed.
 - Install the anti-tip device to the structure and/or the range. Verify the anti-tip device has been properly installed and engaged following the instructions on the anti-tip bracket template.
 - Engage the range to the anti-tip device following the instructions on the anti-tip bracket template. Ensure the anti-tip device is re-engaged when the range is moved by following the instruction on the anti-tip bracket template.
 - Re-engage the anti-tip device if the range is moved. Do not operate the range without the anti-tip device in place and engaged.
 - See installation instructions for details.
 - Failure to do so can result in death or serious burns to children or adults.
- Never remove the oven legs. The range will not be secured to the anti-tip bracket if the legs are removed.
 - Do not step or sit on the oven door. The range could be tipped and injury might result from spilled hot liquid, food, or the range itself.
 - Do not rest large, heavy items such as whole turkeys on the open oven door. The range could tip forward and cause injury.
 - Reengage the anti-tip device after pulling the range out for cleaning, service, or any other reason.
 - Failure to follow these instructions can result in death or serious burns to children or adults.

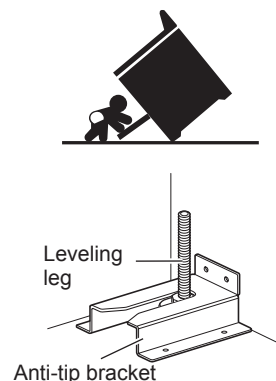

INSTALLATION SAFETY PRECAUTIONS

Have the installer show you the location of the range gas shut-off valve and how to shut it off if necessary.

WARNING

- Make sure the range is properly installed and grounded by a qualified installer, according to the installation instructions. Any adjustment and service should be performed only by qualified gas range installers or service technicians.
- Make sure the range is properly adjusted by a qualified service technician or installer for the type of gas (natural or LP) that is to be used. The range can be converted for use with either type of gas. See the installation instructions.
- These adjustments must be done by a qualified service technician according to the manufacturer's instructions and all codes and requirements of the authority having jurisdiction. Failure to follow these instructions could result in serious injury or property damage. The qualified agency performing these adjustments assumes responsibility for the conversion.
- Disconnect the electrical supply before servicing the appliance.
- Never use the appliance door as a step stool or seat, as this may result in tipping of the appliance and serious injuries.
- This product should not be installed below ventilation type hood systems that direct air in a downward direction.
Doing so may cause ignition and combustion problems with the cooktop resulting in personal injury and may affect the cooking performance of the unit.
- To prevent fire hazard or electrical shock, do not use an adapter plug or an extension cord, or remove the grounding prong from the electrical power cord. Failure to follow this warning can cause serious injury, fire or death.
- To prevent poor air circulation, place the range out of the kitchen traffic path and out of drafty locations.
- Do not attempt to repair or replace any part of the range unless it is specifically mentioned in this manual. All other services should be referred to a qualified technician.
- Make sure that all packaging materials are removed from the range before operating it to prevent fire or smoke damage should the packaging material ignite.
- After using the range for an extended period of time high floor temperatures may result. Many floor coverings will not withstand this kind of use.
- Never install the range over vinyl tile or linoleum that cannot withstand such type of use. Never install it directly over interior kitchen carpeting.

SAFETY PRECAUTIONS

Gas appliances can cause minor exposure to four of these substances, namely benzene, carbon monoxide, formaldehyde and soot, caused primarily by the imperfect combustion of natural or LP gas. Correctly adjusted burners, indicated by a bluish rather than a yellow flame, will minimize imperfect combustion. Exposure to these substances can be minimized by opening windows or using a ventilation fan or hood.

- **DO NOT TOUCH HEATING ELEMENTS OR INTERIOR SURFACES OF OVEN.** Heating elements may be hot even though they are dark in color. Interior surfaces of an oven become hot enough to cause burns. During and after use, do not touch or let clothing or other flammable materials contact heating elements or interior surfaces of oven until they have had sufficient time to cool. Other surfaces, such as oven vent openings and surfaces near these openings, oven doors, and windows of oven doors, also get hot and may cause burns if not cooled.

- **Use care when opening door.** The hot air and steam that escape can cause burns to hands, face and eyes. Let hot air or steam escape from the oven before removing or replacing food in the oven.
- Do not repair or replace any part of the appliance unless specifically recommended in the manual. All other servicing should be performed by a qualified technician.
- Do not use harsh etching, abrasive cleaners or sharp metal scrapers to clean the oven door glass since they can scratch the surface. Scratches may cause the glass to shatter.

 **WARNING**

If the door glass, surface, or oven heating unit of the range are damaged, discontinue use of the range and call for service.

- Do not use plastic to cover food. Use foil or oven-safe lids only.
- Do not allow anyone to climb, stand or hang on the door or cooktop. They could damage the range and even tip it over, causing severe personal injury.
- Do not line the oven walls, racks, bottom, or any other part of the oven with aluminum foil or any other material. Doing so will disrupt heat distribution, produce poor baking results and cause permanent damage to the oven interior (aluminum foil will melt to the interior surface of the oven)
- Never attempt to dry a pet in the oven.
- **Never use your appliance for warming or heating the room.**
- Always use pot holders or oven mitts when removing food from the oven or the surface element. Cookware will be hot. **Use only dry pot holders.** Moist or damp pot holders on hot surfaces may result in burns from steam. Do not let the pot holder touch hot heating elements. Do not use a towel or other bulky cloth to remove food.
- **Do not heat unopened food containers.** Pressure in the containers may cause them to burst which may result in injury.
- Large scratches or impacts to glass doors can lead to broken or shattered glass.
- Leak testing of the appliance must be conducted according to the manufacturer's instructions.
- To eliminate the risk of burns or fire caused by reaching over heated surface units, cabinet storage space located above the surface units should be avoided. If cabinet storage is to be provided, the risk can be reduced by installing a range hood that projects horizontally a minimum of 5 inches beyond the bottom of the cabinets.

 **WARNING**

- **NEVER** cover any slots, holes or passages in the oven bottom or cover an entire rack with materials such as aluminum foil. Doing so blocks air flow through the oven and may cause carbon monoxide poisoning. Aluminum foil linings may also trap heat, causing a fire hazard.
- **NEVER** use this appliance as a space heater to heat or warm the room. Doing so may result in carbon monoxide poisoning and overheating of the oven.
- Gas leaks may occur in the system and result in a serious hazard. Gas leaks may not be detected by smell alone. Gas suppliers recommend you purchase and install a UL/CSA approved gas detector. Install and use in accordance with the gas detector manufacturer's instructions.
- To prevent staining or discoloration, clean appliance after each use.
- Do not attempt to open or close the door or operate the oven until the door is properly installed.
- Never place fingers between the hinge and front oven frame. Hinge arms are spring mounted. If accidentally hit, the hinge will slam shut against the oven frame and injure your fingers.

⚠ CAUTION

- Wear gloves when cleaning the range to avoid injury or burns.
- Do not use the oven for storing food or cookware.
- To prevent damage to the oven door, do not attempt to open the door when Lock is displayed.
- Do not stand or place excessive weight on an open door. This could tip the range, break the door, or injure the user.
- Do not use delayed baking for highly perishable foods such as dairy products, pork, poultry, or seafood.

FLAMMABLE MATERIALS**⚠ WARNING**

Be certain that all packing materials are removed from the appliance before operating. Keep plastic, clothes, paper, and other flammable materials away from parts of the appliance that may become hot.

- Do not store or use flammable material in the oven or near or on the cooktop. Flammable materials include paper, plastic, pot holders, linens, wall coverings, curtains, and gasoline or other flammable vapors and liquids such as grease or cooking oil. These materials can be ignited when the oven and cooktop are in use.
- **Wear proper apparel.** Do not wear loose-fitting or hanging garments, which may ignite if they contact hot surfaces, and cause severe burns.
- Do not use the oven for drying clothes. Only use the oven for its intended purpose.
- If a cabinet storage is provided directly above cooking surface, place items that are not frequently used and can be safely stored in an area subjected to heat. Temperatures may be unsafe for volatile items such as flammable liquids, cleaners or aerosol sprays.

ELECTRICAL SAFETY**⚠ CAUTION**

- Be certain that all packing materials are removed from the appliance before operating. Keep plastic, clothes, paper, and other flammable materials away from parts of the appliance that may become hot.
- Risk of Electric Shock. If the cord or plug becomes damaged, disconnect the appliance from the power supply and replace only with a cord or plug of the same type.

- Always disconnect power from the appliance before servicing.
- Do not use aluminum foil or any other material to line the oven bottom. Improper installation of these liners may result in a risk of electric shock or fire.
- Do not allow aluminum foil or the temperature probe to contact heating elements.

DEEP FAT FRYER

- Use extreme caution when moving or disposing of hot grease.
- Always heat fat slowly, and watch as it heats.
- If frying combinations of oils and fats, stir them together before heating.
- Use a deep fat thermometer, if possible, to prevent overheating fat beyond the smoking point.
- Use the least possible amount of fat for effective shallow or deep-fat frying. Filling the pan with too much fat can cause spillovers when food is added.

CHILD SAFETY

- Do not leave small children unattended near the oven.

WARNING

Do not leave children alone or unsupervised near the appliance when it is in use or is still hot. Children should never be allowed to sit or stand on any part of the appliance as they could be injured or burned.

CAUTION

Do not store items of interest to children in cabinets above a range or on the back guard of a range – children climbing on the range to reach items could be seriously injured.

- Never let a child hang on the oven door.
- Do not allow children to crawl into the oven.
- Let hot utensils cool in a safe place, out of reach of small children.
- Children should not be allowed to play with controls or other parts of the appliance.

SURFACE BURNERS

WARNING

- Even if the top burner flame goes out, gas is still flowing to the burner until the knob is turned to the **Off** position. If you smell gas, immediately open a window and ventilate the area for five minutes prior to using the burner. Do not leave the burners on unattended.

WARNING

- **Use proper pan size.** Do not use pans that are unstable or that can be easily tipped. Select cookware with flat bottoms large enough to cover burners. To avoid spillovers, make sure the cookware is large enough to contain the food properly. This will both save cleaning time and prevent hazardous accumulations of food, since heavy spattering or spillovers left on the range can ignite. Pans should not be larger than 11 in.(280 mm) in diameter. Use of oversized pans may discolor the stainless areas around the cooktop perimeter. Clean discolored areas with stainless steel appliance cleaner. Use pans with handles that can be easily grasped and remain cool.

CAUTION

- Be sure that all surface controls are set in the **Off** position prior to supplying gas to the range.
- Never leave the surface burners unattended at high flame settings. Boilovers may cause smoke and greasy spillovers that may ignite.
- Always turn the knobs to the **Lite** position when igniting the top burners and make sure the burners have ignited.
- Control the top burner flame size so it does not extend beyond the edge of the cookware. Excessive flame is hazardous.
- Only use dry pot holders- moist or damp pot holders on hot surfaces may result in burns from steam. Do not let pot holders come near open flames when lifting cookware. Do not use towels or other bulky cloth items. Use a pot holder.
- If using glass cookware, make sure the cookware is designed for range-top cooking.
- To prevent burns from ignition of flammable materials and spillage, turn cookware handles toward the side or back of the range without extending them over adjacent burners.

 **CAUTION**

- Never leave any items on the cooktop. The hot air from the vent may ignite flammable items and will increase pressure in closed containers, which may cause them to burst.
- Carefully watch foods being fried at a high flame setting.
- Always heat fat slowly, and watch as it heats.
- If frying combinations of oils and fats, stir together before heating.
- Use a deep fat thermometer if possible to prevent fat from heating beyond the smoking point.
- Use the least possible amount of fat for effective shallow or deep fat frying. Filling the pan with too much fat can cause spillovers when food is added.
- Do not cook foods directly on an open flame on the cooktop.
- Foods for frying should be as dry as possible. Frost or moisture on foods can cause hot fat to bubble up and spill over the sides of the pan.
- Never try to move a pan of hot fat, especially a deep fryer. Wait until the fat is cool.
- Do not place plastic items on the cooktop- they may melt if left too close to the vent.
- Keep all plastics away from the surface burners.
- To prevent burns, always be sure that the controls for all burners are in the **Off** position and all grates are cool before attempting to remove them.
- If you smell gas, turn off the gas to the range and call a qualified service technician. Never use an open flame to locate a leak.
- Always turn the knobs to the **Off** position before removing cookware.
- Do not lift the cooktop. Lifting the cooktop can cause damage and improper operation of the range.
- If the range is located near a window, do not hang long curtains that could blow over the surface burners and catch on fire.
- Use care when cleaning the cooktop. The pointed metal ends on the electrodes could cause injury.
- Stand away from the range while frying.
- Keep an eye on foods being fried at high or medium high heat settings.

FOOD PACKAGING AND STORAGE SAFETY INFORMATION

- Always wash your hands carefully with soap and water before and after handling food.
- Keep all work surfaces and utensils clean and disinfected before and after packaging foods.
- Temperature, moisture, acidity, and salt or sugar content of foods can influence the growth of potentially harmful microorganisms in food.
- For safety, vacuum-sealed fresh (perishable) foods should be kept in the "safe zones": cooled to 40°F/4°C or below or heated to 130°F/55°C or above.
- Vacuum-sealed pouches of cooked foods can be quick chilled by submerging them in ice water (half ice/half water) for 30 to 60 minutes and then refrigerated for up to 48 hours or frozen for up to a year.

ENERGY SAVING TIPS

- Multiple-rack cooking saves time and energy. Whenever possible, cook foods requiring the same cooking temperature together in one oven.
- For optimal performance and energy savings, follow the guides for proper rack and pan placements.
- Match the size of the cookware to the amount of food being cooked to save energy when heating. Heating ½ quart of water requires more energy in a 3-quart pot than in a 1-quart pot.
- Match the size of the cooktop burner or element to the size of the cookware in use. Using a large element for a small pan wastes heating energy, and the exposed surface of the element is a burn or fire hazard.
- Reduce energy use by cleaning light oven soils with the Easyclean® feature instead of self-clean.
- Avoid opening the oven door more than necessary during use. This helps the oven maintain temperature, prevents unnecessary heat loss, and saves on energy use.

SAFETY DURING USE

- Do not touch the oven racks while they are hot.
- If a rack must be moved while the oven is hot, do not let the pot holder contact the hot heating element in the oven.
- Use caution with the Timed Cook or Delayed Timed Cook features. Use the automatic timer when cooking cured or frozen meats and most fruits and vegetables. Foods that can easily spoil, such as milk, eggs, fish, meat or poultry, should be chilled in the refrigerator first. Even when chilled, they should not stand in the oven for more than 1 hour before cooking begins, and should be removed promptly when cooking is complete. Eating spoiled food can result in sickness from food poisoning.
- Accessible parts may become hot when the grill is in use.
- Do not place food or cookware on the bottom of the oven cavity. Doing so will cause permanent damage to the oven bottom finish.
- **Do not use water on grease fires.** Should an oven fire occur, leave the oven door closed and turn the oven off. If the fire continues, throw baking soda on the fire or use a fire extinguisher. Do not put water or flour on the fire. Flour may be explosive and water can spread a grease fire and cause personal injury.
- When disposing of the range, cut off the power cord and remove the door.
- Do not make any attempt to operate the electric ignition oven during an electrical power failure.
- Pull the oven rack to the stop-lock position when loading and unloading food from the oven. This helps prevent burns caused by touching hot surfaces of the door and oven walls.
- Do not use the oven if a heating element develops a glowing spot during use or shows other signs of damage. A glowing spot indicates the heating element may fail and present a potential burn, fire, or shock hazard. Turn the oven off immediately and have the heating element replaced by a qualified service technician.
- When using cooking or roasting bags in the oven, follow the manufacturer's directions.

WARNING

- To reduce the risk of burns, do not move this appliance while hot. To reduce the risk of injury due to tipping of the appliance, verify the reinstallation of this appliance into the anti-tip device provided after returning the appliance to the original installed position.

SAFETY WHEN CLEANING

- Open a window or turn on a ventilation fan or hood before self-cleaning.
- If the oven is heavily soiled with oil, self-clean the oven before using the oven again. The oil could cause a fire.
- Wipe up heavy soil on the bottom of the oven before using the Self Clean function.
- **Do not use oven cleaners.** Commercial oven cleaner or oven liner protective coating of any kind should not be used in or around any part of the oven.
- Never keep pet birds in the kitchen. The health of birds is extremely sensitive to the fumes released during an oven self-clean cycle. Fumes may be harmful or fatal to birds. Move birds to a well-ventilated room.
- Clean in the self-clean cycle only parts listed in this manual. Before self-cleaning the oven, remove the broiler pan, all oven racks, the meat probe and any utensils or food from the oven.
- Important Instruction. The oven displays a failure error code and sounds three long beeps if it malfunctions during the self-cleaning process. Switch off the electrical power to the main fuse or breaker and have the oven serviced by a qualified technician.
- It is normal for the cooktop of the range to become hot during a self-clean cycle. Do not touch the cooktop during a self-clean cycle.
- Never pour cold water over a hot oven for cleaning. Doing so may cause the oven to malfunction.
- Make sure oven lights are cool before cleaning.
- **Do not clean door gasket.** The door gasket is essential for a good seal. Care should be taken not to rub, damage, or move the gasket.
- If there is a fire in the oven during self-clean, turn the oven off and wait for the fire to go out. Do not force the door open. Introduction of fresh air at self-clean temperatures may lead to a burst of flame from the oven. Failure to follow this instruction may result in severe burns.
- For your safety, do not use high-pressure water cleaners or steam jet cleaners to clean the product.

COOK MEAT AND POULTRY THOROUGHLY

- To protect against food-borne illnesses, cook meat and poultry thoroughly. The USDA has indicated the following as safe minimum internal temperatures for consumption:
 - Ground meats: 160 °F
 - All poultry: 165 °F
 - Beef, veal, pork, or lamb: 145 °F
 - Fish/seafood: 145 °F

BUTTON CELL OR COIN BATTERIES WARNING SYMBOL



INGESTION HAZARD: This product contains a button cell or coin battery.

SAFETY STANDARD FOR BUTTON CELL OR COIN BATTERIES

WARNING

- **INGESTION HAZARD:** This product contains a button cell or coin battery.
- **DEATH** or serious injury can occur if ingested.
- A swallowed button cell or coin battery can cause **Internal Chemical Burns** in as little as **2 hours**.
- **KEEP** new and used batteries **OUT OF REACH** of **CHILDREN**.
- **Seek immediate medical attention** if a battery is suspected to be swallowed or inserted inside any part of the body.



- Remove and immediately recycle or dispose of used batteries according to local regulations and keep away from children.
 - Do NOT dispose of batteries in household trash or incinerate.
- Even used batteries may cause severe injury or death.
- Call a local poison control center for treatment information.
- Non-rechargeable batteries are not to be recharged.
- Do not force discharge, recharge, disassemble, heat above 140 °F or incinerate.
 - Doing so may result in injury due to venting, leakage or explosion resulting in chemical burns.
- Product contains non-replaceable batteries.
- Battery Type : ML621-TZ1
- Nominal Voltage : 3.0 V

PRODUCT OVERVIEW

Parts

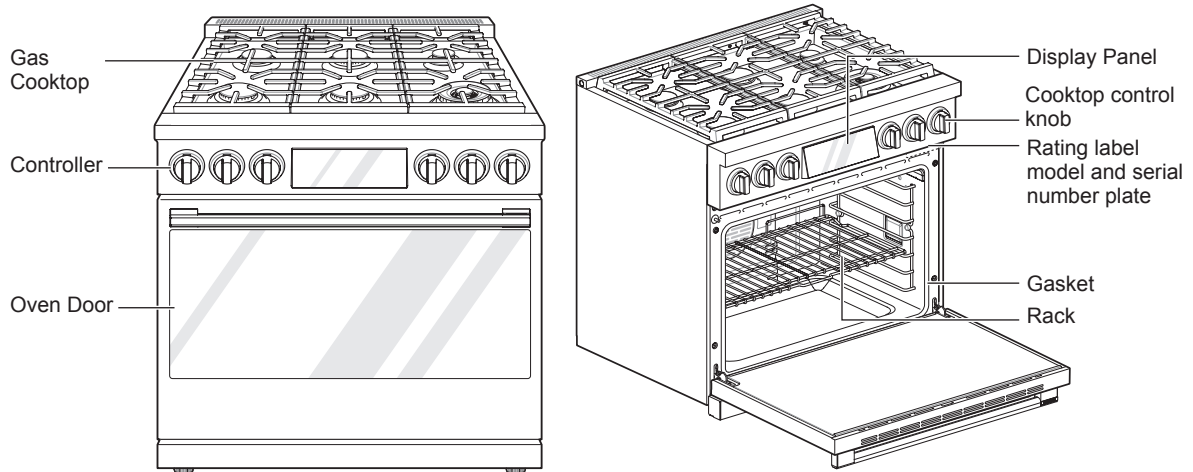

Accessories

Included Accessories

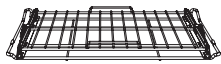

Gliding rack (1ea)

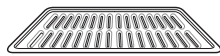

Grid (1ea)

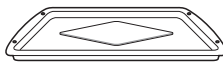

Broiler pan (1ea)

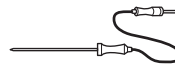

Meat probe (1ea)



Owner's manual (1ea)



Rack (2ea)

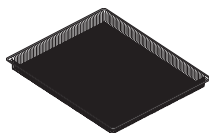

Air fry tray (1ea)

NOTE

- If accessories are missing, call 1-800-984-6306 or visit our website at: www.LGSIGNATURE.com
- For your safety and for extended product life, only use authorized components.
- The manufacturer is not responsible for product malfunction or accidents caused by the use of separately purchased, unauthorized components or parts.
- The images in this guide may be different from the actual components and accessories, which are subject to change by the manufacturer without prior notice for product improvement purposes.

INSTALLATION

Installation Overview

Please read the following installation instructions first after purchasing this product or transporting it to another location.

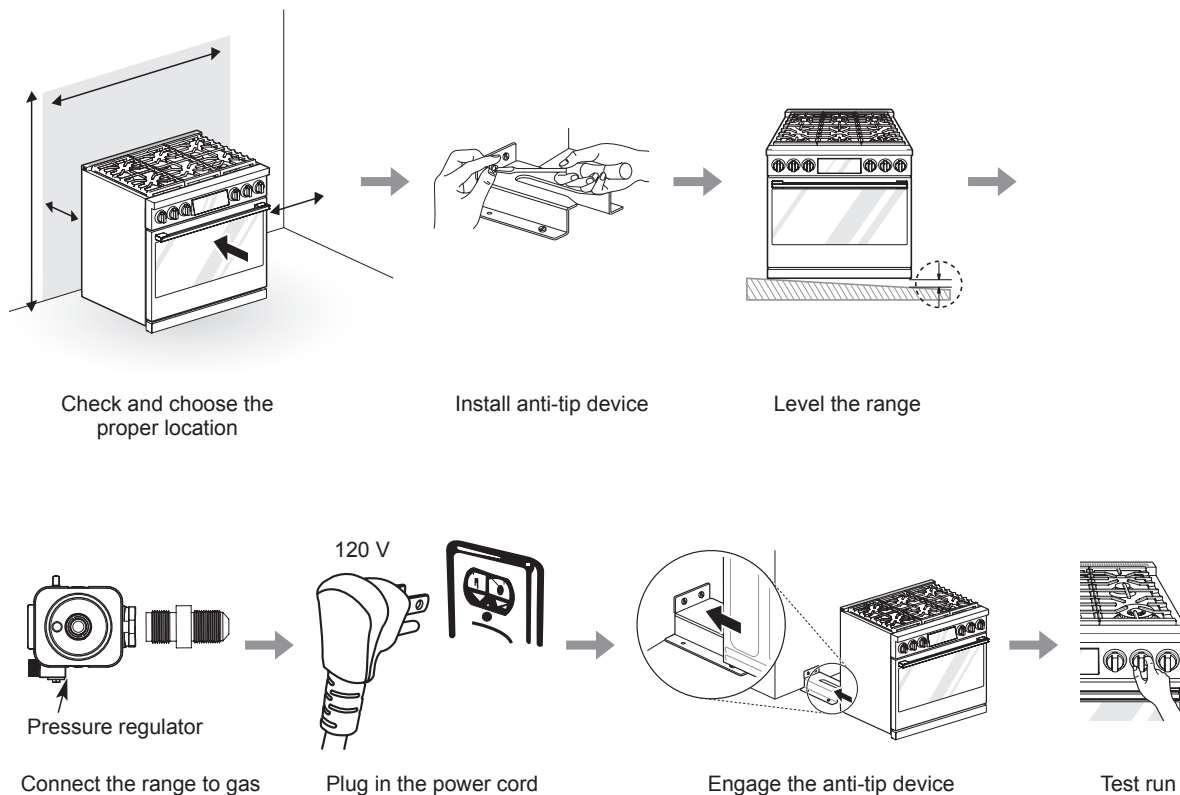

Product Specifications

The appearance and specifications listed in this manual may vary due to constant product improvements.

Oven Range Models	LPGU6319Y
Description	36" Gas Pro Range
Electrical requirements	4.8 A 120 VAC
Exterior dimensions	35 ⁷ / ₈ " (W) x 35 ¹ / ₄ " (H) x 26 ³ / ₄ " (D) (D with door closed) 91.1 cm (W) x 89.6 cm (H) x 67.9 cm (D) (D with door closed)
Height to cooking surface	36" (91.4 cm)
Total capacity	6.3 cu.ft.

Before Installing the Range

WARNING

Tip - Over Hazard

A child or adult can tip the range and be killed. Verify the anti-tip bracket has been installed. Ensure the anti-tip bracket is engaged when the range is moved.



Do not operate the range without the anti-tip bracket in place. Failure to follow these instructions can result in death or serious burns to children and adults.

To check that leveling leg is inserted into anti-tip bracket, grasp the top rear edge of the range and carefully attempt to tilt it forward.

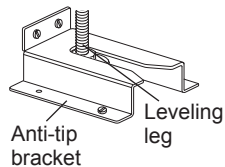

NOTE

- Important – Save for the local electrical inspector's use.

WARNING

- **Leveling legs must be extended lower than wheels to prevent range from moving.** This range is designed with wheels to make installation easier. During installation, make sure to extend the leveling legs until the wheels are lifted off the ground. Failure to do so can result in death or serious injury to children and adults.
- **To avoid damaging the leveling legs, retract them before moving the range for service or cleaning.**

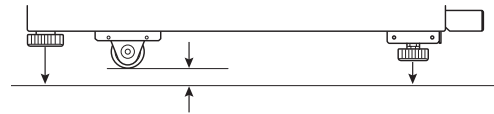

If you did not receive an anti-tip bracket with your purchase, call 1-800-984-6306 (LG SIGNATURE) to receive one at no charge.

WARNING

- **The information in this manual should be followed exactly.** Failure to do so may result in fire, electrical shock, property damage, personal injury, or death.
- **Wear gloves during the installation procedure.** Failure to do so can result in bodily injury.
- Make sure no parts came loose during shipping.

In the Commonwealth of Massachusetts

- This product must be installed by a licensed plumber or gas fitter.
- When using ball type gas shut-off valves, they must be the T-handle type.
- When using a flexible gas connector, it must not exceed 3 feet in length.

NOTE

- Observe all governing codes and ordinances.
- Have the installer show you the location of the circuit breaker or fuse. Mark it for easy reference.
- As when using any appliance generating heat, follow basic safety precautions.
- Be sure your range is installed and grounded properly by a qualified installer or service technician according to the installation instructions.
- Any adjustment and service should be performed only by qualified gas range installers or service technicians.

Preparing for Installation

Tools Needed



Phillips screwdriver



Flat-blade screwdriver

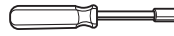

1/4" Nut driver

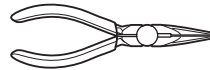

Pliers



Level



Open-end or adjustable wrench

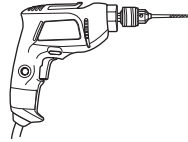

Drill



Safety glasses

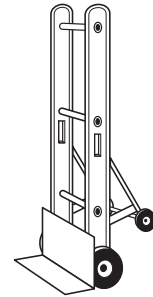

Dolly

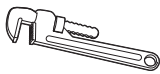

Pipe wrench (2ea)
(one for support)

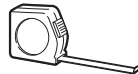

Tape measure



Gloves

Parts Provided

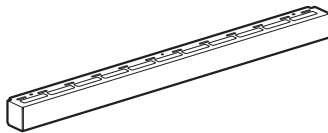

Front rail (1ea)

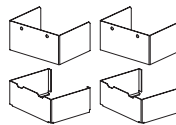

Leg cover (2 sets)



Screws (10ea)
(Leg cover, Front rail, 3 extras)

Anti-tip kit

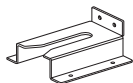

Anti-tip bracket (1ea)



Lag bolts (4ea)



Anchor sleeves (4ea)

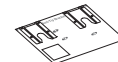

Template (1ea)

LP nozzle conversion kit

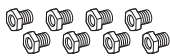

Cooktop nozzles (8ea)



Oven nozzles (2ea)



LPG Chokes (2ea)

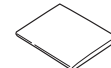

Installation guide (1ea)

Materials You May Need

- Gas line shut-off valve
- Pipe joint sealant that resists action of natural and LP gases
- Flexible metal appliance connector ($3/4$ " or $1/2$ " NPT x $1/2$ " I.D.)
Never use an old connector when installing a new range.
- Flare union adapter for connection to gas supply line ($3/4$ " or $1/2$ " NPT x $1/2$ " I.D.)
- Flare union adapter for connection to pressure regulator on range ($1/2$ " NPT x $1/2$ " I.D.)
- Liquid leak detector or soapy water
- Lag bolt or $1/2$ " O.D. sleeve anchor (for concrete floors only)

Ventilation Requirement

It is recommended that these ranges be installed in conjunction with a suitable overhead vent hood.

- Install a hood with at least 600 CFM above a 30" or 36" range.

Due to the high heat capacity of this unit, particular attention should be paid to the hood and ductwork installation to assure it meets local building codes.

WARNING

Do not install this product with an air curtain hood or other range hood that operates by blowing air down on the cooktop. This airflow may interfere with operation of the gas burners resulting in fire or explosion hazard.

See below for the minimum clearance from the cooking surface to any horizontal surface above the range. Failure to observe this clearance may result in a fire hazard.

- Installations without a hood require a 36" minimum distance to any overhead combustible surface.
- Installations with custom hoods containing exposed horizontal combustible surfaces require a hood with at least 600 CFM at least 36" above the cooking surface.
- For other hood installations, refer to the installation instructions included with the hood for specific clearances.

Proper Location

- The range is a free standing unit. If the unit is to be placed adjacent to cabinets, the clearances shown in "Install Clearance" are required. The same clearances apply to island installations, except for overhead cabinets, which must have a space wide enough to accept the flared island hood.
- The range should not be recessed into the cabinets beyond the edge of the front face of the oven. (see "Product Dimensions and Clearances")
- The maximum depth of overhead cabinets installed on either side of the hood is 13" (330 mm). Wall cabinets must be 18" (457 mm) above the countertop.
- There is a 36" (914 mm) minimum clearance required between the top of the cooking surface and the bottom of an unprotected cabinet. A 30" (762 mm) clearance can be used when the bottom of the wood or metal cabinet is protected by not less than 1/4" (6 mm) of a flame retardant material covered with not less than No. 28 MSG sheet steel, 0.015" (0.38 mm) thick stainless steel, 0.024" (0.61 mm) aluminum, or 0.02" (0.51 mm) thick copper.

- Non-combustible surfaces are as defined in 'National Fuel Gas Code'(ANSI Z223.1, Current Edition). Clearances from non-combustible materials are not part of the ANSI Z21.1 scope and are not certified by CSA. Clearances of less than 36 inches (914.4 mm) must be approved by the local codes and/or by the local authority having jurisdiction.

CAUTION

- **Avoid placing cabinets above the range.** To minimize the hazard caused by reaching over the open flames of operating burners, install a ventilation hood over the range that projects forward at least five inches beyond the front of the cabinets.
- **Do not locate your range where it may be subject to strong drafts.** Any openings in the floor or wall behind the range should be sealed. Make sure the openings around the base of the range that supply fresh air for combustion and ventilation are not blocked by carpeting or woodwork.
- **This range is for indoor, household use only.**
- **If the range is located near a window, do not hang long curtains or paper blinds on that window.**
- **Make sure wall covering, countertop and cabinets around the range can withstand the heat (up to 194 °F) generated by the range.** Discoloration, delamination or melting may occur. This range has been designed to comply with the maximum allowable wood cabinet temperature of 194 °F.
- **Before installing the range in an area covered with linoleum or other synthetic floor covering, make sure the floor covering can withstand temperatures of at least 160 °F.**
- **Use an insulated pad or 1/4 in. (6.4 mm) plywood under the range if installing the range over carpeting.**

When the floor covering ends at the front of the range, the area that the range will be installed on should be built up with plywood to the same level or higher than the floor covering. This will allow the range to be moved for cleaning and servicing, as well as provide proper air flow to the range.

18 INSTALLATION

Install Clearance

The location of gas burners and cooktop modules vary depending on the range model.

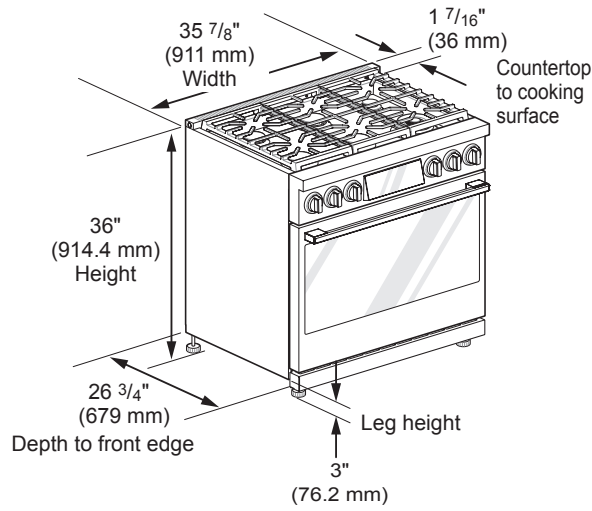

Universal Utility Locations

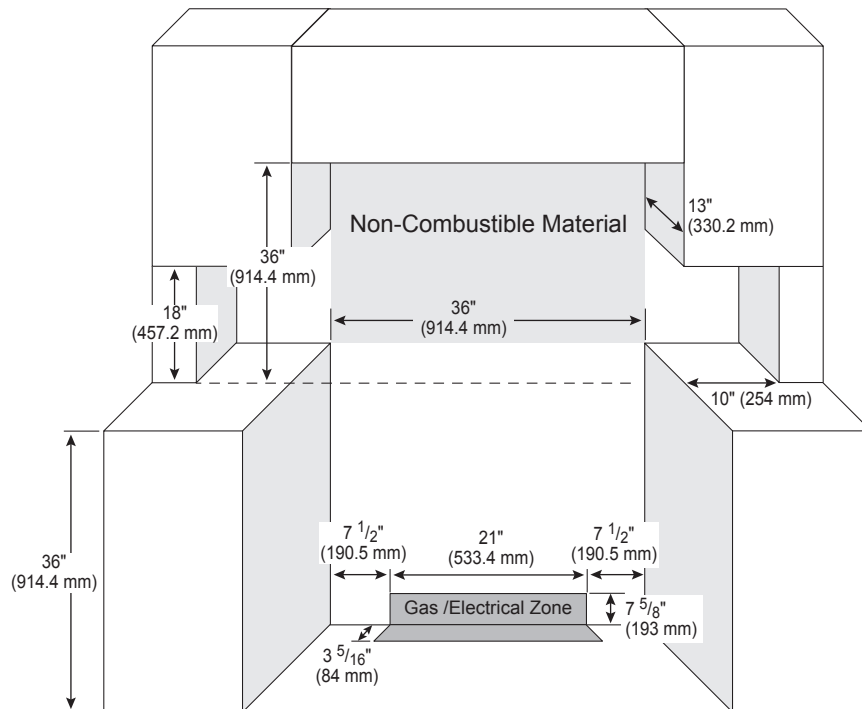

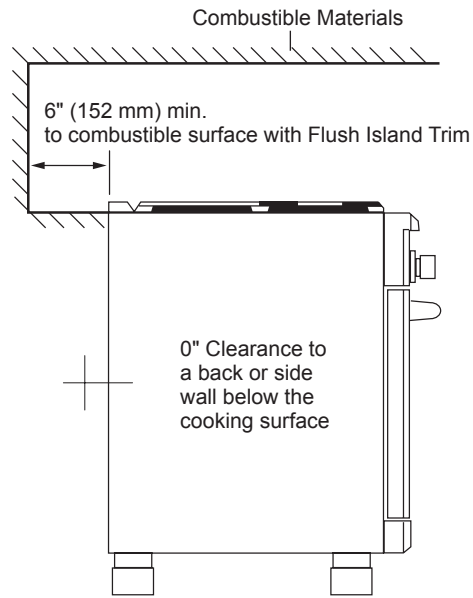

Product Dimensions and Clearances

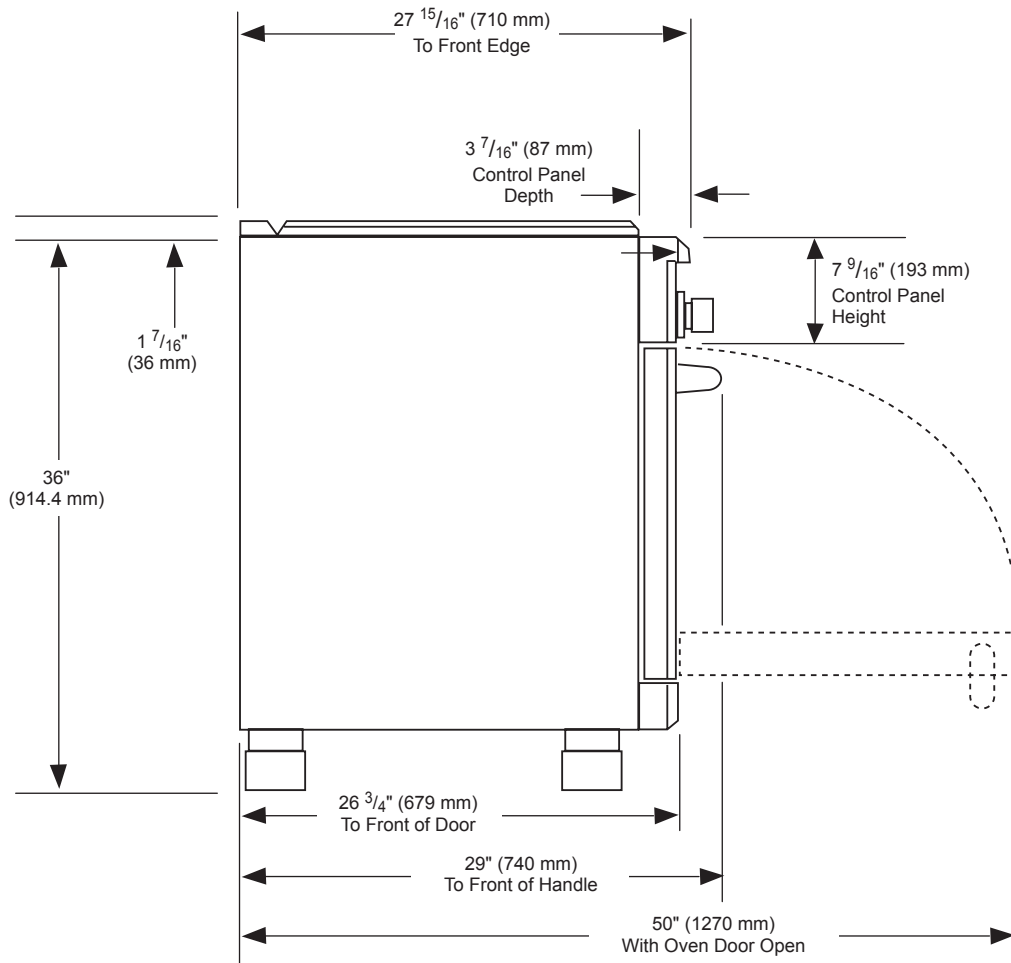

Gas Supply

The range is designed to operate at a pressure of 5" of water column on natural gas or 10" of water column on LP.

Make sure you are supplying the range with the type of gas for which it is configured.

This range is convertible for use with natural or LP gas. When using this range with LP gas, conversion must be made by a qualified LP installer before attempting to operate the range.

For proper operation, the pressure of natural gas supplied to the regulator must be between 6" and 10.5" of water column.

For LP gas, the pressure supplied to the regulator must be between 11" and 13" of water column. When checking for correct operation of the regulator, the inlet pressure must be at least 1" more than the operating (manifold) pressure as given above.

The pressure regulator located at the inlet of the range must remain in the supply line regardless of which type of gas is being used.

A flexible metal appliance connector used to connect the range to the gas supply line should have an I.D. of $\frac{5}{8}$ " and a maximum length of 5 feet. In Canada, flexible connectors must be single wall metal connectors less than 6 feet in length.

Installing the Range

Unpacking the Range

CAUTION

- **You should use 2 or more people to move and install the range. (Excessive Weight Hazard)** Failure to do so can result in back or other injury.
- **Do not use the door handles to push or pull the range during installation or when moving the range out for cleaning or service.** Doing so can result in serious damage to the door of the range.

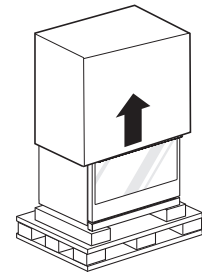
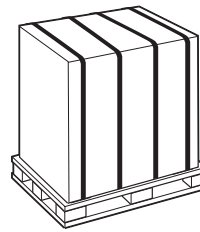

- 1** Cut the packing straps. Lift the carton straight up. Remove packing material, tape and any temporary labels from your range before using but leave the adhesive-backed foam layer over the brushed-metal surface, to protect the finish from scratches. Do not remove any warning-type labels, the model and serial number label, or the Tech Sheet that is located on the back of the range.
- 2** Remove the door(s). This will reduce the weight of the range during installation.
- 3** The grates, burner heads, burner caps, trays and oven racks must be removed to facilitate handling.

NOTE

Doors and passageways leading to the installation location require at least a 32" (813 mm) opening. If the opening is less than 32" (813 mm), the oven door(s) and control knobs must be removed.

Moving the Range

CAUTION

- Do not lift the range by the oven door's handle, as this may damage the door hinges and cause the door to fit incorrectly.
- Do not lift the appliance by the range's control panel.
- Rings, watches, and any other loose items that may damage the unit or otherwise might become entangled with the unit should be removed.
- Hidden surfaces may have sharp edges. Use caution when reaching behind or under the appliance.
- Do not use a hand truck or appliance dolly on the back or front of the unit. Handle from the side only.
- Due to the weight, it is strongly recommended that a furniture dolly with soft wheels or an air lift be used to move this unit. The weight must be supported uniformly across the bottom.
- All ranges are held to the pallet by (4) brackets through a wood block
- To avoid damaging the leveling legs, retract them before moving the range for service or cleaning.

- 1 Remove the two screws on each bracket that secure the product to the pallet.

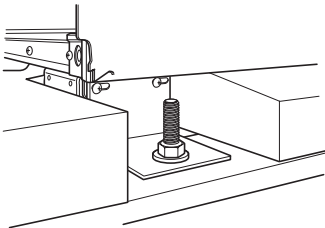

- 2 Remove the oven door and racks.

NOTE

- Instructions for removing the oven doors can be found in the **MAINTENANCE** section.

- 3 Carefully tilt the range from the side and insert a dolly under the range to remove the range from the pallet. Use additional help as required to remove the product from the pallet. To prevent damage to the sides of the range, it will be necessary to pad the corners beneath the straps on the dolly.

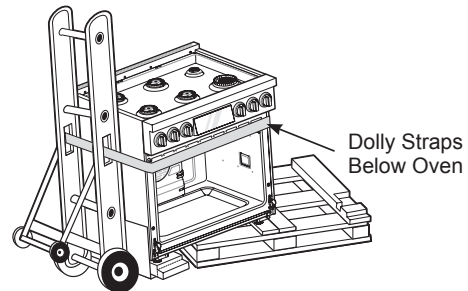
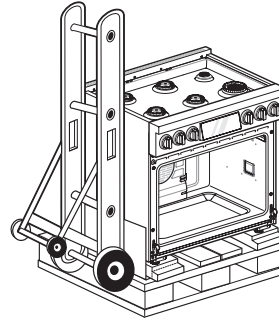

- 4 Transport the range on the furniture dolly close to its final location, tip the range back to level, and carefully remove the dolly.

Your range is heavy and can be installed on soft floor coverings such as cushioned vinyl or carpeting. Use care when moving the range on this type of flooring. Use a belt when moving the range to prevent damaging the floor. Or slide the range onto cardboard or plywood to avoid damaging the floor covering.

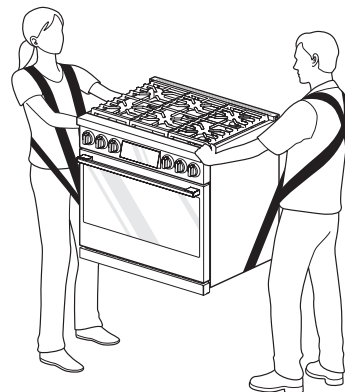

CAUTION

- You should use two or more people to move and install the range. (**Excessive Weight Hazard**) Failure to do so can result in back or other injury.

Installing the Anti-tip Device

WARNING

Tip - Over Hazard

A child or adult can tip the range and be killed. Verify the anti-tip bracket has been installed. Ensure the anti-tip bracket is engaged when the range is moved. Do not operate the range without the anti-tip bracket in place. Failure to follow these instructions can result in death or serious burns to children and adults.



To check that leveling leg is inserted into anti-tip bracket, grasp the top rear edge of the range and carefully attempt to tilt it forward.

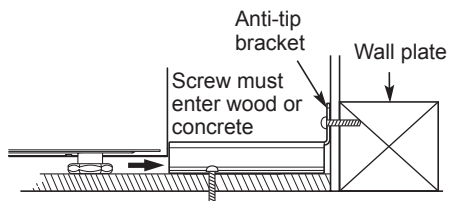
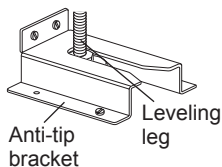

Locate the anti-tip bracket using the template.

An anti-tip bracket is packaged with the template. The instructions include necessary information to complete the installation. Read and follow the range installation instruction sheet (template).

WARNING

- A child or adult can tip the range and be killed.
- Install the anti-tip device to the structure and/or the range. Verify the anti-tip device has been properly installed and engaged by following the instructions on this template.
- Engage the range to the anti-tip device following the instructions on this template. Ensure the anti-tip device is reengaged when the range is moved by following the instructions on this template.
- Re-engage the anti-tip device if the range is moved. Do not operate the range without the anti-tip device in place and engaged.
- See installation instructions for details.
- Failure to do so can result in death or serious burns to children or adults.

Leveling the Range

Front Legs

Level the range by adjusting the leveling legs with a wrench. Extending the legs slightly may also make it easier to insert the rear leg into the anti-tip bracket.

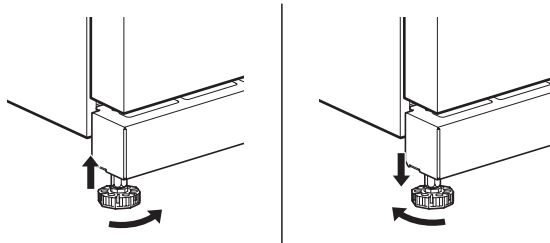

Rear Legs

To adjust the rear leveling legs, remove the 4 screws at the front of the vent trim and remove the trim.

Use an adjustable 6 mm box wrench to turn the rear leg extension rods at each corner.

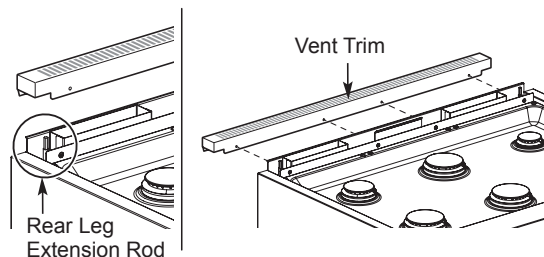

Use a level to check your adjustments. Place the level diagonally on the oven rack, and check each direction for level.

First check direction ①.

Then check direction ②. If the level doesn't show level on the rack, adjust the leveling legs with a wrench.

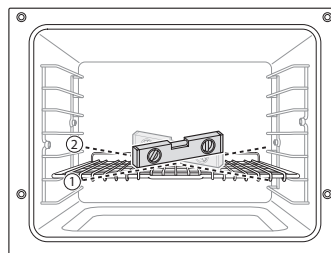

Installing the Leg Cover

- 1 Remove the plastic covers from the stainless steel leg covers.
- 2 Slide each small leg cover inside a larger leg cover. Cutouts should face up and both covers should be open at the back.

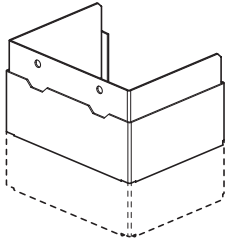

- 3 Use the assembled covers to conceal the front leveling legs.
- 4 Place the outer covers on the floor and slide the inner covers up until the holes at the top front snap over the dimples on the flanges on the bottom of the range.

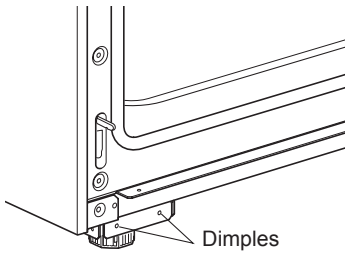

- 5 Insert the provided screws through the holes in the leg cover assemblies to secure them in place.

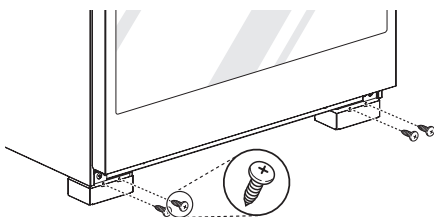

Installing Front Rail

- 1 Remove the plastic film from the stainless steel front rail.
- 2 Insert the front rail onto the flange below the oven door, aligning the holes in the top of the rail with the holes in the flange.

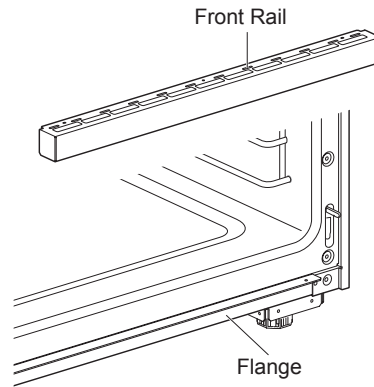

- 3 Use the 3 screws provided to secure the front rail to the flange.

Connecting the Range to Gas

This appliance must be installed in accordance with local codes or, in the absence of local codes, with the National Fuel Gas Code, ANSI Z223.1/NFPA 54 or, in Canada, the Natural Gas and Propane Installation Code, CSA B149.1.

Shut off the range gas supply valve before removing the old range and leave it off until the new hook-up has been completed.

Because hard piping restricts movement of the range, a CSA International-certified flexible metal appliance connector should be used unless local codes require a hard-piped connection.

A manual valve must be installed in an accessible location in the gas piping external to the appliance for the purpose of turning on or shutting off gas to the appliance.

Never reuse an old connector when installing a new range.

To protect against gas leaks, use a qualified pipe joint sealant on all external threads.

- 1 An inlet pipe is set on the left rear of this appliance. Hook up a gas hose that has $\frac{1}{2}$ " NPT internal thread to the inlet pipe using a wrench.
- 2 Apply sealing compound or Teflon tape at the connection.
- 3 When all connections have been made, be sure all range controls are in the **Off** position and turn on the main gas supply valve. Gas leaks may occur in your system and create a hazard. Gas leaks may not be detected by smell alone.

Check all gas connection joints and fittings for leaks with a non-corrosive leak detection fluid, then wipe off.

Gas suppliers recommend you purchase and install a UL/CSA approved gas detector. Install and use in accordance with the installation instructions.

WARNING

- Do not use a flame to check for gas leaks.
- The appliance and its individual shut-off valve must be disconnected from the gas supply piping system during any pressure testing of that system at test pressures in excess of $\frac{1}{2}$ psi (3.5 kPa).
- The appliance must be isolated from the gas supply piping system by closing its individual manual shut-off valve during any pressure testing of the gas supply piping system at test pressures equal to or less than $\frac{1}{2}$ psi (3.5 kPa).

Flexible Connector Hookup

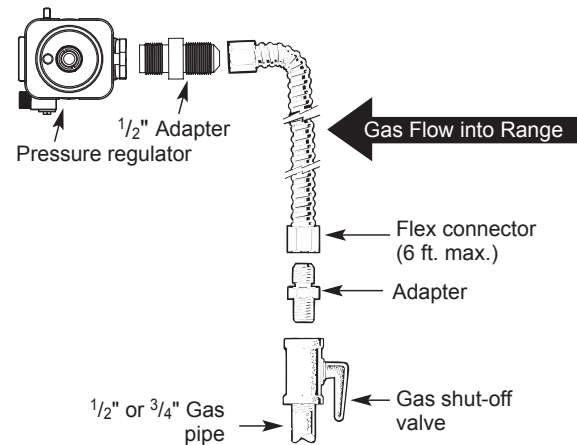

Installer: Inform the consumer of the location of the gas shutoff valve.

Pressure Regulator Position

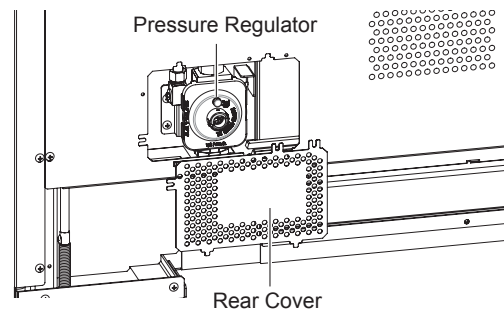

NOTE

Use a coin to unscrew the circular cap on the pressure regulator.

Electrical Connections

Electrical Requirements

Connect to a 120 Volt, 60 Hz, properly grounded dedicated circuit protected by a 15 or 20 Amp circuit breaker, or slow blow fuse.

If an external electrical source is utilized, the appliance, when installed, must be electrically grounded in accordance with local codes or, in the absence of local codes, with the National Electrical Code, ANSI/NFPA 70 or the Canadian Electric Code, CSA C22.1-02.

Grounding

IMPORTANT: FOR PERSONAL SAFETY, THIS APPLIANCE MUST BE PROPERLY GROUNDED.

The power cord of this appliance is equipped with a 3-prong (grounding) plug which mates with a standard 3-prong grounding wall receptacle to minimize the possibility of electric shock hazard from this appliance.

The customer should have the wall receptacle and circuit checked by a qualified electrician to make sure the receptacle is properly grounded.

Where a standard two-prong wall receptacle is encountered, it is the personal responsibility and obligation of the customer to have it replaced with a properly grounded three-prong wall receptacle.

DO NOT, UNDER ANY CIRCUMSTANCES, CUT OR REMOVE THE THIRD (GROUND) PRONG FROM THE POWER CORD.

Do not use an adapter plug. Disconnecting the power cord places undue strain on the adapter and leads to eventual failure of the adapter ground terminal.

Installation must conform with local codes or, in the absence of local codes, with the National Fuel Gas Code, ANSI Z223.1/NFPA 54 or, in Canada, the Natural Gas and Propane Installation Code, CSA B149.1.

The installation of appliances designed for mobile home installation must conform with the Manufactured Home Construction and Safety Standard, Title 24 CFR, Part 3280 (formerly the Federal Standard for Mobile Home Construction and Safety, Title 24, HUD, Part 280) or, when such standard is not applicable, the Standard for Manufactured Home Installations, latest edition (Manufactured Home Sites, Communities and Set-Ups), ANSI A225.1, latest edition, or with local codes. In Canada, mobile home installation must be in accordance with the current CAN/CSA Z240/MH Mobile Home Installation Code.

Sealing the Openings

Seal any openings in the wall and floor after electrical and gas supply connections are completed.

Required Method



CAUTION

Have the circuit checked by a qualified electrician to make sure the receptacle is properly grounded.

Engaging the Anti-tip Device

- Move the range close enough to the opening to plug into the receptacle.
- Slide the range into position ensuring that the back leg slides under the anti-tip bracket. The range should sit flush against the back wall when properly installed.
- Carefully attempt to tip the range forward to ensure that the anti-tip bracket is engaged properly. If properly installed, the anti-tip bracket will prevent the range from being tipped. If the range can be tipped, reinstall the range until the anti-tip bracket is properly installed and the range will not tip forward.
- Turn on electrical power. Check the range for proper operation.

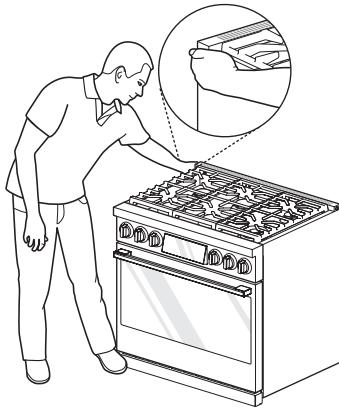

Checking Ignition of the Surface Burners

Electric Ignition

Select a surface burner knob and simultaneously push in and turn to the **Lite** position. You will hear a clicking sound indicating proper operation of the spark module.

Once the air has been purged from the supply lines the burner should ignite within 4 seconds. After the burner ignites, rotate the knob out of the **Lite** position. Try each burner in succession until all burners have been checked.

Quality of Flames

The combustion quality of the burner flames needs to be confirmed visually.



A Yellow flames - Call for service.



B Yellow tips on outer cones - This is normal for LP gas.



C Soft blue flames - This is normal for natural gas.

NOTE

- With LP gas, some yellow tipping on outer cones is normal.

Test Run

Check if the range is properly installed and run a test cycle.

- 1 Remove all packing materials from inside the oven. Press **Power** button located next to the display and set initial settings such as language and time. (Refer to "Getting Started" in the Operation section.)
- 2 Check the operation of the oven. Select Bake in the cooking mode screen then Start.
- 3 The oven should finish preheating in 15 minutes.
- 4 After making sure the oven operates properly, turn the temperature in the oven to 550 °F (288 °C) and leave the oven on for at least an hour. This helps remove any residual oil which might cause smoke or odor when first using the oven.

NOTE

Smoke may come out of the range when it is first used.

Adjusting the Surface Burner to the Low Flame (Simmer) Setting

- 1 Light all surface burners.
- 2 Turn the knob on the burner being adjusted to **Lo**.
- 3 Remove the knob and knob ring.
- 4 Insert a small, flat-blade screwdriver with a minimum length of 3" (76.2 mm) and a diameter of 3/32" (2.4 mm) into the opening marked below.

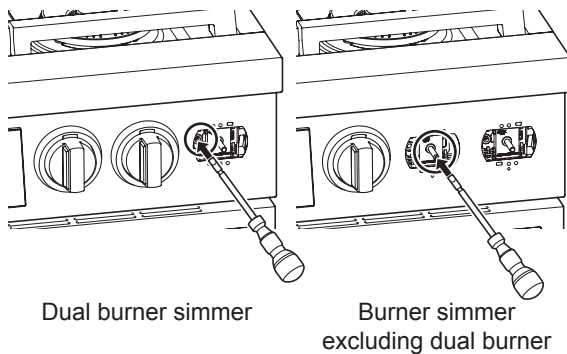

- 5 Turn the screw to adjust.
 - Hold the valve shaft with one hand while turning the screw to adjust with the other.
- 6 Replace the knob.
- 7 Test the flame stability.
 - Test 1: Turn the knob from **Hi** to **Lo** quickly. If the flame goes out, increase the flame size and test again.
 - Test 2: With the burner on a **Lo** setting, open and close the oven door quickly. If the flame is extinguished by the air currents created by the door movement, increase the flame height and test again.
- 8 Repeat steps 1~7 for each surface burner.

NOTE

- The product is shipped with the low flame (Simmer) setting at the lower limit. It cannot be set any lower.

OPERATION

Control Panel Overview

The position of the control knobs and buttons varies by model.

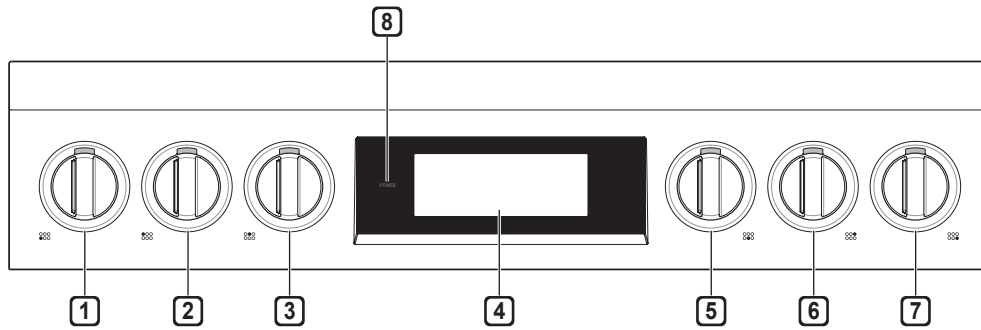

1 Left Front Burner Control

2 Left Rear Burner Control

3 Center Rear Burner Control

4 LCD Touchscreen for Oven

5 Center Front Burner Control

6 Right Rear Burner Control

7 Right Front Burner Control









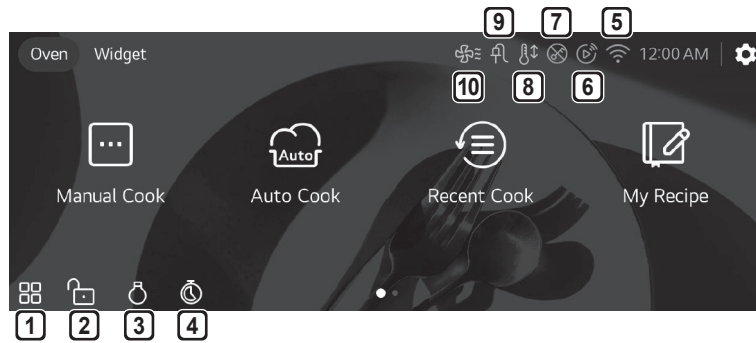

8 LCD Display On/Off

NOTE

Touch the LCD display to activate the screen when it's idle.

Display Icons



- | | |
|--|---|
| <p>1  All Modes Icon
Touch to browse all modes.</p> <p>2  Control Lock Icon
Touch to turn Control Lock on/off</p> <p>3  Oven light Icon
Touch to turn light on/off</p> <p>4  Timer Icon
Touch to set a timer</p> <p>5  Wi-Fi Icon</p> <ul style="list-style-type: none"> • Appears when range is connected to Wi-Fi • Appears when range is disconnected from Wi-Fi or is not connected to LG ThinQ app. | <p>6  Remote Start Icon
Appears when Remote Start is active</p> <p>7  Door Lock Icon
Appears when Door is locked.</p> <p>8  Auto Conversion Icon
Appears when Convection Auto Conversion is turned on</p> <p>9  Probe Icon
Appears when probe is connected</p> <p>10  Oven Cooling Icon
Appears during or after oven operation to indicate cooling fan is running in oven</p> |
|--|---|

Getting Started

After turning on the range for the first time, adjust the settings to suit your preferences.

- 1 If needed, touch POWER to wake up the display.



- 2 Select the desired language and touch **Next**.

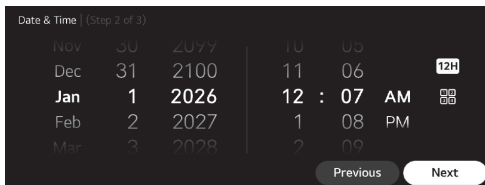

- 3 Scroll the fields up or down to set the correct date on the left.
- 4 Set the correct time of day and choose between a 12-hour or 24-hour time format by touching the 12H icon . You can also touch the number pad icon and enter the desired numbers, then touch **Next**.
- 5 Read through the application guide in the display and touch **Done**.
- 6 The main screen appears in the display.

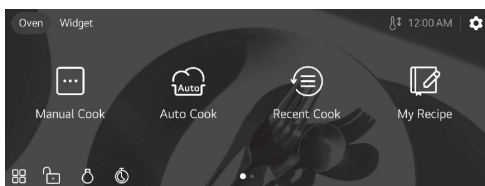

Changing Oven Settings

Settings

To adjust settings after the initial setup, touch the display to open the Main screen. Touch the settings icon at the top right of the Main screen.

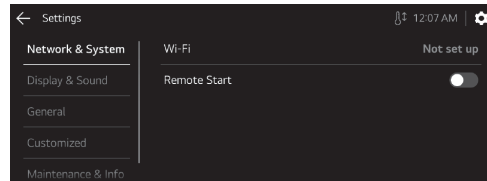

Location of Settings

- Network & System: Wi-Fi, Remote Start
- Display & Sound: Control Lock, Display, Brightness, Clock Theme, Volume
- General: Language, Date & Time, Temperature Unit, Sabbath
- Customized : Start Screen, Temperature Adjustment, Convection Auto Conversion, Preheat End Light
- Maintenance & Info : Smart Diagnosis, Factory Reset, Open Source License

Wi-Fi

Connect the appliance to a home Wi-Fi network to use Remote Start and other smart functions. See the Smart Functions section for more details.



Setting Up Wi-Fi

- 1 Touch the settings icon at the top right of the Main screen.
- 2 Touch **Wi-Fi** on the right menu.
- 3 Touch **Set Up Wi-Fi**, and follow the instructions in the Wi-Fi Guide on your smartphone.
- 4 If connected, the Wi-Fi icon appears at the top of the display.

Remote Start

Remotely starts or stops the preheating function of the appliance. The appliance must be registered on a home Wi-Fi network to use Remote Start.



Setting Remote Start

- 1 Touch the settings icon  at the top right of the Main screen.
- 2 Touch the toggle switch next to **Remote Start** on the right menu.
- 3 If ON is selected, the Remote Start icon  appears at the top of the display.



Control Lock

The Control Lock feature automatically locks the oven door and prevents most oven controls from being turned on.

Lock

- 1 Touch the settings icon  at the top right of the Main screen. Then touch **Display & Sound** on the second row of the left menu.
- 2 Touch the toggle switch next to **Control Lock** on the right menu.
- 3 When Control Lock is turned on, the lock icon  appears at the bottom left of the display.

Unlock

- 1 Touch any part of screen while Control Lock is on.
- 2 A popup screen appears. Touch the lock icon  for 3 seconds.
- 3 When Control Lock is turned off, the lock icon changes to an unlocked icon .

NOTE

- You can quickly turn on **Control Lock** by touching the lock icon  at the bottom left of the Main screen.

Display

Set the length of time before the display sleeps.

There are three options you can select.

- **On** : Always on
- **Night mode** : Turns display off from 10:00 PM to 5:00 AM.
- **Off** : Automatically turns off if idle for 5 minutes.

Setting Display Option

- 1 Touch the settings icon  at the top right of the Main screen. Then touch **Display & Sound** on the second row of the left menu.
- 2 Touch **Display** on the right menu.
- 3 Select the desired option.

NOTE

If the display is set to **Off**, it will turn off after 5 minutes if idle. The display cannot be used in idle mode. Touch the LCD display to activate the screen.

Brightness

Adjust the brightness of the LCD display from 20% to 100% in increments of 20%.

Setting Display Brightness

- 1 Touch the settings icon  at the top right of the Main screen. Then touch **Display & Sound** on the second row of the left menu.
- 2 Touch **Brightness** on the right menu.
- 3 Adjust the display brightness by touching and dragging the dot across the bar, by tapping anywhere on the bar, or by touching **+** or **-**.

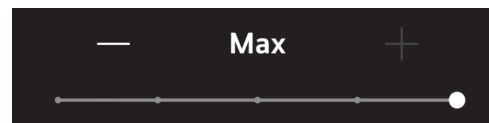

Clock Themes

There are four different clock themes available, including several analog and digital clocks.

Selecting a Clock Theme

- 1 Touch the settings icon  at the top right of the Main screen. Then touch **Display & Sound** on the second row of the left menu.
- 2 Touch **Clock Theme** on the right menu, and swipe to browse through the clock themes.
- 3 Select a clock theme and touch OK.

Volume

Adjust the volume of the cooktop and oven controls.

Setting the Volume

- 1 Touch the settings icon  at the top right of the Main screen. Then touch **Display & Sound** on the second row of the left menu.
- 2 Touch **Volume** on the right menu.
- 3 Adjust the volume by touching and dragging the dot across the bar, by tapping anywhere on the bar, or by touching **+** or **-**.

Language Selection

Set the display language to English, French or Spanish.



Selecting a Language

- 1 Touch the settings icon  at the top right of the Main screen. Then touch **General** on the third row of the left menu.
- 2 Touch **Language** on the right menu.
- 3 Select the desired language.

Date & Time

The date and time show in the LCD display when the ovens are not in use.

Setting Date & Time

- 1 Touch the settings icon  at the top right of the Main screen. Then touch **General** on the third row of the left menu.
- 2 Touch **Date & Time** on the right menu.
- 3 Touch **Date**, and set the correct date by scrolling, then touch OK.
- 4 Touch **Time**, and set the correct hour and minutes by scrolling. You can also touch the number pad icon  on the top right corner and enter the desired numbers. Then touch OK.
- 5 If desired, touch the toggle switch next to **24-Hour Time**.

NOTE

- Toggle On : 24-hour time format
- Toggle Off : 12-hour time format (AM/PM)

Temperature Unit

Set the oven temperature display to show either Fahrenheit or Celsius units.

The oven defaults to Fahrenheit unless changed by the user.

Setting Temperature Unit

- 1 Touch the settings icon  at the top right of the Main screen. Then touch **General** on the third row of the left menu.
- 2 Touch **Temperature Unit** on the right menu.
- 3 Select °F or °C.

Sabbath Mode

Sabbath mode is used on the Jewish Sabbath and Holidays.

While the oven is in Sabbath mode, the temperature cannot be changed and the timer, light, and alarm functions are disabled. Only the cooking mode and set temperature appear in the display.

To use only the gas cooktop on the Holidays without having the oven on, put the oven into Sabbath mode with the cook time set for 1 minute. The oven will turn off after 1 minute but the range will remain in Sabbath mode.

Setting Sabbath Mode

- 1 Disconnect the probe. The Probe function is not available in Sabbath mode.
- 2 Touch the settings icon  at the top right of the Main screen. Then touch **General** on the third row of the left menu.
- 3 Touch **Sabbath** on the right menu.
- 4 Set the oven temperature and cook time. Then touch **Start**.
- 5 To stop Sabbath mode, press POWER on the LCD display.

NOTE

- If a cook time is set, the oven turns off automatically at the end of the cook time, without chiming. The oven remains in Sabbath mode, but is turned off.
- If no cook time is set, the oven will not automatically turn off.
- After a power failure, the display will turn back on in Sabbath mode, but the oven will be off.

Start Screen

This feature allows you to change the first LCD screen displayed after touching the screen when it is idle.

Setting the Start Screen

- 1 Touch the settings icon  at the top right of the Main screen. Then touch **Customized** on the fourth row of the left menu.
- 2 Touch the **Start Screen** on the right menu.
- 3 Select the desired setting.

Temperature Adjustment

Your new oven may cook differently from the one it replaced. Use your new oven for a few weeks to become more familiar with it before adjusting the temperature. Start by raising or lowering the temperature 15 °F / 8 °C. Based on initial results, readjust the amount until satisfied. The temperature can be raised or lowered by 35 °F / 19 °C.

Adjusting the Temperature

- 1 Touch the settings icon  at the top right of the Main screen. Then touch **Customized** on the fourth row of the left menu.
- 2 Touch **Temperature Adjustment** on the right menu.
- 3 To make large adjustments, drag the central indicator toward the + or - ends of the scale or tap a location on the scale. To make small adjustments, tap + or - to raise or lower the temperature in 1-degree increments. Tap and hold + or - to scroll up or down the scale.

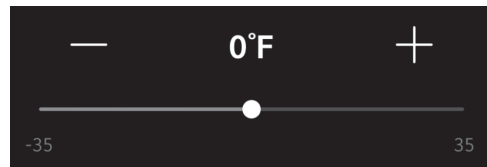



Convection Auto Conversion

There is no need to remember to convert standard recipe temperatures for convection cooking. Convection Auto Conversion automatically subtracts 25 °F / 14 °C from the set temperature when a convection cooking mode is selected. The converted temperature appears in the display once preheating is finished.

For example, select Convection Bake and enter 350 °F. The temperature will auto-convert to 325°F and display the converted temperature.

Convection Auto Conversion is turned ON by default.

Turning Convection Auto Conversion On/Off

- 1 Touch the settings icon  at the top right of the Main screen. Then touch **Customized** on the fourth row of the left menu.
- 2 Touch the toggle switch next to **Convection Auto Conversion** on the right menu.
- 3 When Convection Auto Conversion is ON, the icon  appears at the top of the display.

NOTE

If Convection Auto Conversion is ON, the icon  flashes in the display while cooking in a convection mode.

Preheat End Light

When the oven reaches its set-temperature, the preheating alarm light flashes 5 times or until the oven door is opened.

You can turn the preheat end light on or off.

Turning Preheat End Light On/Off

- 1 Touch the settings icon  at the top right of the Main screen. Then touch **Customized** on the fourth row of the left menu.
- 2 Touch the toggle switch next to **Preheat End Light** on the right menu.

Smart Diagnosis™

Smart Diagnosis™ can be run through a smartphone application or by calling for support. Place your smartphone's mouthpiece near the top left corner of the screen. See "Smart Diagnosis Function" in the Smart Functions section for detailed instructions.

- 1 Touch the settings icon  at the top right of the Main screen. Then touch **Maintenance & Info** on the last row of the left menu.
- 2 Touch **Smart Diagnosis** on the right menu.
- 3 Touch **Start** to start the diagnostic tone.

Factory Reset

This function returns all settings to the factory defaults.

- 1 Touch the settings icon  at the top right of the Main screen. Then touch **Maintenance & Info** on the last row of the left menu.
- 2 Touch **Factory Reset** on the right menu.
- 3 If you want to reset data to the factory defaults, touch **RESET**.

WARNING

- All stored data will be deleted.

Open Source License

This screen displays a list of the open source software contained in this product. Refer to the indicated licenses for the terms and conditions of their use.

- 1 Touch the settings icon  at the top right of the Main screen. Then touch **Maintenance & Info** on the last row of the left menu.
- 2 Touch **Open Source License** on the right menu.
- 3 Scan QR code or tap "View Contents" to read Open Source License contents.

Using the Cooktop

Gas Cooktop Module

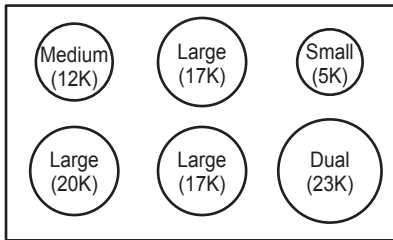

Medium and Large Burners

The medium and large burners are the primary burners for most cooking. These general purpose burners can be turned down from Hi to Lo to suit a wide range of cooking needs.

Small Burner

The smallest burner is used for delicate foods such as sauces or foods that require low heat for a long cooking time.

Dual Burner

The dual burner is the maximum output burner. Like the other burners, it can be turned down from Hi to Lo for a wide range of cooking applications. This burner is also designed to quickly bring large amounts of liquid to a boil. It can be used with cookware 10 inches or larger in diameter.

NOTE

- The central display does not control the cooktop modules.

The Gas Surface Burners

Before Use

Read all instructions before using.

Make sure that all burners are properly placed.

Burner locations differ depending on the range model. Burner locations can be found under "Using the Cooktop."

Make sure that all grates are properly placed before using the burners.

CAUTION

Do not operate the burners for an extended period without cookware on the grate.

The finish on the grate may chip without cookware to absorb the heat.

Make sure the burners and grates have cooled down before touching them, or placing a pot holder, cleaning cloth, or other materials on them.

Touching grates before they cool down may cause burns.

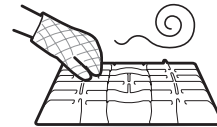

CAUTION

WHAT TO DO IF YOU SMELL GAS

- Open windows.
- Do not try to light any appliance.
- Do not touch any electrical switch.
- Do not use any phone in your building.
- Immediately call your gas supplier from a neighbor's phone. Follow the gas supplier's instructions.
- If you cannot reach your gas supplier, call the fire department.

NOTE

Electric spark igniters from the burners cause a clicking noise. If the flame goes out, the reignition system reignites the burners automatically.

Using the Gas Surface Burners

- 1 Be sure that all of the surface burners and grates are placed in the correct positions.
- 2 Place cookware on the grate.
- 3 Press in the side button on the knob.
- 4 Push the control knob in and turn to the **LITE** position to light the burner.

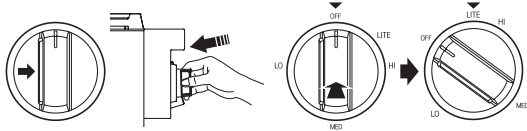

NOTE

- The electric spark ignition system makes a clicking noise.
- To use the cooktop knobs without pressing in the side button, use the knob lock function.

- 5 Turn the control knob to control the flame size.

CAUTION

Do not attempt to disassemble or clean around any burner while another burner is on. All the spark igniters on the cooktop will activate when igniting just one burner. An electric shock may result causing you to knock over hot cookware.

Using the Knob Lock

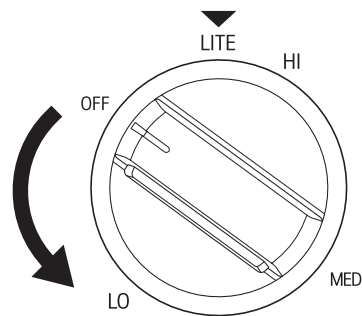

You can adjust the Knob Lock on each cooktop knob so you don't have to press the button in to use the knob. Remove and adjust one knob at a time.

- 1 Make sure the knob is in the **OFF** position and pull it straight off the stem.
- 2 On the back of the knob ring, rotate the black tab to the **2 Step** or **3 Step** position.
 - If you slide the tab to the **2 Step** **1** position, the knob can be used without pressing in the button.
 - If you slide the tab to the **3 Step** **2** position, you must press in the button to use the knob.

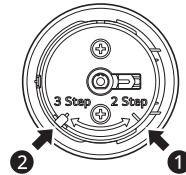

- 3 Once the Knob Lock is adjusted as desired, reinstall the knob. To reinstall, hold the knob with the **OFF** label at the top and slide the knob directly onto the stem.

NOTE

- The black tab must be aligned with the **2 Step** or **3 Step** mark to ensure proper operation of the knob and button.

Setting the Flame Size

Watch the flame, not the knob, as you reduce heat. Match the flame size on a gas burner to the cookware being used for fastest heating.

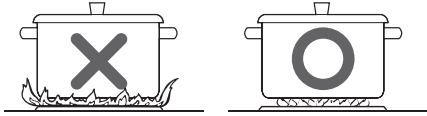

CAUTION

Never let the flames extend up the sides of the cookware.

NOTE

- The flames on the surface burners may burn yellow in the presence of high humidity, such as a rainy day or a nearby humidifier.
- After LP gas conversion, flames can be bigger than normal when you put a pot on the surface burner.
- When turning a surface burner quickly from high heat to simmer, make sure the flames stay lit. See **Checking Ignition of the Surface Burners** section to adjust the burner flames, if necessary.

In Case of Power Failure

If you experience a power outage, you can carefully light the gas surface burners on the range with a match. Gas burners in use when the power goes out will continue to operate normally.

- 1 Hold a lit match to the burner, then push in the control knob.
- 2 Turn the control knob to the **Lo** position.

CAUTION

Use extreme caution when lighting burners with a match. Doing so can cause burns and other damage.

Cookware for Gas Burners

Aluminum	Medium-weight cookware is recommended because it heats quickly and evenly. Most foods brown evenly in an aluminum skillet. Use saucepans with tight fitting lids when cooking with minimum amounts of water.
Cast-Iron	If heated slowly, most skillets will give satisfactory results.
Stainless Steel	This metal alone has poor heating properties and is usually combined with copper, aluminum or other metals for improved heat distribution. Combination metal skillets work satisfactorily if they are used with medium heat as the manufacturer recommends.
Enamelware	Under some conditions, the enamel of this cookware may melt. Follow cookware manufacturer's recommendations for cooking methods.
Glass	There are two types of glass cookware: those for oven use only and those for top-of-range cooking.
Heatproof Glass Ceramic	Can be used for either surface or oven cooking. It conducts heat very slowly and cools very slowly. Check cookware manufacturer's directions to be sure it can be used on gas ranges.

CAUTION

Do not use a wok. It may tip over and cause injury.

Using Stove-Top Grills

Do not place stove-top grills on the burner.



CAUTION

Do not use stove top grills on the surface burners. Using a stove top grill on the surface burner will cause incomplete combustion and can result in exposure to carbon monoxide levels above allowable current standards. This can be a health hazard.

Using the Oven

Before Using the Oven

NOTE

- Because the oven temperature cycles, an oven thermometer placed in the oven cavity may not show the same temperature that is set on the oven.
- It is normal for the convection fan to run while preheating during a regular bake cycle.
- The convection fan motor may run periodically during a regular bake cycle.
- If the door is left open for longer than 30 seconds during baking, the heat turns off. The heat turns back on automatically once the door is closed.

In Case of Power Failure

The oven and broiler cannot be used during a power outage. If the oven is in use when a power failure occurs, the oven burner shuts off and cannot be re-lit until power is restored. Once power is restored, you will need to reset the oven (or Broil function).

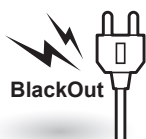

CAUTION

Do not attempt to operate the electric ignition during an electrical power failure.

Oven Vent

Areas near the vent may become hot during operation and may cause burns. Do not block the vent opening. Avoid placing plastics near the vent as heat may distort or melt the plastic.

It is normal for steam to be visible when cooking foods with high moisture content.

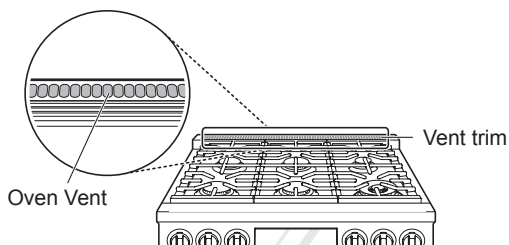

CAUTION

- The edges of the range vent and vent trim are sharp and may become hot during operation. Wear gloves when cleaning the range to avoid burns or other injury.

Using Oven Racks

The racks have a turned-up back edge that prevents them from being pulled completely out of the oven cavity.

Installing Gliding Racks

- 1 Start with the rack in the closed position. Hold the rack with one hand at the center front and the other hand at the back right corner.
- 2 Carefully insert the rack between the rack guides, and slide it back until the shelf drops into place.

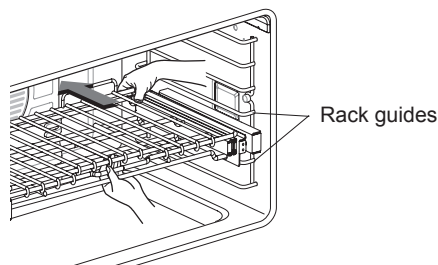

- 3 Once the rack is secured in the back, pull the entire rack forward until the rack locks into place.

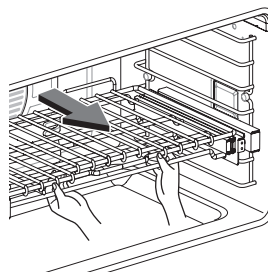

Removing Gliding Racks

- 1 With the rack in the closed position, grasp the front of the rack and frame and lift up. Slowly push the rack towards the back wall until it is free of the rack stop.
- 2 After disengaging the rack stop, lift the back of the rack and pull the rack and frame out between the rack guides.

CAUTION

- Place oven racks in the desired location before turning on the oven to avoid burns.
- Do not cover the racks with aluminum foil, or any other material, or place anything on the bottom of the oven. Doing so will result in poor baking and may damage the oven bottom.
- Do not place objects heavier than 33 lb (15 kg) on the racks. Do not place heavy objects on the corners of the racks. Doing so can damage the racks.

Accessories

Broiler Pan and Grid

Use a broiler pan and grid when preparing meats for Convection Roast and Broil.

The broiler pan catches grease spills and the grid helps prevent grease splatters.

- 1 Place the rack in the oven.
- 2 Place the grid in the broiler pan with the raised vents toward the bottom.
- 3 Place the broiler pan and grid on the rack.

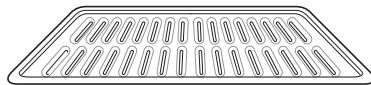

Grid

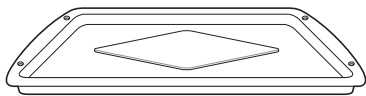

Broiler pan

CAUTION

- Do not use a broiler pan without a grid. Oil can cause a grease fire.
- Do not cover the grid and broiler pan with aluminum foil. Doing so will cause a fire.
- Always use a broiler pan and grid for excess fat and grease drainage. This will help to reduce splatter, smoke, and flare-ups.
- Do not broil meat too close to the burner flame. Trim excess fat from meat before cooking.
- Position food (fat side up) on the grid.

Oven Cooling

The oven cooling icon appears in the display if the temperature inside the oven is high during or after operation. The icon disappears if the oven temperature is below 270°F (130°C).



Timer

The oven timers don't affect oven operation or cooking time. Use them as extra kitchen timers. Once the time runs out, the oven chimes and "Timer ended" appears in the display.

Setting the Timer

- 1 Touch the clock icon  at the bottom of the display.
- 2 Scroll through the numbers in the popup until the desired time appears in the display and touch OK.

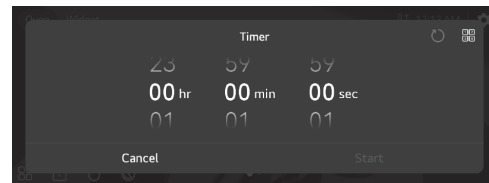

- 3 The time remaining appears next to the clock icon in the display.

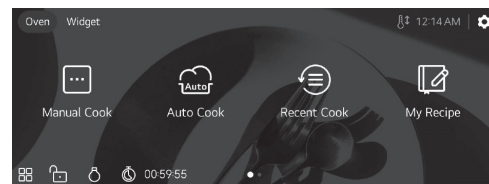

Adjusting or Cancelling the Timer

- 1 Touch the remaining time next to the clock icon in the display.
- 2 To cancel the timer, touch Stop.
- 3 To adjust the time, touch Pause and then touch Edit. Scroll the numbers in the popup until the desired time appears, then touch Restart.
- 4 The remaining time in the display is adjusted.

Bake

Bake is used to prepare foods such as pastries, breads and casseroles.

The oven can be programmed to bake at any temperature from 170 °F(80 °C) to 550 °F(285 °C). The default temperature is 350 °F(175 °C).

Setting the Bake Function

- 1 Touch **Manual Cook** in the main screen.
 - 2 Touch Temperature on the right, then Scroll through the numbers to select a cooking temperature or touch the number pad icon  to enter the numbers directly.
 - 3 If desired, set the cook time and delayed start time using the same method. Swipe the display to see the delayed start time settings.
 - 4 Touch **Start**. The oven starts to preheat.
 - 5 If the cook time is set, the remaining time appears in the display. If a delayed start time is set, the start time appears in the display.
 - 6 A chime sounds once preheating is complete.
 - 7 A chime sounds at the end of the set cook time and a notification appears in the display. Open the oven door and remove the food.
- If no cook time is set, the oven turns off automatically after 12 hours.

Changing the Cook Settings

- 1 Touch the arrow icon  at the right of the display to bring up the Cook Settings screen.
- 2 Adjust the settings using the number pad or scroll function.
- 3 Touch **Apply**.

To Stop Cooking

- 1 Touch **Stop** in the display, then select **Stop**.

NOTE

It is normal for the convection fan to operate periodically throughout a normal bake cycle in the oven. This is to ensure even baking results.

Baking Tips

- Baking time and temperature will vary depending on the characteristics, size, and shape of the baking pan used.
- When using Bake with a single rack, place the gliding rack in position 3. If cooking on multiple racks, place the gliding racks in positions 1 and 5 (for two racks).
- Check for food doneness at the minimum recipe time.
- Use metal bakeware (with or without a nonstick finish), heatproof glass-ceramic, ceramic or other bakeware recommended for oven use.
- Dark metal pans or nonstick coatings will cook food faster with more browning. Insulated bakeware will slightly lengthen the cooking time for most foods.

NOTE

The oven bottom has a porcelain-enamel finish. To make cleaning easier, protect the oven bottom from excessive spillovers by placing a foil-lined cookie sheet on the rack below the rack you are cooking on. This is particularly important when baking a fruit pie or other foods with a high acid content. Hot fruit fillings or other foods that are highly acidic may cause pitting and damage to the porcelain-enamel surface and should be wiped up as soon as it is safe to do so.

Convection Modes

Convection Bake and Convection Roast use a fan to circulate heat evenly within the oven. This improves heat distribution and allows for even cooking and excellent results whether cooking on one rack or multiple racks.

The oven can be set to Convection modes at any temperature from 300 °F(150 °C) to 550 °F (285 °C). The default temperature is 350 °F(175 °C).

Using Convection

- 1 Touch **Manual Cook** in the main screen. Then scroll through the modes to select **Convection Bake** or **Convection Roast**.
 - 2 Touch Temperature on the right, then scroll through the numbers to select a cooking temperature or touch the number pad icon  to enter the numbers directly.
 - 3 If desired, set the cook time and delayed start time using the same method. Swipe the display to see the delayed start time settings.
 - 4 Touch **Start**. The oven starts to preheat.
 - 5 If the cook time is set, the remaining time appears in the display. If a delayed start time is set, the start time appears in the display.
 - 6 A chime sounds once preheating is complete.
 - 7 A chime sounds at the end of the set cook time and a notification appears in the display. Open the oven door and remove the food.
- If no cook time is set, the oven turns off automatically after 12 hours.

Changing the Cook Settings

- 1 Touch the arrow icon  at the right of the display to bring up the Cook Settings screen.
- 2 Adjust the settings using the number pad or scroll function.
- 3 Touch **Apply**.

To Stop Cooking

- 1 Touch **Stop** in the display, then select Stop.

NOTE

The oven fan runs while convection baking. The fan stops when the door is open. In some cases, the fan may shut off during a convection bake cycle.

Tips for Convection Baking

- Use Convection Bake for faster and more even multiple-rack cooking of pastries, cookies, muffins, biscuits, and breads of all kinds.
- Bake cookies and biscuits on pans with no sides or very low sides to allow heated air to circulate around the food. Food baked on pans with a dark finish will cook faster.
- When using Convection Bake with a single rack, place the gliding rack in position 3. If cooking on multiple racks, place the gliding racks in positions 1 and 5 (for two racks).
- Multiple oven rack cooking may slightly increase cook times for some foods.
- Cakes, cookies and muffins have better results when using multiple racks.

Convection Roast

The Convection Roast feature is designed to give optimum roasting performance. Convection Roast combines cooking with the convection fan to roast meats and poultry. The heated air circulates around the food from all sides, sealing in juices and flavors. Foods are crispy brown on the outside while staying moist on the inside. Convection roasting is especially good for large tender cuts of meat, uncovered.

Recommended Baking and Roasting Guide

Baking results will be better if baking pans are centered in the oven as much as possible. If cooking on multiple racks, place the oven racks in the positions shown.

Rack and Pan Placement

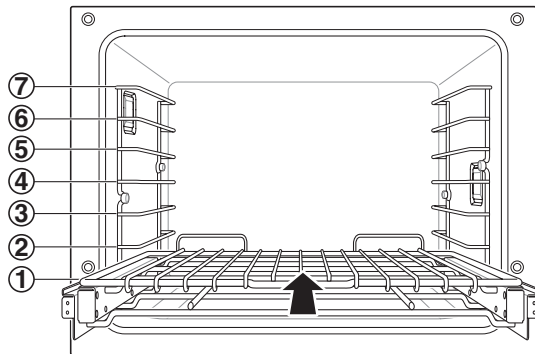

Multiple Rack Guide

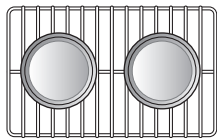

Rack
(Position 1)

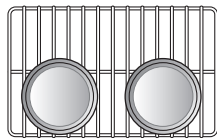

Rack
(Position 5)

Single rack baking

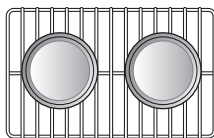

Rack

NOTE

- Cook whole chicken 60-75 minutes (until it reaches desired doneness). The USDA recommends cooking chicken to an internal temperature of at least 165°F for safe consumption.
- Brush tops of biscuits with an egg wash before cooking to improve browning.

Baking Rack Guide

	Food	Rack position
Cakes	• Layer cakes	3
	• Bundt cakes	3
Cookies	• Sugar cookies	3
	• Chocolate chips	3
	• Brownies	3
Pizza	• Fresh	4
	• Frozen	4
Pastry Crust	• From scratch	3
	• Refrigerator	3
Breads	• Biscuits, canned	3
	• Biscuits, from scratch	3
	• Muffins	3
Desserts	• Fruit crisps and cobblers, from scratch	3
	• Pies, from scratch, 2-crust fruit	3

Roasting Rack Guide

	Food	Rack position	
Beef	Rib	Rare	2
		Medium	2
		Well done	2
	Boneless rib, top sirloin	Rare	2
		Medium	2
		Well done	2
	Beef tenderloin	Rare	2
		Medium	2
	Pork	Rib	2
Bone-in, sirloin		2	
Ham, cooked		2	
Poultry	Whole chicken	2	
	Chicken pieces	4	
	Turkey	2	

Broil

The Broil function uses intense heat from the upper heating element to cook food. Broiling works best for tender cuts of meat, fish, and thinly cut vegetables.

Keep the oven door closed while broiling. Let the oven preheat for approximately five minutes before cooking food.

- For best results, use a broiler pan and grid. See **Recommended Broiling Guide** section.

Setting the Broil Function

- 1 Touch **Manual Cook** in the main screen. Then scroll through the modes to select **Broil**.
 - 2 Touch Temperature on the right, then Scroll to set the desired temperature: Low or High. If desired, scroll to set a cook time.
 - 3 Touch **Start**. The oven door must be closed to use the Broil function.
 - 4 If the cook time is set, the remaining time appears in the display. If a delayed start time is set, the start time appears in the display.
 - 5 Touch **STOP** to cancel at any time or when cooking is complete.
- If the cook time is not set, the oven automatically turns off after 3 hours.
 - Let the oven preheat for approximately five minutes before cooking the food.

Changing the Broil Settings

- 1 Touch the arrow icon ◀ at the right of the display to bring up the Cook Settings screen.
- 2 Adjust the settings.
- 3 Touch **Apply**.

To Stop Broiling

- 1 Touch **Stop** in the display, then select Stop.

NOTE

- This range is designed for closed-door broiling. Close the door to set the Broil function. If the door is open, the Broil function cannot be set and a popup appears in the display. If the door remains open for longer than 5 seconds, the broil burner turns off. Once the door is closed, the broil burner turns back on automatically.

Smoking

Due to the intense heat associated with broiling, it is normal to experience smoke during the cooking process. This smoke is a natural by-product of searing and should not cause you to worry. If you are experiencing more smoke than you are comfortable with, use the following tips to reduce the amount of smoke in your oven.

- 1 Always use a broiler pan. Do not use saute pans or regular baking sheets for safety reasons.
- 2 The broiler pan should always be thoroughly cleaned and at room temperature at the beginning of cooking.
- 3 Always run your cooktop ventilation system or vent hood during broiling.
- 4 Keep the interior of your oven as clean as possible. Leftover debris from prior meals can burn or catch fire.
- 5 Avoid fatty marinades and sugary glazes. Both of these will increase the amount of smoke you experience. If you would like to use a glaze, apply it at the very end of cooking.
- 6 If you are experiencing significant smoke with any food item, consider:
 - Lowering the broiler to the Lo setting.
 - Lowering the rack position to cook the food further away from the broiler.
 - Using the Hi broil setting to achieve the level of searing you desire, and then either switching to the Lo broil setting, or switching to the Bake function.
- 7 As a rule, fattier cuts of meat and fish will produce more smoke than leaner items.
- 8 Adhere to the recommended broil settings and cooking guidelines in the chart on the following page whenever possible.

Recommended Broiling Guide

The size, weight, thickness, starting temperature, and your preference of doneness will affect broiling times.

This guide is based on meats at refrigerator temperature. For best results when broiling, use a pan designed for broiling.

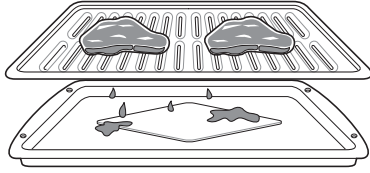

Food	Quantity and/or Thickness	Rack Position	First Side (minutes)	Second Side (minutes)	Comments
Ground Beef Well done	1 lb. (4 patties) $\frac{1}{2}$ to $\frac{3}{4}$ " thick	5	4-7	2-5	Space evenly. Up to 9 patties may be broiled at once.
Beef Steaks Rare Medium Well done	1" thick 1 to $1\frac{1}{2}$ lbs.	4 4 4	4-5 4-7 6-8	2-3 3-4 4-5	Steaks less than 1" thick cook through before browning. Pan frying is recommended. Slash fat.
Rare Medium Well done	$1\frac{1}{2}$ " thick 2 to $2\frac{1}{2}$ lbs.	4 4 4	7-9 9-11 11-13	4-6 5-7 6-8	
Chicken	1 whole cut up 2 to $2\frac{1}{2}$ lbs., split lengthwise 2 Breasts	3 3	15-17 9-11	7-9 4-6	
Lobster Tails	2-4 10 to 12 oz. each	4	14	Do not turn over	Cut through back of shell. Spread open. Brush with melted butter before broiling and after half of broiling time.
Fish Fillets	$\frac{1}{4}$ to $\frac{1}{2}$ " thick	4	6-8	3-4	Handle and turn very carefully. Brush with lemon butter before and during cooking, if desired.
Ham Slices (precooked)	$\frac{1}{2}$ " thick	4	6-8	2-4	Increase time 5 to 10 minutes per side for $1\frac{1}{2}$ " thick or home-cured ham.
Pork Chops Well done	1 ($\frac{1}{2}$ " thick) 2 (1" thick) about 1 lb.	4 4	7-9 9-11	5-7 8-10	
Lamb Chops Medium Well done	2 (1" thick) about 10 to 12 oz.	4 4	6-8 8-10	3-4 4-5	
Medium Well done	2 ($1\frac{1}{2}$ " thick) about 1 lb.	4 4	9-11 11-13	5-6 6-8	
Salmon Steaks	2 (1" thick) 4 (1" thick) about 1 lb.	4 4	6-8 7-9	5-7 5-7	Grease pan. Brush steaks with melted butter.

- This guide is only for reference. Adjust cook time according to your preference.
- For best performance, center food on rack when using Broil.

Tips for Broiling

Beef

- Steaks and chops should always be allowed to rest for five minutes before being cut into and eaten. This allows the heat to distribute evenly through the food and creates a more tender and juicy result.
- Pieces of meat that are thicker than two inches should be removed from the refrigerator 30 minutes prior to cooking. This will help them cook more quickly and evenly, and will produce less smoke when broiling. Cooking times will likely be shorter than the times indicated in the Broiling Chart.
- For bone-in steaks or chops that have been *frenched* (all meat removed from around the bone), wrap the exposed sections of bone in foil to reduce burning.

Seafood

- When broiling skin-on fish, always use the Lo broil setting and always broil the skin side last.
- Seafood is best consumed immediately after cooking. Allowing seafood to rest after cooking can cause the food to dry out.
- It is a good idea to rub a thin coating of oil on the surface of the broiling pan before cooking to reduce sticking, especially with fish and seafood. You can also use a light coating of non-stick pan spray.

Vegetables

- Toss your vegetables lightly in oil before cooking to improve browning.

Warm

The Warm mode maintains an oven temperature of 200°F or less. Use the Warm mode to keep cooked food at serving temperature for up to three hours after the end of the cooking cycle. Do not use the Warm mode to try to cook food or reheat cold food.

Setting the Warm Function

- 1 Touch **Manual Cook** in the main screen. Then scroll through the modes to select **Warm**.
 - 2 Touch Temperature on the right, then Scroll to set the desired temperature: Low, Medium, or High. If desired, scroll to set a run time.
 - 3 Touch **Start**.
 - 4 If the run time is set, the remaining time appears in the display. If a delayed start time is set, the start time appears in the display.
- If the run time is not set, the Warming function turns off automatically after 3 hours.

NOTE

- The warm feature has three temperature levels: High=200 °F, Med=170 °F, Low=140 °F
High=93 °C, Med=77 °C, Low=60 °C

Changing the Warm Settings

- 1 Touch the arrow icon ◀ at the right of the display to bring up the Cook Settings screen.
- 2 Adjust the settings as desired.
- 3 Touch **Apply**.

Canceling the Warm Function

- 1 Touch **Stop** in the display, then select Stop.

NOTE

- The Warm function is intended to keep food warm. Do not use it to cool food down.
- It is normal for the fan to operate during the Warm function.

Keep Warm

This function will maintain an oven temperature of 170 °F. The Keep Warm function will keep cooked food warm for serving up to 3 hours after cooking has finished. The Keep Warm function should be used with any other cooking operations. The Keep Warm function can be used after cooking has finished using a Timed Cook or a Delayed Timed Cook.

Setting the Keep Warm Function after a Timed Cook

- 1 Touch **Manual Cook** in the main screen. Then scroll through the modes to select **Bake, Conv. Bake, Conv. Roast, Broil, Air Fry, Air Roast, Pizza, Frozen Meal, or Crispy Reheat**.
- 2 Set the oven temperature and cook time.
- 3 Swipe the display and touch the **When Finished** setting, then scroll to select **Keep Warm**.
- 4 Touch **Start**. When the set cook time ends, the Keep Warm function automatically turns on.
- 5 To cancel the Keep Warm function, touch **Stop** in the display, then select Stop.

NOTE

- Even if the **When Finished** setting was not selected before starting the Cook mode, you can activate this function by touching **Keep Warm** on the screen after the cooking is complete.

Air Fry

This feature automatically increases the entered temperature by 50 °F for optimal performance when using Air Fry.

The Air Fry function is specially designed for oil-free frying.

Setting the Air Fry Function

- 1 Touch **Manual Cook** in the main screen. Then scroll through the modes to select **Air Fry**.
- 2 Set the oven temperature.
(Range: 300 °F ~ 550 °F)
- 3 Touch **Start**.
- 4 Touch **STOP** to cancel at any time or when cooking is complete.

NOTE

- No preheating is required when using the Air Fry mode.
- If cooking multiple batches, the later batches may take less time to cook.
- Wet batters and coatings will not crisp or set when using the Air Fry mode.

Tips for Air Fry

- For best results, use the provided air fry tray.
 - The air fry tray can be cleaned in a dishwasher.

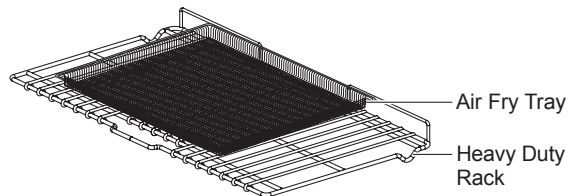

- If you don't have the air fry tray, place food on a wire rack inside a foil-lined broiler pan.

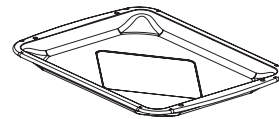

Broiler Pan

- For best results, cook food on a single rack placed in the positions suggested in the chart in this manual.
- Spread the food out evenly in a single layer.
- Use either the provided air fry tray or a dark baking tray with no sides or short sides that does not cover the entire rack. This allows for better air circulation.
- If desired, spray the baking tray or air fry tray with a pan spray. Use an oil that can be heated to a high temperature before smoking, such as avocado, grapeseed, peanut or sunflower oil.
- Place a foil-lined baking tray on a rack in position 1 to catch the oil falling from the food. For high-fat foods like chicken wings, add a few sheets of parchment paper to absorb the fat.
- Check food often and shake it or turn it over for crisper results.
- Prepared frozen foods may cook faster with the Air Fry mode than stated on the package. Reduce the cooking time by about 20 percent, check food early, and adjust cooking time as needed.
- Use a food thermometer to make sure food has reached a safe temperature for consumption. Eating undercooked meats can increase your risk of food-borne illness.
- For the crispiest results, dredge fresh chicken wings or tenders in seasoned flour. Use 1/3 cup flour for 2 pounds of chicken.

Recommendations When Air Frying High-Fat Foods

Foods high in fat will smoke when using the Air Fry mode. For best results, follow these recommendations when air frying foods that are high in fat, such as chicken wings, bacon, sausage, hot dogs, turkey legs, lamb chops, ribs, pork loin, duck breasts, or some plant-based proteins.

CAUTION

- Never cover slots, holes, or passages in the oven bottom or cover entire racks with materials such as aluminum foil. Doing so blocks airflow through the oven and can result in carbon monoxide poisoning. Aluminum foil can also trap heat, causing a fire hazard or poor oven performance.
- Clean the grease filters on your exhaust hood regularly.

- Turn on your exhaust hood at a high fan setting before you start Air Fry and leave it on for 15 minutes after you're done.
- Open a window or sliding glass door, if possible, to make sure the kitchen is well-ventilated.
- Keep the oven free from grease buildup. Wipe down the interior of the oven before and after air frying (once the oven has cooled).
- Run oven cleaning cycles (**EasyClean** or **SelfClean**) regularly, depending on how often and what types of food you **Air Fry**.
- Avoid opening the oven door more than necessary to help maintain the oven temperature, prevent heat loss, and save energy.
- Air-frying fresh chicken pieces such as wings or drumsticks with the skin left on can produce smoke as the fat renders at high temperatures. If the smoke is excessive, use the Convection Roast mode instead of Air Fry.

Recommended Air Frying Guide

- Arrange food evenly in a single layer.
- Put a foil-lined baking pan on a rack in position 1 to catch drips. If needed, add parchment paper to absorb oil and reduce smoking.
- Flip food over during cooking to avoid burning it.

† High-fat items may produce more smoke when cooked using Air Fry. For less smoke, cook using Convection Roast mode.

Recommended Items	Quantity (oz)	Temp. (°F)	Rack Position	Time	Guide
POTATOES-Frozen					
Frozen French Fries (Shoestring)	20	425	3	15-25	
Frozen French Fries (Crinkle cut, 3/8" or 10 mm)	35	425	3	15-35	
Frozen Sweet Potato Fries	25	425	3	15-30	
Frozen Tater Tots	50	450	3	20-30	
Frozen Hash Browns	40	425	3	20-30	
POTATOES-Fresh/Homemade					
Homemade French Fries (3/8" x 3/8" or 10 x 10 mm)	25	450	3	15-25	Cut the potatoes and soak for 30 minutes in hot tap water. Drain and pat dry. Brush or lightly spray with 3 tbsp. of oil. Add salt and pepper to taste.
Homemade Potato Wedges	60	450	3	20-30	

48 OPERATION

Recommended Items	Quantity (oz)	Temp. (°F)	Rack Position	Time	Guide
CHICKEN-Frozen					
Frozen Chicken Nuggets, Crispy	30	400	3	20-30	
Frozen Chicken Strips	35	400	3	25-35	
Frozen Hot Wings, Bone-in	50	425	3	20-30	
CHICKEN-Fresh, Skin on					
Fresh Chicken Wings [†]	40	450	3	20-30	Brush or lightly spray with 1 tbsp. of oil. Add salt and pepper to taste.
Fresh Chicken Drumsticks [†]	70	450	3	25-35	
Thighs	40	450	3	25-35	
Breasts	40	450	3	25-35	
OTHER					
Frozen Onion Rings, Breaded	20	400	3	15-25	
Frozen Spring Rolls (0.7 oz. each)	45	425	3	15-25	
Thin Sausage [†] (2.5 oz. each, diameter 0.8")	90	400	3	15-25	
Frozen Coconut Shrimp	25	425	3	20-30	Brush or lightly spray the surface of food with oil.
Fresh Scallops on the half shell (35 oz.)	35	425	3	15-25	Melt 4 tbsp. of butter and brush on scallops. Mix 1/2 cup bread crumbs, 1 tbsp. minced garlic, 1/4 cup grated parmesan cheese and season to taste. Sprinkle mixture over scallops.
Fresh Shrimp	50	425	3	20-30	
Mixed Vegetables	35	425	3	20-30	Brush or lightly spray with 4 tbsp. of olive oil. Add salt and pepper to taste.

Air Sous-Vide

Air Sous-Vide cooking uses air to cook foods “low and slow.” Use it to cook meat, fish, seafood, poultry or vegetables. Food must be vacuum packed in pouches before cooking.

- It is not necessary to preheat the oven when using Air Sous-Vide.
- Refer to the cooking guide for recommended Air Sous-Vide settings.

Benefits of Air Sous-Vide

The lower temperatures and long cooking times used in Air Sous-Vide cooking provide many benefits.

- Healthier
 - Compared to other cooking methods, Air Sous-Vide retains most of the original nutrients in food.
- Safe and Convenient
 - The long cooking times used in Air Sous-Vide cooking allow food to be pasteurized. Because food is vacuum packed before cooking, the unopened pouches can be quickly chilled in an ice bath and stored in the freezer or refrigerator after cooking.
- Crisp and Moist Results
 - The fine temperature control of Air Sous-Vide cooking is an excellent way to achieve the perfect texture when cooking meat and poultry. The low temperatures used retain more of the moisture in food than conventional cooking methods. After cooking, a final sear in a frying pan adds the perfect crisp finish.

Setting Air Sous-Vide Mode

- 1 Place the heavy duty rack in position 3 and place the sealed food bag on it.
- 2 Touch **Manual Cook** in the main screen. Then scroll through the modes to select **Air Sous-Vide**.
- 3 Set the desired oven temperature. (Range: 100 °F ~ 205 °F)
- 4 Touch **Start**.
- 5 Touch **STOP** to cancel at any time or when cooking is complete.

Recommended Air Sous-Vide Guide

Food	Quantity	Rack Position	Temp. (°F)	Time		
				Min.	Target	Max.
Beef Steaks	1" thick 14 - 17 oz.	3	135	-	2.5 hr.	3 hr.
Chicken	Breasts	3	150	-	2 hr.	3 hr.
	Thighs (bone-in)	3	155	-	4 hr.	6 hr.
Salmon	1" thick 5 - 7 oz.	3	140	-	2 hr.	2.5 hr.
Vegetables	Asparagus	3	185	20 min.	30 min.	45 min.
	Potatoes	3	200	-	2.5 hr.	-
	Carrots	3	200	1.5 hr.	2 hr.	3 hr.

Air Roast

This function enables quick and even roasting of chicken or vegetables without pre-heating.

Setting the Air Roast Function

- 1 Touch **Manual Cook** in the main screen. Then scroll through the modes to select **Air Roast**.
- 2 Set the oven temperature and cook time.
- 3 Touch **Start**.
- 4 Touch **Stop** to cancel at any time or when cooking is complete.

Pizza

This function is a dedicated cooking mode for pizza, providing optimal heat to crisp the crust while evenly cooking the toppings.

Setting the Pizza Function

- 1 Touch **Manual Cook** in the main screen. Then scroll through the modes to select **Pizza**.
- 2 Set the oven temperature and cook time.
- 3 Touch **Start**. The oven starts to preheat.
- 4 Touch **Stop** to cancel at any time or when cooking is complete.

Dehydrate

This function removes moisture at a low temperature over an extended period, allowing fruits and vegetables to be made into dried snacks such as apple chips, banana chips, and dried tomatoes.

Setting the Dehydrate Function

- 1 Touch **Manual Cook** in the main screen. Then scroll through the modes to select **Dehydrate**.
- 2 Set the oven temperature and cook time.
- 3 Touch **Start**.
- 4 Touch **Stop** to cancel at any time or when cooking is complete.

Crispy Reheat

This function helps restore the crisp texture of pre-cooked food that has become soggy over time.

Setting the Crispy Reheat Function

- 1 Touch **Manual Cook** in the main screen. Then scroll through the modes to select **Crispy Reheat**.
- 2 Set the oven temperature and cook time.
- 3 Touch **Start**. The oven starts to preheat.
- 4 Touch **Stop** to cancel at any time or when cooking is complete.

Frozen Meal

The Frozen Meal function is specially designed for cooking frozen prepared meals. It heats from both the top and bottom to brown food more evenly.

This system is designed to give the optimum cooking performance by automatically selecting a combination of the broil and bake heating systems. No preheating is required when using the Frozen Meal mode. For best results with frozen pizza, cook food on a single rack placed in position 4 at 400 °F.

Setting the Frozen Meal Function

- 1 Touch **Manual Cook** in the main screen. Then scroll through the modes to select **Frozen Meal**.
- 2 Set the suggested cook temperature from the packaging using the number buttons or scroll through the numbers to select a cooking temperature. (Range: 300 °F ~ 550 °F)
- 3 Press **START**. The Frozen Meal function starts operation.
- 4 Touch **STOP** to cancel at any time or when cooking is complete.

Proof

This feature maintains a warm oven for rising yeast leavened products before baking.

Setting the Proof Function

- 1 Touch **Manual Cook** in the main screen. Then scroll through the modes to select **Proof**.
- 2 Scroll through the numbers to set a proofing time or touch the number pad icon  to enter the numbers directly.
- 3 Touch **Start**. The remaining proofing time appears in the display.
- 4 If the proofing time is set, the remaining time appears in the display. If a delayed start time is set, the start time appears in the display.

- If the proofing time is not set, the oven automatically turns off after 12 hours.

Canceling the Proof Function

- 1 Touch **Stop** in the display, then select Stop.

NOTE

- To avoid lowering the oven temperature and lengthening proofing time, do not open the oven door unnecessarily. Check bread products early to avoid over proofing.
- Do not use the proofing mode for warming food or keeping food hot. The proofing oven temperature is not hot enough to keep foods at safe temperatures. Use the Warm feature to keep food warm. Proofing does not operate when the oven is above 125 °F. “**Oven is too hot**” appears in the display.
- It is normal for the fan to operate during the Proof function.

Probe

The probe accurately measures the internal temperature of meat, poultry and casseroles. Always unplug and remove the probe from the oven when removing food. Before using, insert the probe into the center of the thickest part of the meat or into the inner thigh or breast of poultry, away from fat or bones. Place the food in the oven and connect the probe to the jack. Keep the probe as far away from heat sources as possible.

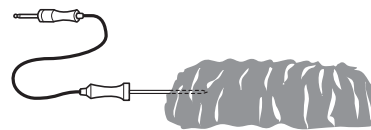

- The probe cannot be used in Broil, Air Fry, Air Sous-Vide, Pizza, Frozen Meal, Dehydrate, Warm, Proof or Crispy Reheat modes.
- For thin cuts of meat, insert the probe in the thickest side of the meat.



Recommended Probe Placement Chart

Category	Examples of Food	Probe Placement
Ground Meat & Meat Mixtures	Meatloaf	Insert in the thickest part
	Meatballs	
Fresh Beef, Veal, Lamb	Steaks, Roasts, Chops	Insert in the thickest part, away from bone, fat and gristle
Poultry	Whole Chicken or Turkey	Insert in the thickest part of thigh, avoiding bone
	Poultry Breasts or Roasts	
	Duck, Goose, Pheasant	
	Stuffing (Alone or in Bird)	Insert in the thickest part of the dish
Pork & Ham	Fresh Pork	Insert in the thickest part, away from bone, fat and gristle
	Fresh Ham (Raw)	
	Precooked Ham (Reheat & Serve)	
Leftovers & Casseroles	Leftovers	Insert in the thickest part of the dish
	Casseroles	
Seafood	Whole Fish	Insert in the thickest part of the fish
	Fish Fillet (Side of Fish)	
	Fish Steaks or Portions	

Using the Probe

- 1 Insert the probe into the food.
- 2 Connect the probe to the jack in the oven, and "Probe is connected" pops up in the display and the probe icon  appears at the top of the display.
- 3 Touch **Manual Cook** in the main screen. Then touch an appropriate cooking mode. Swipe the display to see **Probe**.
- 4 Scroll through the numbers to set a cooking temperature and a probe temperature or touch the number pad icon  to enter the numbers directly. The default probe temperature is 150 °F (65 °C), but can be changed to any temperature between 80 °F (27 °C) and 210 °F (100 °C).
- 5 If desired, set the delayed start time using the same method. Swipe the display to see the additional settings.
- 6 Touch **Start**. If a delayed start time has been set, the start time appears in the display.
- 7 When the set probe temperature is reached, the oven shuts off automatically.

Changing the Cook Settings

- 1 Touch the arrow icon  at the right of the display to bring up the Cook Settings screen.
- 2 Adjust the settings as desired.
- 3 Touch **Apply**.

To Stop Cooking

- 1 Touch **Stop** in the display, then select Stop.

IMPORTANT NOTE

Touch Stop on the display at any time to cancel a cooking operation. To avoid breaking the probe, make sure food is completely defrosted before inserting.

CAUTION

- **Always use an oven mitt to remove the temperature probe. Do not touch the broil element.** Failure to obey this caution can result in severe personal injury.
- **To avoid damage to the meat probe, do not use tongs to pull on the probe when removing it.**
- **Do not store the meat probe in the oven.**
- **The accuracy of the temperature reading depends entirely on probe placement. For precise results, ensure the tip is inserted into the thickest part of the food, away from fat, bone, or gristle. If the probe is inserted too shallowly or touches a heating surface, it may provide a false reading, leading to undercooked or overcooked food. Always verify internal temperatures in multiple spots using a secondary food thermometer to ensure food safety.**

Recommended Probe Temperature Chart

Category	Examples of Food	Target Internal Temp.	Desired Doneness
Ground Meat & Meat Mixtures	Meatloaf	160 °F (71 °C)	
	Meatballs	165 °F (74 °C)	
Fresh Beef, Veal, Lamb	Steaks, Roasts, Chops	145 °F (63 °C)	Rare: 130 °F (54 °C) Medium Rare: 140 °F (60 °C) Medium: 150 °F (66 °C) Well Done: 160 °F (71 °C)
Poultry	Whole Chicken or Turkey	165 °F (74 °C)	
	Poultry Breasts or Roasts		
	Duck, Goose, Pheasant		
	Stuffing (Alone or in Bird)		
Pork & Ham	Fresh Pork	145 °F (63 °C)	Well Done: 170 °F (77 °C)
	Fresh Ham (Raw)		Well Done: 160 °F (71 °C)
	Precooked Ham (Reheat & Serve)	140 °F (60 °C)	
Leftovers & Casseroles	Leftovers	165 °F (74 °C)	Cook for 45-60 minutes or until desired doneness
	Casseroles		
Seafood	Whole Fish	145 °F (63 °C)	
	Fish Fillet (Side of Fish)		
	Fish Steaks or Portions		Well Done: 160 °F (71 °C)

My Recipe

For frequently used cooking menus, you can combine up to three different temperatures and cooking modes into one hot key.

Creating My Recipe

- When combining two or more cooking modes, a cooking time or probe temperature must be set before selecting an additional cooking mode.
 - The Probe function cannot be used with the Broil, Warm or Proof modes.
- 1 Touch **My Recipe** in the main screen.
 - 2 Touch **Create** to make a new hot key.
 - 3 Select a first cook mode listed in the display and set the desired temperature and cook time.
 - 4 If there are no additional cooking stages, touch **Done**. To add another cooking stage, set a cooking time or probe temperature for the first stage. Then touch **Add Stage**.
 - 5 Repeat steps 3-4 until all desired cooking stages have been entered. Then touch **Done**.
 - 6 Enter a name for your recipe using the keyboard and touch **Save**.
 - 7 The recipe name is added to the My Recipes menu.

NOTE

- If the probe was inserted in the oven jack to add a probe temperature, remember to remove it.

Editing My Recipe

- The Edit function cannot add or remove cooking stages to a recipe. Only the oven temperature, probe temperature and cook time can be changed.
- 1 Touch **My Recipe** in the main screen.
 - 2 Select the recipe to edit then touch the pencil icon  at the bottom left of the screen.
 - 3 Edit the settings for the first cooking stage and touch **Done** to proceed to the next cooking stage, if any.
 - 4 Edit the next cooking stage, touch **Done**, and proceed through all cooking stages in the same way.
 - 5 Once the last cooking stage has been edited, enter a new name for the recipe or keep the previous name, then touch **Save**.

Deleting My Recipe

- 1 Touch **My Recipe** in the Cooking Modes screen.
- 2 Select the recipe and touch the trash can icon  at the bottom left of the screen.
- 3 Touch **Delete**.

Recent Cook

Use this function to quickly access recently used cooking modes.

Remote Start

If the appliance is registered on a home Wi-Fi network, the preheating function of the oven can be started or stopped using the LG ThinQ smartphone app.

Preparing the Oven for a Remote Start

- 1 Open the oven door to make sure the oven is empty and ready for preheating. Do not place food in the oven. Close the oven door. Remote Start can only be set when the oven door is closed.
- 2 Touch the settings icon  at the top right of the Main screen. Touch the toggle switch next to **Remote Start**.
- 3 Follow the instructions in the LG ThinQ smartphone app for using the Remote Start function.

NOTE

- Remote Start is disconnected in the following situations:
 - Remote Start is never set up in the smart phone app.
 - Remote Start experiences a problem during operation.
- The Wi-Fi icon on the display shows the status of the appliance's network connection. If the Wi-Fi icon is not lit, use the smartphone app to select the Wi-Fi network or connect the product again.
- A faulty Wi-Fi connection could delay the Remote Start function.
- Disconnect the probe if attached.

Auto Cook Mode

The Auto Cook function provides guidance for cooking foods or dishes that may be unfamiliar. It contains preset programs for cooking many popular food items, with information on recommended preheating, accessories, and rack position for optimal results.

Setting Auto Cook Mode

- 1 Touch **Auto Cook** in the main screen.
- 2 Swipe or tap the letters to find and select an item.
- 3 Follow the recommendations in the display regarding accessories and rack position.
- 4 Touch **Start**.

Auto Cook Guide

- Preheat oven first for most items.
- Preheat for 5 minutes when broiling.
- If using probe, insert food and probe before preheating.

NOTE

- When cooking thin cuts of meat, insert the probe into the thickest part of the meat. If the probe is inserted incorrectly, the oven could turn off too soon. See the Probe section for instructions.

† Probe connection required in this menu. Connect the probe properly.

Beef			
Menu	Amount	Food Temp.	Instructions
	Cookware	Rack Position	
Beef Tenderloin †	2-4 lb.	Refrigerated	Ingredients Kosher salt, ground black pepper, garlic powder to taste
	Grid on broiler pan	2	Instructions Prepare beef tenderloin, trimmed. Brush or lightly spray with oil. Add salt, garlic powder and pepper to taste. Place the tenderloin on the grid on the broiler pan.
Roast Beef †	2-4 lb.	Refrigerated	Ingredients Kosher salt, ground black pepper, garlic powder to taste
	Grid on broiler pan	2	Instructions Prepare beef sirloin, trimmed. Brush or lightly spray with oil. Add salt, garlic powder and pepper to taste. Place the sirloin on the grid on the broiler pan.
Prime Rib †	8-12 lb.	Refrigerated	Ingredients Kosher salt, ground black pepper, garlic powder to taste
	Roasting pan	2	Instructions Prepare the bone-in prime rib. Brush or lightly spray with oil. Add salt, garlic powder and pepper to taste. Place the prime rib in the roasting pan.

Pork			
Menu	Amount	Food Temp.	Instructions
	Cookware	Rack Position	
Pork Ribs	2-4 lb.	Refrigerated	Ingredients Kosher salt, ground black pepper to taste
	Grid on broiler pan	2	Instructions Prepare bone-in pork ribs, trimmed. Brush or lightly spray with oil. Add salt and pepper to taste. Place the pork ribs on the grid on the broiler pan.
Pork Chops	1-6 EA	Refrigerated	Ingredients Kosher salt, ground black pepper to taste
	Grid on broiler pan	4	Instructions Prepare bone-in pork chops, about 6 oz. each, trimmed. Brush or lightly spray with oil. Add salt and pepper to taste. Place the pork chops on the grid on the broiler pan.

Pork			
Menu	Amount	Food Temp.	Instructions
	Cookware	Rack Position	
Pork Loin†	2-4 lb.	Refrigerated	<p>Ingredients Kosher salt, ground black pepper to taste</p> <p>Instructions Prepare pork loin, about 4 inches in diameter, trimmed. Brush or lightly spray with 1 tbsp. of oil. Add salt and pepper to taste. Place the pork loin on the grid on the broiler pan.</p>
	Grid on broiler pan	2	
Pork Tenderloin†	2-4 lb.	Refrigerated	<p>Ingredients Kosher salt, ground black pepper to taste</p> <p>Instructions Prepare pork tenderloin, 2~3 inches in diameter, trimmed. Brush or lightly spray with 1 tbsp. of oil. Add salt and pepper to taste. Place the tenderloin on the grid on the broiler pan.</p>
	Grid on broiler pan	2	

Lamb			
Menu	Amount	Food Temp.	Instructions
	Cookware	Rack Position	
Rack of Lamb†	2-4 lb.	Refrigerated	<p>Ingredients Canola oil, kosher salt, ground black pepper to taste</p> <p>Instructions Prepare rack of lamb, trimmed. Brush or lightly spray with 1 tbsp. of oil. Add salt and pepper to taste. Place the rack of lamb on the grid on the broiler pan.</p>
	Grid on broiler pan	2	
Bone-in Leg of Lamb†	5-7 lb.	Refrigerated	<p>Ingredients Canola oil, kosher salt, ground black pepper to taste</p> <p>Instructions Prepare bone-in leg of lamb, trimmed. Brush or lightly spray with 1 tbsp. of oil. Add salt and pepper to taste. Place the leg of lamb in the roasting pan.</p>
	Roasting Pan	2	

Sausage			
Menu	Amount	Food Temp.	Instructions
	Cookware	Rack Position	
Italian Sausage	1-8 EA	Refrigerated	<p>Prepare sausage, about 3.5 oz. each. Spray a rimmed sheet pan with cooking spray. Place the Italian sausages on the half sheet pan and space the sausages 1½ in. apart from each other. When oven beeps, turn the Italian sausages over.</p>
	1/2 Sheet Pan	4	
Hot Dogs	1-8 EA	Refrigerated	<p>Prepare hot dogs, about 2 oz. each. Spray a rimmed sheet pan with cooking spray. Place the hot dogs on the half sheet pan and space the hot dogs 1½ in. apart from each other. When oven beeps, turn the hot dogs over.</p>
	1/2 Sheet Pan	4	

Fish			
Menu	Amount	Food Temp.	Instructions
	Cookware	Rack Position	
Fish Fillet	1-4 EA	Refrigerated	<p>Ingredients Kosher salt, ground black pepper, oil to taste</p> <p>Instructions Prepare the fish fillet, about 7 oz. each, and about 1~1.5 in. thick. Brush or lightly spray with oil. Add salt and pepper to taste. Place the fillet on the grid on the broiler pan.</p>
	Grid on broiler pan	4	
Cod Fillet	1-4 EA	Refrigerated	<p>Ingredients Kosher salt, ground black pepper, oil to taste</p> <p>Instructions Prepare the cod fillet, about 7 oz. each, and about 1~1.5 in. thick. Brush or lightly spray with oil. Add salt and pepper to taste. Place the fillet on the grid on the broiler pan.</p>
	Grid on broiler pan	4	
Salmon Fillet	1-4 EA	Refrigerated	<p>Ingredients Kosher salt, ground black pepper, oil to taste</p> <p>Instructions Prepare the salmon fillet, about 7 oz. each, and 3/4 in. thick. Brush or lightly spray with oil. Add salt and pepper to taste. Place the fillet on the grid on the broiler pan.</p>
	Grid on broiler pan	4	
Baked Shrimp	1-2 lb.	Refrigerated	<p>Ingredients Kosher salt, ground black pepper, oil to taste</p> <p>Instructions Prepare the shrimp, peel and devein (if necessary). Brush or lightly spray with oil. Add salt and pepper to taste. Place the shrimp on the grid on the broiler pan.</p>
	Grid on broiler pan	4	
Tilapia Fillet	1-4 EA	Refrigerated	<p>Ingredients Kosher salt, ground black pepper, oil to taste</p> <p>Instructions Prepare the tilapia fillet, about 7 oz. each, and about 1~1.5 in. thick. Brush or lightly spray with oil. Add salt and pepper to taste. Place the fillet on the grid on the broiler pan.</p>
	Grid on broiler pan	4	
Lobster Tails	1-2 EA	Refrigerated	<p>Ingredients Salt, pepper to taste, 1 Tbsp butter - melted</p> <p>Instructions Prepare the lobster tails, about 5 oz. each Butterfly the lobster tails. Brush with melted butter. Add salt to taste. Place the lobster tails on the grid on the broiler pan.</p>
	Grid on broiler pan	4	

Fish			
Menu	Amount	Food Temp.	Instructions
	Cookware	Rack Position	
Salmon Steak	1-4 EA	Refrigerated	Ingredients Kosher salt, ground black pepper, oil to taste
	Grid on broiler pan	4	Instructions Prepare the salmon steak, about 7 oz. each, and about 1.5~2 in. thick. Brush or lightly spray with oil. Add salt and pepper to taste. Place the salmon on the grid on the broiler pan.
Tuna Steak	1-4 EA	Refrigerated	Ingredients Salt, pepper, oil to taste
	Grid on broiler pan	4	Instructions Prepare the tuna steak, about 7 oz. each, and about 1.5~2 in. thick. Brush or lightly spray with oil. Add salt and pepper to taste. Place the tuna on the grid on the broiler pan.

Poultry			
Menu	Amount	Food Temp.	Instructions
	Cookware	Rack Position	
Spatchcock Chicken†	4-6 lb / chicken	Refrigerated	Ingredients Kosher salt, ground black pepper, to taste
	Grid on broiler pan	2	Instructions Prepare the chicken, about 4~6 lb. Spatchcock the chicken by removing the backbone. Add salt, pepper and herbs to taste. Place the chicken with the skin side up on the grid on the broiler pan.
Chicken Drumsticks	4-16 EA	Refrigerated	Ingredients Kosher salt, ground black pepper, oil to taste
	Grid on broiler pan	4	Instructions Prepare the chicken drumsticks, about 4 oz. each. Brush or lightly spray with oil. Add salt and pepper to taste. Place the chicken drumsticks on the grid on the broiler pan.
Fresh Chicken Wings	10-20 EA	Refrigerated	Ingredients Salt, pepper, oil to taste
	Grid on broiler pan	4	Instructions Prepare the fresh chicken wings, about 3 oz. each. Brush or lightly spray with oil. Add salt and pepper to taste. Place the fresh chicken wings on the grid on the broiler pan.
Frozen Buffalo Wings	10-20 EA	frozen	Ingredients Kosher salt, ground black pepper, oil to taste
	Grid on broiler pan	4	Instructions Prepare the frozen buffalo wings, about 3 oz. each. Add salt and pepper to taste, if necessary. Place the frozen buffalo wings on the grid on the broiler pan.

Poultry			
Menu	Amount	Food Temp.	Instructions
	Cookware	Rack Position	
Frozen Chicken Wings (Raw)	10-20 EA	frozen	Ingredients Kosher salt, ground black pepper, oil to taste
	Grid on broiler pan	4	Instructions Prepare the frozen chicken wings, about 3 oz. each. Add salt and pepper to taste, if necessary. Place the frozen chicken wings on the grid on the broiler pan.
Chicken Breasts	1-8 EA	Refrigerated	Ingredients Kosher salt, ground black pepper, oil to taste
	Grid on broiler pan	4	Instructions Prepare the fresh chicken breasts, about 6 oz. each. Brush or lightly spray with oil. Add salt and pepper to taste. Place the chicken breasts on the grid on the broiler pan.
Whole Chicken†	5-7 lb / chicken	Refrigerated	Ingredients Kosher salt, ground black pepper, to taste
	Grid on broiler pan	2	Instructions Prepare the whole chicken, about 5~7 lb. Truss the chicken. Add salt and pepper to taste. Place the whole chicken on the grid on the broiler pan.
Turkey Breasts†	1-4 EA	Refrigerated	Ingredients Kosher salt, ground black pepper, oil to taste
	Grid on broiler pan	2	Instructions Prepare the turkey breasts, about 3 lb. each. Brush or lightly spray with oil. Add salt and pepper to taste. Place the turkey breasts on the grid on the broiler pan.
Whole Turkey†	12-16 lb.	Refrigerated	Ingredients Kosher salt, ground black pepper, to taste
	Roasting Pan	1	Instructions Prepare the whole turkey, about 12~16 lb. Add salt and pepper to taste. Place the whole turkey in the roasting pan.
Turkey with Stuffing†	12-16 lb.	Refrigerated	Ingredients Kosher salt, ground black pepper, to taste
	Roasting Pan	1	Instructions Prepare the turkey, about 12~16 lb. Add stuffing to the cavity of the turkey. Add salt and pepper to taste. Place the turkey with stuffing in the roasting pan.
Spatchcock Turkey†	7-12 lb.	Refrigerated	Ingredients Kosher salt, ground black pepper, to taste
	Roasting Pan	2	Instructions Prepare the turkey, about 7~12 lb. Spatchcock the turkey by removing the backbone. Add salt, pepper and herbs to taste. Place the turkey with the skin side up in the roasting pan.

Casserole			
Menu	Amount	Food Temp.	Instructions
	Cookware	Rack Position	
Homemade Lasagna	1 casserole (Serves 6)	Room	<p>Ingredients</p> <p>1 lb. ground beef, cooked 32 oz ricotta cheese 2 cups mozzarella cheese ½ cup grated parmesan cheese 2 eggs 2 24-oz jars tomato sauce 1 box no-boil lasagna sheets</p> <p>Instructions</p> <p>Serves 6</p> <ol style="list-style-type: none"> 1. Combine the ricotta cheese, 1 cup of mozzarella cheese and ¼ cup of parmesan cheese in a bowl. Add the eggs and combine. 2. Spread 1 cup of tomato sauce on the bottom of the baking dish. 3. Lay down 4 lasagna sheets, then 1 cup tomato sauce and ½ of the ricotta cheese mixture. Top with half of the cooked meat 4. Repeat step 3. 5. Top with 4 more lasagna sheets and the remaining tomato sauce. 6. Sprinkle with the remaining mozzarella and parmesan cheeses. 7. Cover with foil while preheating . 8. After preheating, place the covered baking dish on the rack. 9. When the oven beeps, remove the foil. 10. Continue baking until cooking is complete.
	13 x 9 inch baking dish	4	

Casserole			
Menu	Amount	Food Temp.	Instructions
	Cookware	Rack Position	
Homemade Mac & Cheese	1 casserole (Serves 6)	Room	<p>Ingredients</p> <p>Bread Crumb Topping 1 cup panko bread crumbs 2 tbsp unsalted butter, melted</p> <p>Macaroni 1 pound elbow macaroni pasta</p> <p>Cheese Sauce 4 Tbsp unsalted butter 1/3 cup all-purpose flour 1 tsp ground mustard 1 tsp ground paprika 5 cups half and half 4 oz processed cheese 12 oz sharp white cheddar cheese, shredded 4 oz smoked gouda cheese, shredded 1 tsp Sriracha sauce</p> <p>Instructions Serves 6 Bread Crumb Topping 1. In a bowl, combine the bread crumbs and the melted butter; set aside.</p>
	13 x 9 inch Baking dish	3	<p>Macaroni 1. Cook the pasta in a large pot of boiling, salted water until al dente, according to the package recommendations. Drain and set aside.</p> <p>Cheese Sauce 1. In the same pot the pasta was cooked in, melt the 4 Tbsp butter over medium heat. Add the flour and stir to combine with the butter. 2. Stir the ground mustard and paprika into the butter-flour mixture. Cook this mixture for 2 minutes, stirring frequently. 3. Whisk in the half and half slowly to avoid lumps. 4. Bring the half and half and butter-flour mixture to a simmer, stirring occasionally all the way to the bottom of the pot. 5. Lower the heat and stir frequently for five minutes until the sauce has thickened. 6. Add the processed cheese and stir to melt it into the sauce. 7. Off the heat, add the cheddar and gouda cheeses, a little bit at a time, until all the cheeses are melted into the sauce. 8. Stir in the Sriracha sauce. 9. Add the drained pasta and stir to combine with the cheese sauce. 10. Transfer the pasta and cheese sauce mixture to a casserole dish. 11. Top evenly with the bread crumb mixture. 12. After preheating, place the baking dish in the oven.</p>

Casserole			
Menu	Amount	Food Temp.	Instructions
	Cookware	Rack Position	
Gratin Potatoes	1 casserole (Serves 6-8)	Room	<p>Ingredients</p> <p>1 Tbsp unsalted butter, room temperature 1 garlic clove, smashed 2 ½ pounds Yukon Gold potatoes or 4-5 russet potatoes, washed 2 ½ cups heavy cream 4 oz Gruyere or Parmesan cheese, grated kosher salt and ground black pepper to taste</p> <p>Instructions</p> <p>Serves 6-8</p> <ol style="list-style-type: none"> 1. Generously butter the casserole dish. 2. Rub the smashed garlic clove all over the buttered casserole dish. 3. Cut the potatoes into 1/8 inch thick slices using a knife or a mandolin. 4. Build the dauphinoise by placing a portion of the heavy cream onto the bottom of the casserole dish. 5. Follow this with some of the sliced potatoes, the cheese, and salt and pepper. 6. Add more of the heavy cream and repeat with the potatoes, cheese, and salt and pepper. 7. Continue to build and layer the potatoes to fill the casserole dish. 8. Cover the top layer of potatoes with parchment paper. Press down on the paper so it touches the potatoes. 9. After preheating, place the covered baking dish directly on the rack. 10. When the oven beeps, remove the parchment paper.
	13 x 9 inch Baking dish	3	

Pizza			
Menu	Amount	Food Temp.	Instructions
	Cookware	Rack Position	
Frozen Thin Crust	1 pizza (about 18.5 oz)	Frozen	<ol style="list-style-type: none"> 1. Remove the pizza from the packaging. 2. After preheating, place the pizza directly on the rack.
	Directly On Rack	4	
Frozen Rising Crust	1 pizza (about 29 oz)	Frozen	<ol style="list-style-type: none"> 1. Remove the pizza from the packaging. 2. After preheating, place the pizza directly on the rack.
	Directly On Rack	4	

Pizza			
Menu	Amount	Food Temp.	Instructions
	Cookware	Rack Position	
Homemade Pizza	14-inch pizza (serves 6-8)	Room	<p>Ingredients</p> <p>Dough 8 oz all-purpose flour, ½ Tbsp kosher salt, ½ cup warm water, about 115°F, 1/8 tsp sugar, ½ Tbsp active dry yeast 1 Tbsp olive oil + more for brushing</p> <p>Homemade Sauce 1 28-oz can of whole peeled tomatoes (preferably San Marzano) 1 6-oz can of tomato paste, 1 Tbsp fresh basil, roughly chopped 2 Tbsp olive oil, or olive oil blend, 1 Tbsp kosher salt 1/2 tsp black pepper, 1 Tbsp granulated garlic, 1 Tbsp sugar * Store bought sauce can be used instead for simplicity.</p> <p>Pizza ½ to ¾ cup sauce, 8 oz shredded mozzarella cheese</p> <p>Instructions Serves 6-8 (Makes one 14" pizza)</p> <p>Dough</p> <ol style="list-style-type: none"> In the bowl of an electric stand mixer, whisk together the flour and salt. In a separate bowl, add the water, sugar, yeast, and olive oil. Whisk together the yeast mixture. Set it aside until it foams and bubbles, about 3-5 minutes. Place the mixer bowl onto the mixer stand and attach the dough hook. Add the yeast mixture to the flour and begin mixing the dough on medium speed for 8 1/2 minutes. If the dough is not completely combined, mix for another minute. If the dough is sticking to the bowl, add another 1/4 cup of flour and mix for another minute. If the dough is too dry, add another 1/4 cup of water and mix for another minute. Pick the dough up and begin to form a ball by gently folding the dough under itself. Place onto a lightly oiled sheet pan. Brush the dough ball with olive oil to keep it moist. Cover with plastic wrap and allow dough to rise until doubled in size, about an hour or so. Turn the dough ball onto a lightly floured surface. Begin shaping the dough ball by pressing down with your fingertips into the dough to form a 6-inch-round circle. Use a small amount of flour as needed to prevent sticking. <p>Sauce</p> <ol style="list-style-type: none"> Open the cans of tomatoes and empty them into a blender. Roughly chop the basil. Add the tomato paste, chopped basil, and spices to the blender. Blend the ingredients until the sauce is well blended, about 30 seconds. <p>Pizza</p> <ol style="list-style-type: none"> To stretch the dough, place the dough onto a lightly floured surface and gently press into a circle, flipping several times and adding a pinch of flour if the dough is sticky. Once you have a 6- or 8-inch circle, begin rolling with the rolling pin to gently stretch the dough, turning it slightly to keep the circle shape. Place your pizza dough onto a lightly floured pizza peel or nonstick pizza pan. You can cut the dough with a pizza cutter to form a circle or to make it smaller. Use the dough docker to make indents in the dough. These holes prevent bubbles in your pizza crust. Evenly spread the sauce over the entire surface of the dough, leaving a 1-inch gap around the outer edge of the dough. Place the cheese on top of the sauce. Leave about a half-inch border from the sauce edge. The cheese is going to spread and will stay on top of your pizza this way. After preheating, place the pizza pan on the rack or use the peel to transfer the pizza to a pizza stone. After cooking, cool for 5 minutes before slicing.
	On Pizza Pan	4	

Pastry			
Menu	Amount	Food Temp.	Instructions
	Cookware	Rack Position	
Refrigerated Croissants	2~8 EA	Refrigerated	Prepare the croissants. Roll the croissant triangles into croissant shapes. Place the croissants on the ungreased half sheet pan. After preheating, place the half sheet pan with the croissants back in the oven.
	1/2 Sheet Pan	3	
Frozen Dinner Rolls	1~6 EA	Frozen	Place the frozen dinner rolls on the half sheet pan. After preheating, place the half sheet pan with the frozen dinner rolls back in the oven.
	1/2 Sheet Pan	3	
Refrigerated Cinnamon Rolls	1 can (8 rolls)	Refrigerated	Prepare the Cinnamon Rolls. Place the rolls with cinnamon side up on an ungreased cake pan. After preheating, place the cake pan with the cinnamon rolls back in the oven.
	9 inch round cake pan	3	

Vegetables			
Menu	Amount	Food Temp.	Instructions
	Cookware	Rack Position	
Baby Carrots	15-30 oz	Refrigerated	Ingredients Kosher salt, ground black pepper, oil to taste Instructions 1. Wash and peel (if necessary) the baby carrots. 2. Brush or lightly spray with oil. 3. Add salt and pepper to taste. 4. Place the baby carrots on the half sheet pan
	1/2 Sheet Pan	3	
Carrots, Diced	15-30 oz	Refrigerated	Ingredients Kosher salt, ground black pepper, oil to taste Instructions 1. Peel and cut carrots into 1/2~3/4 in. cubes. 2. Brush or lightly spray with oil. 3. Add salt and pepper to taste. 4. Place the carrots on the half sheet pan.
	1/2 Sheet Pan	3	
White Mushrooms	5-20 oz	Refrigerated	Ingredients Kosher salt, ground black pepper, oil to taste Instructions 1. If desired, cut mushrooms into halves. 2. Brush or lightly spray with oil. 3. Add salt and pepper to taste. 4. Place the mushrooms on the half sheet pan.
	1/2 Sheet Pan	3	
Asparagus	5-20 oz	Refrigerated	Ingredients Kosher salt, ground black pepper, oil to taste Instructions 1. Trim the heartier, woody ends of the asparagus and discard. 2. Brush or lightly spray with oil. 3. Add salt and pepper to taste. 4. Place the asparagus on the half sheet pan.
	1/2 Sheet Pan	3	

Vegetables			
Menu	Amount	Food Temp.	Instructions
	Cookware	Rack Position	
Broccoli	15-30 oz	Refrigerated	Ingredients Kosher salt, ground black pepper, oil to taste Instructions 1. Cut the broccoli into bite-size florets. 2. Brush or lightly spray with oil. 3. Add salt and pepper to taste. 4. Place the broccoli on the half sheet pan.
	1/2 Sheet Pan	3	
Cauliflower	15-30 oz	Refrigerated	Ingredients Kosher salt, ground black pepper, oil to taste Instructions 1. Cut the cauliflower into bite-size florets. 2. Brush or lightly spray with oil. 3. Add salt and pepper to taste. 4. Place the cauliflower on the half sheet pan.
	1/2 Sheet Pan	3	
Brussels Sprouts	15-30 oz	Refrigerated	Ingredients Kosher salt, ground black pepper, oil to taste Instructions 1. Cut brussels sprouts in half, or in quarters if they are large. 2. Brush or lightly spray with oil. 3. Add salt and pepper to taste. 4. Place the brussels sprouts on the half sheet pan..
	1/2 Sheet Pan	3	
Beets, Diced	15-30 oz	Refrigerated	Ingredients Kosher salt, ground black pepper, oil to taste Instructions 1. Peel and cut beets into 1/2~3/4 in. cubes 2. Brush or lightly spray with oil. 3. Add salt and pepper to taste. 4. Place the diced beets on the half sheet pan.
	1/2 Sheet Pan	3	
Sweet Potatoes, Diced	15-30 oz	Room	Ingredients Kosher salt, ground black pepper, oil to taste Instructions 1. Peel and cut sweet potatoes into 1/2~3/4 in. cubes. 2. Brush or lightly spray with oil. 3. Add salt and pepper to taste. 4. Place the diced sweet potatoes on the half sheet pan.
	1/2 Sheet Pan	3	
Sweet Potato, Whole	1-4 EA (8 oz each)	Room	1. Wash and prick the skin all over the sweet potatoes. 2. Place the sweet potatoes directly on the rack.
	Directly On Rack	3	
Cherry Tomatoes	15-30 oz	Refrigerated	Ingredients Kosher salt, ground black pepper, oil to taste Instructions 1. Wash the cherry tomatoes. 2. Remove stems, if present 3. Brush or lightly spray with oil. 4. Add salt and pepper to taste. 5. Place the cherry tomatoes on the half sheet pan.
	1/2 Sheet Pan	3	

Vegetables			
Menu	Amount	Food Temp.	Instructions
	Cookware	Rack Position	
Corn on the Cob	1 sheet (8-12 oz each)	Refrigerated	<p>Ingredients Kosher salt, ground black pepper, to taste, 1/2 Tbsp. of oil per (1/2) piece</p> <p>Instructions 1. Remove husks and silk from corn cobs and cut cobs in half. 2. Brush or lightly spray with oil. 3. Add salt and pepper to taste. 4. Place the corn on a half sheet pan 5. When the oven beeps, turn the food over.</p>
	1/2 Sheet Pan	3	
Green Beans	10-20 oz	Refrigerated	<p>Ingredients Kosher salt, ground black pepper, oil to taste</p> <p>Instructions 1. Wash the green beans. 2. Brush or lightly spray with oil. 3. Add salt and pepper to taste. 4. Place the green beans on a half sheet pan.</p>
	1/2 Sheet Pan	3	

Potatoes			
Menu	Amount	Food Temp.	Instructions
	Cookware	Rack Position	
Home Fries	15-30 oz	Room	<p>Ingredients For 15 oz of Yukon Gold potatoes 2 Tbsp olive oil 1 tsp kosher salt 1/2 tsp ground black pepper 1 tsp smoked paprika 1/2 tsp garlic powder 2 Tbsp chopped parsley, for garnish</p> <p>Instructions 1. Dice potatoes into 1" cubes and place on half sheet pan. 2. Season the potatoes with salt, spices, and olive oil. Mix thoroughly. 3. Roast for 20 min depending on the size, stirring halfway through the cooking process. 4. Garnish with fresh herbs for color and serve immediately.</p>
	1/2 Sheet Pan	3	
Potato Wedges	15-30 oz	Room	<p>Ingredients Kosher salt, ground black pepper, oil to taste</p> <p>Instructions 1. Wash and cut the potatoes into wedges. 2. Brush or lightly spray with oil. 3. Add salt and pepper to taste. 4. Place the potatoes on a half sheet pan.</p>
	1/2 Sheet Pan	3	
Smashed Potatoes	15-30 oz	Room	<p>Ingredients Kosher salt, ground black pepper, oil to taste</p> <p>Instructions 1. Cook russet potatoes in boiling water for 15 minutes and then strain and chill. 2. Combine all spices in a small mixing bowl. 3. Smash the potatoes using the side of a knife to flatten. 4. Place smashed potatoes on a half sheet pan. 5. Add olive oil and seasoning.</p>
	1/2 Sheet Pan	3	

Dessert			
Menu	Amount	Food Temp.	Instructions
	Cookware	Rack Position	
Apple Pie	9" pie (serves 6)	Room	<p>Ingredients</p> <p>Pie Crust 2 ½ cups pastry flour, 1 tsp salt, 1 tsp sugar 2 sticks unsalted butter, cut into small pieces and well chilled 4-6 Tbsp ice water, as needed</p> <p>Apples 8 tart apples, like Granny Smith 2 Tbsp lemon juice, ¼ cup sugar, ½ tsp ground cinnamon ½ tsp kosher salt, 1 Tbsp unsalted butter, cut into small pieces</p> <p>Instructions Makes one 9" pie Serves 6 Pie Crust 1. Use a food processor with a blade attachment to combine the pastry flour, salt and sugar. 2. Add the chilled butter pieces and pulse until it resembles coarse meal. 3. Add ice cold water a tablespoon at a time and mix until the dough just comes together. 4. Turn the dough onto a lightly floured counter and bring the dough together. 5. Divide the dough into 2 equal portions and flatten each into a disk. Wrap each in plastic wrap and refrigerate for an hour.</p> <p>Apples 1. Peel, core, quarter and thinly slice the apples and place them in a large bowl. 2. Toss the apples with the lemon juice, followed by the sugar, cinnamon, and kosher salt.</p> <p>To Assemble the Pie 1. On a well floured counter, roll each pie dough out to 12 inches in diameter. Use one rolled out pie dough to line a deep pie pan. 2. Add the apples to the pie pan and dot with 1 Tbsp butter. 3. Use the other pie dough to cover the filling. Tuck the top crust under the bottom crust all around. Pinch together to close. 4. Cut a few slits in the top crust to allow steam to escape. In a small bowl, combine 1 egg and 1 Tbsp milk. Brush the egg wash over the top crust. 5. After preheating, place the pie pan directly on the rack and a foil-lined catch pan on the rack below. 6. Cool on a rack for 1 hour before serving.</p>
	Pie pan directly on rack and catch pan on rack below	3	
Brownies	1 Pan (serves 6)	Room	<p>Ingredients</p> <p>½ stick unsalted butter, 6 oz semisweet chocolate, chopped ½ cup dark brown sugar, 1 cup sugar, 3 large eggs ¼ cup cocoa powder, ½ tsp kosher salt ½ cup + 2 Tbsp all-purpose flour</p> <p>Instructions Serves 6 1. Line an 8"x8" baking pan with parchment paper. 2. In a microwave-safe bowl, combine the butter and chocolate. 3. Microwave in short intervals and stir after each interval until melted and smooth. 4. Add the sugars and whisk until combined. 5. Add the eggs one at a time, mixing until incorporated. 6. Sift the cocoa powder, salt and flour into the bowl and mix until combined. 7. Pour the batter into the 8"x8" baking pan. 8. After the oven preheats, place the pan back in the oven. 9. After cooking, let the brownies cool for 15 minutes in the pan before slicing.</p>
	8x8 inch pan	3	

Dessert			
Menu	Amount	Food Temp.	Instructions
	Cookware	Rack Position	
Scones	1 sheet of 24 scones	Room	<p>Ingredients 2 ¼ cups pastry flour, 2 tsp sugar, 2 Tbsp + 1 tsp baking powder 4 ½ tsp kosher salt, 3 sticks unsalted butter, chilled and cut into small pieces 6 cups all-purpose flour, 3 cups buttermilk</p> <p>Instructions Makes 24 scones 1. Use a food processor with the blade attachment to combine the pastry flour, sugar, baking powder and salt. 2. Add the chilled butter pieces and pulse until the mixture resembles coarse meal. 3. In a large bowl, combine the all-purpose flour with the mixture from the food processor. 4. Add the buttermilk and mix until the dough comes together. 5. Turn the dough onto a floured surface and roll out to 1½ in. thick. 6. Cut the dough into the desired shape or use a round biscuit cutter. 7. Transfer the cut scones to a parchment lined half sheet pan. 8. After the oven preheats, place the scones back in the oven to cook.</p>
	1/2 Sheet Pan	3	
Sponge Cake	2 cakes	Room	<p>Ingredients 1 cup cake flour, 6 large eggs, separated 1 cup sugar, ¾ cup sugar for egg yolks, ¼ cup sugar for egg whites 2 tsp vanilla, ¼ tsp salt</p> <p>Instructions 1. Grease the bottom and sides of two 9" cake pans with unsalted butter. Line the bottoms of the cake pans with parchment paper and butter the paper. Dust the pans with all-purpose flour. 2. Use an electric mixer with a whisk attachment to combine the egg yolks with ¾ cup sugar. Beat on medium high for 5 minutes until the egg yolk mixture is thick and pale in color. 3. In a clean bowl, use an electric mixer with a whisk attachment to beat the egg whites until soft peaks form. Slowly add ¼ cup sugar and continue beating until stiff, glossy peaks form. 4. Fold 1/3 of the yolk mixture at a time into the whipped whites. 5. Sift the cake flour over the egg mixture and gently fold it in. 6. Divide the batter equally between the pans. 7. After preheating the oven, place the pans in the oven and bake. 8. Let the cakes cool for 5 minutes before inverting onto a cooling rack.</p>
	9 in. cake pans	3	

70 OPERATION

Dessert			
Menu	Amount	Food Temp.	Instructions
	Cookware	Rack Position	
Cheesecake	1 cake (serves 6-8)	Room	<p>Ingredients</p> <p>Cookie Crust 1 stick unsalted butter, room temperature 2 Tbsp granulated sugar, 1 cup brown sugar, 1 egg 1 cup all-purpose flour, ¼ tsp baking soda 1/8 tsp baking powder, ¼ tsp salt</p> <p>Cheesecake Batter 2 lb. cream cheese, room temperature, 1 ½ cups granulated sugar 2 eggs, 2 egg yolks, 5 Tbsp heavy cream, ½ tsp vanilla extract</p> <p>Instructions Serves 6-8 Cookie Crust 1. Preheat the oven to 350°F in the Bake mode. 2. Pan spray and line the 9" springform cake pan with parchment paper. 3. Place the butter in the bowl of a stand mixer and begin to soften it with the paddle attachment. 4. Add the sugar and brown sugar and cream them with the butter until well blended, 3 to 5 minutes. 5. Add the egg to the mixture and combine. 6. Add the flour, baking soda, baking powder and salt to the mixer bowl and mix gently until just combined. 7. Remove the bowl from the mixer and empty it into the prepared pan. Gently press the cookie dough down to line the entire bottom of the springform pan. 8. Place the pan in the oven and bake for 20 minutes. 9. Allow the cookie to cool while preparing the cheesecake batter.</p>
	9" springform pan in water bath	3	<p>Cheesecake Batter 1. Place the cream cheese in the bowl of a stand mixer and mix to soften it. 2. Add the sugar and mix until well combined, about 5 minutes. 3. Add the eggs and egg yolks slowly to insure they are well combined. 4. Add the heavy cream and vanilla extract and mix until just combined. 5. Pour the batter on top of the cooled cookie crust in the springform pan. 6. Wrap the bottom of the springform pan with foil, carrying it up the sides. 7. Place the foil-wrapped springform pan into a larger casserole dish. 8. Add just enough water to the casserole dish to reach up the sides of the pan but not above the foil. 9. After preheating, place the casserole dish with the cheesecake in the oven and bake. 10. Allow the cake to cool in the water bath for 1 hour. After an hour, remove it from the water bath and place it in the refrigerator overnight in the springform pan.</p>

Dessert			
Menu	Amount	Food Temp.	Instructions
	Cookware	Rack Position	
Chocolate Chip Cookies	36 cookies (12 to a sheet)	Room	<p>Ingredients (Makes 3 dozen cookies) 2 ½ sticks salted butter, 1 ¼ cups brown sugar, 1 cup + 2 Tbsp sugar 2 large eggs, 1 tsp vanilla extract, 3 2/3 cups all-purpose flour 1 ¼ tsp baking powder, 1 ¼ tsp baking soda 1 ¼ tsp fine sea salt, 20 oz chocolate chips</p> <p>Instructions Cooked 12 to a sheet pan. 1. Cream the butter with the sugars in an electric mixer until light, about 5 minutes. Scrape down the bowl and paddle as needed. 2. Add the eggs one at a time, mixing well after each addition. 3. Scrape down the bowl and paddle and add the vanilla. 4. Sift the flour, powder, baking soda and salt together. 5. Add the dry mixture to the mixture in the wet mixture. 6. Scrape down the bowl and paddle. 7. Fold in the chocolate chips. 8. Line half sheet pans with parchment paper. 9. Scoop the cookie dough onto the pans in a 3x4 pattern. 10. After preheating, place the half sheet pan in the oven. Bake the cookies one half sheet pan at a time.</p>
	1/2 Sheet Pan	3	
Baguette	2 demi baguettes	Room	<p>Ingredients 0.25 oz package active dry yeast, about ¾ Tbsp of yeast 11 oz water, about 100°F 18 oz bread flour 1 Tbsp of salt</p> <p>Instructions 1. In a small bowl dissolve the yeast in the warm water using a whisk. 2. Add the yeast and water mixture to the bowl of an electric mixer. 3. Add the bread flour and salt to the bowl. 4. Use the dough hook to mix the dough on low speed for 7 minutes. 5. Place the dough into a bowl and let it rise for 30 minutes or until doubled in size. 6. Punch the dough down and let it rise again until doubled in size. 7. Remove the dough and place it on a work surface. 8. Divide the dough into 2 equal pieces. 9. Shape each piece into a small baguette. 10. Place the baguettes onto a parchment lined half sheet pan. 11. Cover the baguettes with plastic wrap and allow to double in size. 12. After the baguettes have doubled in size, use a serrated knife and slash each baguette with 3 four inch long, half inch deep, diagonal slashes. 13. Place the baguettes on the half sheet pan. 14. After preheating, place the half sheet pan back in the oven.</p>
	1/2 Sheet Pan	3	

Dessert			
Menu	Amount	Food Temp.	Instructions
	Cookware	Rack Position	
Fruit Tart	1 tart	Room	<p>Ingredients</p> <p>Tart Dough 2 cups all-purpose flour, 1 ½ Tbsp sugar, 1 Tbsp brown sugar 1 ½ sticks unsalted butter, cold and cut into small pieces 1 whole egg, 1 egg yolk, 2 Tbsp ice water</p> <p>Pastry Cream 2/3 cup sugar, ¼ cup cornstarch pinch of kosher salt, 2 large eggs, 2 cups milk 2 Tbsp unsalted butter, cut into small pieces, 2 tsp vanilla</p> <p>Instructions</p> <p>Tart Dough</p> <ol style="list-style-type: none"> Place the flour and sugars into the work bowl of a food processor and pulse to combine. Add the cold pieces of butter and pulse until the mixture resembles coarse meal. Add the whole egg, egg yolk and the ice water and pulse until the dough just forms a ball. Remove from the work bowl and form into a disc. Wrap the dough in plastic wrap and place it in the refrigerator while the filling is being made.
	Tart pan	3	<p>Pastry Cream</p> <ol style="list-style-type: none"> In a saucepan, combine the sugar and milk. Gently warm it to a lazy simmer. In a bowl, combine the eggs, cornstarch, salt and vanilla. Add the warm milk mixture to the egg mixture in small amounts to temper the eggs and avoid cooking them. Return everything back to the saucepan and cook the custard until it thickens and begins to bubble. Strain through a fine mesh strainer and stir in the butter. Cool the pastry cream to room temperature before using. <p>To Assemble the Tart</p> <ol style="list-style-type: none"> Remove the tart dough from the refrigerator. Place the dough on a lightly floured work surface. Sprinkle a little more flour on the dough and roll the dough out to 1/8" thick. Gently spray the tart pan with pan spray and line the tart pan with the dough. After preheating the oven, place the tart pan back in the oven. After cooking, allow the tart shell to cool completely before adding the pastry cream and decorating with fresh fruit.
Muffins	1 Pan	Room	<p>Ingredients</p> <p>2 cups all-purpose flour, ½ cup sugar, 2 tsp baking powder ½ tsp kosher salt, ¾ cup milk ½ cup unsalted butter, melted and cooled, 2 large eggs</p> <p>Instructions</p> <ol style="list-style-type: none"> Line a muffin pan with paper liners and set aside. In a small bowl, whisk the flour, sugar, baking powder, and salt together. In a medium bowl, whisk the milk, butter, and eggs together until well combined. Add the dry ingredients to the wet ingredients and stir with a silicone spatula just until combined. Divide the batter evenly between the muffin cups. After preheating is done, place the muffin pan in the oven.
	Muffin pan	3	

Toast			
Menu	Amount	Food Temp.	Instructions
	Cookware	Rack Position	
Bagels	1-4 EA	Room	Slice the bagels in half along the narrow edge. Place the bagels with the inner side up on the grid on the broiler pan.
	Grid on broiler pan	5	
Bread Slices	1-4 EA	Room	Place bread slices on the grid on the broiler pan. When the oven beeps, flip the bread over.
	Grid on broiler pan	5	
English Muffins	1-4 EA	Room	Slice the English muffins in half along the narrow edge. Place the English muffins with the inner side up on the grid on the broiler pan.
	Grid on broiler pan	5	

Frozen Products			
Menu	Amount	Food Temp.	Instructions
	Cookware	Rack Position	
Chicken Nuggets	10-40 EA (0.6 oz each)	Frozen	Place frozen chicken nuggets on the LG air fry tray.
	Air Fry Tray	3	
Chicken Tenders	6-24 EA (1 oz each)	Frozen	Place frozen chicken tenders on the LG air fry tray.
	Air Fry Tray	3	
Mozzarella Sticks	6-24 EA (1 oz each)	Frozen	Place frozen mozzarella sticks on the LG air fry tray.
	Air Fry Tray	3	
Mac & Cheese	1 casserole (40 oz)	Frozen	1. Remove casserole from packaging. 2. After preheating, place the half sheet pan with the frozen mac and cheese back in the oven.
	1/2 Sheet Pan	3	
Burritos	1-8 EA (5 oz each)	Frozen	1. Remove burritos from packaging. 2. After preheating, place half sheet pan with burritos back in the oven.
	1/2 Sheet Pan	3	
Biscuits	5-20 EA (2 oz each)	Frozen	Remove the package and place the frozen biscuits on the LG air fry tray.
	Air Fry Tray	3	
Tater Tots	1-4 servings	Frozen	Place the frozen tater tots on the LG air fry tray. 1 serving is about 12 oz.
	Air Fry Tray	3	
French Fries Straight	1-4 servings	Frozen	Place frozen french fries on the LG air fry tray. 1 serving is about 5 oz.
	Air Fry Tray	3	
French Fries Crinkled	1-4 servings	Frozen	Place frozen french fries on the LG air fry tray. 1 serving is about 8 oz.
	Air Fry Tray	3	

74 OPERATION

Frozen Products			
Menu	Amount	Food Temp.	Instructions
	Cookware	Rack Position	
Hashbrowns Patties	4-16 EA (2.3 oz each)	Frozen	Place frozen hash browns on the LG air fry tray.
	Air Fry Tray	3	
Sweet Potato Fries	1-4 servings	Frozen	Place frozen sweet potato fries on the LG air fry tray. 1 serving is about 6 oz.
	Air Fry Tray	3	
Onion Rings	1-4 servings	Frozen	Place frozen onion rings on the LG air fry tray. 1 serving is about 5 oz.
	Air Fry Tray	3	
Breaded Fish Fillet	4-16 EA (2 oz each)	Frozen	Place frozen breaded fish fillets on the LG air fry tray.
	Air Fry Tray	3	
Breakfast Sausage	6-24 EA (1 oz each)	Frozen	Place frozen breakfast sausages on the LG air fry tray.
	Air Fry Tray	3	
Corn Dogs	2-8 EA (2.75 oz each)	Frozen	1. Remove corn dogs from packaging. 2. After preheating, place half sheet pan with corn dogs back in the oven.
	1/2 Sheet Pan	3	
Egg Rolls	2-4 EA (2.7 oz each)	Frozen	1. Remove egg rolls from packaging. 2. After preheating, place half sheet pan with egg rolls back in the oven. 3. When the oven beeps, flip the egg rolls over.
	1/2 Sheet Pan	3	
Meatballs	6-24 EA (0.5 oz each)	Frozen	1. Remove meatballs from packaging. 2. After preheating, place half sheet pan with meatballs back in the oven. 3. When the oven beeps, flip the meatballs over.
	1/2 Sheet Pan	3	
Pretzels	2-6 EA (2.2 oz each)	Frozen	1. Remove pretzels from packaging. 2. After preheating, place half sheet pan with pretzels back in the oven.
	1/2 Sheet Pan	3	

SMART FUNCTIONS

LG ThinQ Application

This feature is only available on models with Wi-Fi.

The **LG ThinQ** application allows you to communicate with the appliance using a smartphone.

LG ThinQ Application Features

- **Smart Diagnosis™**
 - This function provides useful information for diagnosing and solving issues with the appliance based on the pattern of use.
- **Settings**
 - Change oven settings, including convection auto conversion and thermostat adjustment.
- **Scan to Cook**
 - Scan the barcode on a ready-made meal using the LG ThinQ application and send the recommended or customized cooking instructions straight to your oven. Remote Start must be activated on the oven to use Scan to Cook.
- **Remote Start**
 - Remotely start the preheat mode or turn off the oven.
- **Monitoring**
 - This function helps you check the current status, remaining time, cook settings and end time in one place.
- **Product Notifications**
 - Turn on the Push Alerts to receive appliance status notifications. The notifications are triggered even if the **LG ThinQ** application is not open.
- **Timer**
 - You can set the timer from the application.
- **Firmware Update**
 - Keep the appliance updated.

NOTE

- If you change your wireless router, Internet service provider, or password, delete the registered appliance from the **LG ThinQ** application and register it again.
- This information is current at the time of publication. The application is subject to change for product improvement purposes without notice to users.

Installing LG ThinQ Application and Connecting an LG Appliance

Models with QR Code

Scan the QR code attached to the product using the camera or a QR code reader application on your smartphone.



Models without QR Code

- 1 Search for and install the **LG ThinQ** application from the Google Play Store or Apple App Store on a smartphone.
- 2 Run the **LG ThinQ** application and sign in with your existing account or create an LG account to sign in.
- 3 Touch the add (+) button on the **LG ThinQ** application to connect your LG appliance. Follow the instructions in the application to complete the process.

NOTE

- To verify the Wi-Fi connection, check that the Wi-Fi indicator on the control panel is lit.
- The appliance supports 2.4 GHz Wi-Fi networks only. To check your network frequency, contact your Internet service provider or refer to your wireless router manual.
- **LG ThinQ** is not responsible for any network connection problems or any faults, malfunctions, or errors caused by network connection.
- The surrounding wireless environment can make the wireless network service run slowly.
- If the distance between the appliance and the wireless router is too far, the signal becomes weak. It may take a long time to connect or fail to install the application.
- If the appliance is having trouble connecting to the Wi-Fi network, it may be too far from the router. Purchase a Wi-Fi repeater (range extender) to improve the Wi-Fi signal strength.
- The network connection may not work properly depending on the Internet service provider.
- The Wi-Fi may not connect or the connection may be interrupted because of the home network environment.

NOTE

- If the appliance cannot be connected due to problems with the wireless signal transmission, unplug the appliance and wait about a minute before trying again.
- If the firewall on your wireless router is enabled, disable the firewall or add an exception to it.
- The wireless network name (SSID) should be a combination of English letters and numbers. (Do not use special characters.)
- Smartphone user interface (UI) may vary depending on the mobile operating system (OS) and the manufacturer.
- If the security protocol of the router is set to **WEP**, network setup may fail. Change the security protocol (**WPA2** is recommended), and connect the product again.

Smart Diagnosis™ Feature

Use this feature to help you diagnose and solve problems with your appliance.

NOTE

- For reasons not attributable to LGE's negligence, the service may not operate due to external factors such as, but not limited to, Wi-Fi unavailability, Wi-Fi disconnection, local app store policy, or app unavailability.
- The feature may be subject to change without prior notice and may have a different form depending on where you are located.

Using LG ThinQ to Diagnose Issues

If you experience a problem with your Wi-Fi equipped appliance, it can transmit troubleshooting data to a smartphone using the **LG ThinQ** application.

- Launch the **LG ThinQ** application and select the **Smart Diagnosis** feature in the menu. Follow the instructions provided in the **LG ThinQ** application.

Using Audible Diagnosis to Diagnose Issues

Follow the instructions below to use the audible diagnosis method.

- Launch the **LG ThinQ** application and select the **Smart Diagnosis** feature in the menu. Follow the instructions for audible diagnosis provided in the **LG ThinQ** application.
- 1** Open the **LG ThinQ** application on the smart phone.
 - 2** In the application, select the appliance from your list of connected appliances and then press the dots at the upper right of the screen.
 - 3** Select **Smart Diagnosis**, then press the **Start Smart Diagnosis** button.

NOTE

- If the diagnosis fails several times, use the following instructions.

- 4 Select the **Audible Diagnosis**.
- 5 Follow the instructions on the smart phone.
- 6 Keep the phone in place until the tone transmission has finished. View the diagnosis on the phone.

NOTE

- For best results, do not move the phone while the tones are being transmitted.

Open Source Software Notice Information

To obtain the source code that is contained in this product, under GPL, LGPL, MPL, and other open source licenses that have the obligation to disclose source code, and to access all referred license terms, copyright notices and other relevant documents, please visit <https://opensource.lge.com>.

LG Electronics will also provide open source code to you on CD-ROM for a charge covering the cost of performing such distribution (such as the cost of media, shipping, and handling) upon email request to opensource@lge.com. This offer is valid to anyone in receipt of this information for a period of three years after our last shipment of this product.

Radio Equipment Specifications

Type	Operating Frequency Range	Output Power (Max.)
Wireless LAN	2 400 MHz - 2 472 MHz	< 1 W
Bluetooth [†]	2 400 MHz - 2 483.5 MHz	

† This feature is only available on some models.

FCC Notice

The following notice covers the transmitter module contained in this product.

This equipment has been tested and found to comply with the limits for a Class B digital device, pursuant to Part 15 of the FCC Rules. These limits are designed to provide reasonable protection against harmful interference in a residential installation. This equipment generates, uses, and can radiate radio frequency energy and, if not installed and used in accordance with the instructions, may cause harmful interference to radio communications. However, there is no guarantee that interference will not occur in a particular installation. If this equipment does cause harmful interference to radio or television reception, which can be determined by turning the equipment off and on, the user is encouraged to try to correct the interference by one or more of the following measures:

- Reorient or relocate the receiving antenna.
- Increase the separation between the equipment and the receiver.
- Connect the equipment into an outlet on a circuit different from that to which the receiver is connected.
- Consult the dealer or an experienced radio/TV technician for help.

This device complies with Part 15 of the FCC Rules. Operation is subject to the following two conditions:

- 1) This device may not cause harmful interference and
- 2) This device must accept any interference received, including interference that may cause undesired operation.

Any changes or modifications in construction of this device which are not expressly approved by the party responsible for compliance could void the user's authority to operate the equipment.

FCC RF Radiation Exposure Statement

This equipment complies with FCC radiation exposure limits set forth for an uncontrolled environment. This transmitter must not be co-located or operating in conjunction with any other antenna or transmitter.

This equipment should be installed and operated with a minimum distance of 20 cm (7.8 inches) between the antenna and your body. Users must follow the specific operating instructions for satisfying RF exposure compliance.

MAINTENANCE

NOTE

- Depending on the model, your range may contain different cooktop modules requiring different maintenance procedures. Take care when cleaning the range to apply cleaners only as recommended.

CAUTION

- Do not clean this appliance with bleach.
- To prevent burns, wait until the cooktop has cooled down before touching any of its parts.
- Always wear gloves when cleaning the cooktop.

Control Panel

Clean up splatters with a damp cloth using a glass cleaner. Remove heavier soil with warm, soapy water. Do not use abrasives of any kind.

Gas Surface Burners

Removing and Replacing the Gas Surface Burners

Grates and burner heads/caps can be removed for care and cleaning.

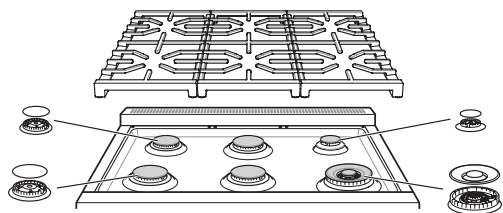

	General burner
Burner cap is properly set.	
Burner cap is NOT properly set.	

Cleaning Burner Heads/Caps

For even and unhampered flame, the slits in the burner heads must be kept clean at all times. The burner heads and caps can be lifted off.

- Wash the burner caps in hot soapy water and rinse with clean water. Run water through the burner from the bottom stem to flush out debris.
- Use care when cleaning the cooktop. The pointed metal ends on the electrodes could cause injury. Hitting an electrode with a hard object may damage it.
- To remove burnt-on food, soak the burner heads in a solution of mild liquid detergent and hot water for 20–30 minutes. For stubborn stains, use a toothbrush.
- The burners will not operate properly if the burner ports or electrodes are clogged or dirty.
- Burner caps and heads should be cleaned routinely, especially after excessive spillover.
- Burners will not light if the cap is removed.

CAUTION

- Do not hit the electrodes with anything hard. Doing so could damage them.
- Do not use steel wool or scouring powders to clean the burners.
- Do not scratch or gouge the port features of the brass burner bases.
- It is normal for brass burners to become tarnished with use.

NOTE

- To clean the brass burners, use mild abrasive cleaners or liquid cleaners.
- To clean port openings, use a stiff, nylon bristle tooth brush.
- Do not use steel wool or steel bristle brushes as they can scratch the brass burner surface.

After Cleaning the Burner Heads/Caps

Shake out any excess water and then let them dry thoroughly. Placing the burner heads upside down will allow the water to drain out more easily. Replace the burner heads and caps over the electrodes on the cooktop in the correct locations according to their size. Make sure the hole in the burner head is positioned over the electrode.

Burner Grates

The range consists of three separate professionalstyle grates. For maximum stability, these grates should only be used when in their proper position.

The center grate can be rotated from front to back.

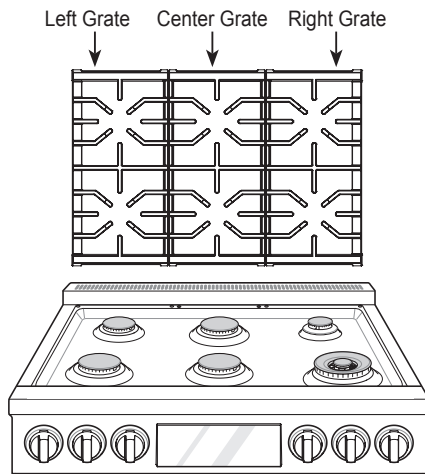

NOTE

Do not operate a burner for an extended period of time without cookware on the grate. The finish on the grate may chip without cookware to absorb the heat.

Gas Cooktop Surface

CAUTION

- To avoid burns, do not clean the cooktop surface until it has cooled.
- Do not lift the cooktop surface. Lifting the cooktop surface can lead to damage and improper operation of the range.
- When water is spilled on the cooktop, wipe up water immediately. If water is left on the cooktop for a long time, discoloration may occur.

Foods with high acid or sugar content may cause a dull spot if allowed to set. Wash and rinse soon after the surface has cooled. For other spills such as oil/grease spattering, etc., wash with soap and water when the surface has cooled, then rinse and polish with a dry cloth.

Cleaning the Burner Grates

CAUTION

- Do not lift the grates out until they have cooled.
- Do not put the grate in the oven during self cleaning mode.
- Grates should be washed regularly and after spillovers.
- Wash the grates in hot, soapy water and rinse with clean water.
- After cleaning the grates, let them dry completely and securely position them over the burners.

Exterior

Painted and Decorative Trim

For general cleaning, use a cloth with hot soapy water. For more difficult soils and built-up grease, apply a liquid detergent directly onto the soil. Leave it on for 30 to 60 minutes. Rinse with a damp cloth and dry. Do not use abrasive cleaners.

Stainless Steel Surfaces

To avoid scratches, do not use steel wool pads.

- 1 Place a small amount of stainless steel appliance cleaner or polish on a damp cloth or paper towel.
- 2 Clean a small area, rubbing with the grain of the stainless steel if applicable.
- 3 Wipe with a clean, dry paper towel or soft cloth.
- 4 Repeat as necessary.

NOTE

- Use warm soapy water or a stainless steel cleaner or polish.
- Always wipe in the direction of the metal surface finish.
- Stainless steel appliance cleaner or polish can be purchased online or from most retailers of appliances or home goods.

Broiler Pan and Grid

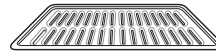

Grid

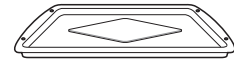

Broiler pan

- Do not store the soiled broiler pan and grid in the range.
- Do not use the self-clean mode to clean the broiler pan and grid.
- Remove the grid from the broiler pan to clean. Carefully pour grease from the pan into an appropriate container.
- Use a plastic scouring pad to clean the broiler pan and grid in hot, soapy water.
- To remove burned on food, cover the grid while it's hot with a wet, soapy dishcloth or paper towels, and allow the residue to soften.
- The broiler pan and grid are dishwasher safe.

Oven Racks

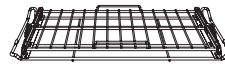

Gliding rack



Rack

Remove the oven racks before operating the self clean cycle.

- 1 Food spilled into the tracks could cause the racks to become stuck. Clean racks with a mild, abrasive cleaner.
- 2 Rinse with clean water and dry.

NOTE

If the racks are cleaned using the self clean cycle (not recommended), the color will turn slightly blue and the finish will become dull. After the self clean cycle is complete, and the oven has cooled, rub the sides of the racks with wax paper or a cloth containing a small amount of vegetable oil. This will make the racks glide more easily into the rack tracks.

Oven Door

- Use soapy water to thoroughly clean the oven door. Rinse well. Do not immerse the door in water.
- You may use a glass cleaner on the outside glass of the oven door. Do not spray water or glass cleaner on the door vents.
- Do not use oven cleaners, cleaning powders, or harsh abrasive cleaning materials on the oven door.
- Do not clean the oven door gasket. The oven door gasket is made of a woven material that is essential for a good seal. Care should be taken not to rub, damage, or remove this gasket.

CAUTION

Do not use harsh cleaners or harsh abrasive cleaning materials on the oven door. Doing so can cause damage.

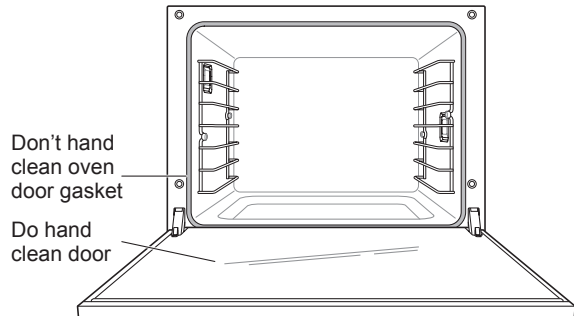

Oven Light

- The oven light will automatically turn on when the door is opened.
- The light becomes hot when it is turned on. To avoid the risk of burns, always turn off the light before cleaning the oven.
- Press the oven light icon  located at the bottom left of the LCD screen to turn off the light. Then clean the light carefully.

Front Manifold Panel and Knobs

It is best to clean the manifold panel after each use of the range. To clean, use a damp cloth and mild soapy water or a 50/50 solution of vinegar and water. Rinse with clean water and polish dry with a soft cloth.

The control knobs may be removed for easy cleaning.

- 1 To remove the knobs for cleaning the knobs, make sure that they are in the **OFF** position and pull them straight off the stems.
- 2 To replace the knobs, make sure the knob has the **OFF** position centered at the top, and slide the knob directly onto the stem.

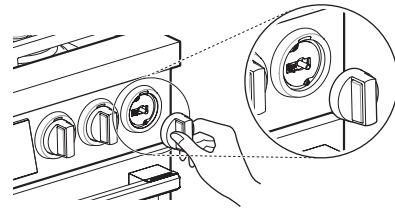

CAUTION

- To avoid damaging the finish on the knobs and manifold panel, do not use abrasive cleansers, strong liquid cleaners, plastic scouring pads or oven cleaners.
- Do not try to bend the knobs by pulling them up or down, and do not hang a towel or other objects on them. This can damage the gas valve shaft.
- Do not try to remove the LED rings behind the control knobs.

NOTE

To prevent scratching, do not use abrasive cleaners on any of these materials.

Remove debris which collects in the crevices with a folded cloth or table knife.

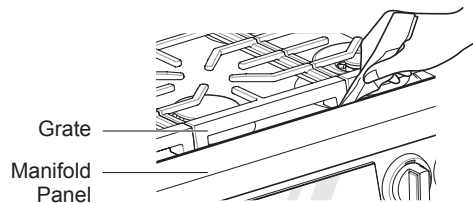

NOTE

Take care not to scratch the surface.

EasyClean®

LG's EasyClean® enamel technology provides two cleaning options for the inside of the range. The EasyClean® feature takes advantage of LG's new enamel to help lift soils without harsh chemicals, and it runs using ONLY WATER for just 10 minutes in low temperatures to help loosen LIGHT soils before hand-cleaning.

While EasyClean® is quick and effective for small and LIGHT soils, the Self Clean feature can be used to remove HEAVY, built up soils. The intensity and high heat of the Self Clean cycle may result in smoke which will require the opening up of windows to provide ventilation. Compared to the more intense Self Clean process, your LG oven gives you the option of cleaning with LESS HEAT, LESS TIME, and virtually NO SMOKE OR FUMES.

When needed, the range still provides the Self Clean option for longer, more thorough oven cleaning for heavier, built up soils.

Benefits of EasyClean®

- Helps loosen light soils before hand-cleaning
- EasyClean® only uses water; no chemical cleaners
- Makes for a better self-clean experience
 - Delays the need for a self-clean cycle
 - Minimizes smoke and odors
 - Can allow shorter self-clean time

When to Use EasyClean®

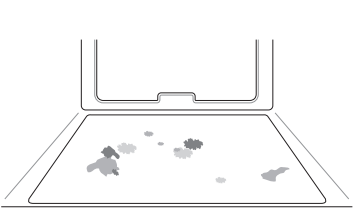
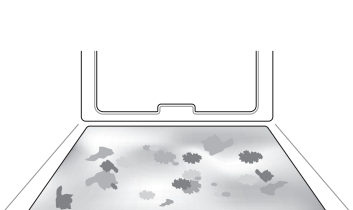
Suggested Cleaning Method	Example of Oven Soiling	Soil Pattern	Types of Soils	Common Food Items That Can Soil Your Oven
EasyClean®		Small drops or spots	Cheese or other ingredients	Pizza
		Light splatter	Fat/grease	Steaks, broiled
				Fish, broiled
				Meat roasted at low temperatures
Self Clean*		Medium to heavy splatter	Fat/grease	Meat roasted at high temperatures
		Drops or spots	Filling or sugar based soils	Pies
			Cream or tomato sauce	Casseroles

* The Self Clean cycle can be used for soil that has been built up over time.

EasyClean® Instruction Guide

- 1 Remove oven racks and accessories from the oven.
- 2 Scrape off and remove any burnt-on debris with a plastic scraper.

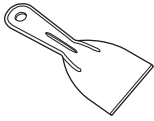

Suggested plastic scrapers:

- Hard plastic spatula
- Plastic pan scraper
- Plastic paint scraper
- Old credit card

- 3 Fill a spray bottle with $\frac{2}{5}$ (4 oz or 120 ml) of water and use the spray bottle to thoroughly spray the inside surfaces of the oven.
- 4 Use at least 2 oz or 60 ml of the water to completely saturate the soil on both the walls and in the corners of the oven. Spray or pour the remaining water onto the bottom center of the oven cavity.

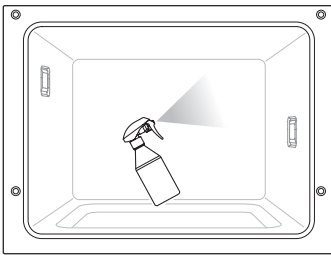

- 5 Fill and spray or pour the remaining 10 oz or 300 ml of water onto the bottom center of the oven cavity. The indentation on the oven bottom should be fully covered to submerge all soils. Add water if necessary.

NOTE

Use the "mist" setting on the spray bottle for better coverage. The entire 14 oz or 410 ml of water should be used for each oven cavity cleaned. Do not spray water directly on the door. Doing so will result in water dripping to the floor.

- 6 Close the door. Touch Clean, EasyClean® and Start in that order.
- 7 Swipe the LCD display and touch the **Cleaning** in the main screen. Then select **Easyclean** and touch **Start**.

CAUTION

- Some surfaces may be hot after the EasyClean® cycle. Wear rubber gloves while cleaning to prevent burns.
- During the EasyClean® cycle, the oven may become hot enough to cause burns. After the cycle ends, open the oven door and wait 5 minutes before wiping the inside surface of the oven. Failure to do so may result in burns.
- Avoid leaning or resting on the oven door glass while cleaning the oven cavity.

- 8 A tone will sound at the end of the 10 minute cycle. Touch **Done** to clear the display and end the tone.
- 9 After the cleaning cycle and during hand-cleaning, enough water should remain on the oven bottom to completely submerge all soils. Add water if necessary. Place a towel on the floor in front of the oven to capture any water that may spill out during hand-cleaning.
- 10 Clean the oven cavity immediately after the EasyClean® cycle by scrubbing with a wet, non-scratch scouring sponge or pad. (The scouring side will not scratch the finish.)

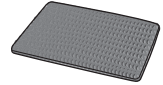

NOTE

Do not use any steel scouring pads, abrasive pads or cleaners as these materials can permanently damage the oven surface.

- 11 Once the oven cavity is cleaned, wipe any excess water with a clean dry towel. Replace racks and any other accessories.
- 12 If some light soils remain, repeat the above steps, making sure to thoroughly soak the soiled areas. If stubborn soils remain after multiple EasyClean® cycles, run the Self Clean cycle. Be sure that the oven cavity is empty of oven racks and other accessories, and that the oven cavity surface is dry before running the Self Clean cycle. Consult the Self Clean section of your owner's manual for further details.

NOTE

- If you forget to saturate the inside of the oven with water before starting EasyClean®, press Stop to end the cycle. Wait for the range to cool to room temperature and then spray or pour water into the oven and start another EasyClean® cycle.
- The cavity gasket may be wet when the EasyClean® cycle finishes. This is normal. Do not clean the gasket.
- If mineral deposits remain on the oven bottom after cleaning, use a cloth or sponge soaked in vinegar to remove them.
- It is normal for the fan to operate during the EasyClean® cycle.
- Using commercial oven cleaners or bleach to clean the oven is not recommended. Instead, use a mild liquid cleanser with a pH value below 12.7 to avoid discoloring the enamel.

Cleaning Tips

- Allow the oven to cool to room temperature before using the EasyClean® cycle.
- A plastic spatula can be used as a scraper to scrape off any chunks or debris before and during oven cleaning.
- Using the rough side of a non-scratch scouring pad may help to take off burnt-on stains better than a soft sponge or towel.
- Certain non-scratch scrubbing sponges, such as those made of melamine foam, available at your local stores, can also help improve cleaning.
- Make sure the range is level for best results when cleaning the oven.
- For best results, use distilled or filtered water. Tap water may leave mineral deposits on the oven bottom.
- If the soil inside the oven cannot be removed with warm, soapy water, use an alkaline cleaner like baking soda or borax.
- Soil baked on through several cooking cycles will be more difficult to remove with the EasyClean® cycle.
- Do not open the oven door during the EasyClean® cycle. Water will not get hot enough if the door is opened during the cycle.
- The self-clean cycle is better for cleaning hard to reach areas such as the back of the oven cavity.

Self Clean

The Self Clean cycle uses extremely hot temperatures to clean the oven cavity. While running the Self Clean cycle, you may notice smoking or an odor. This is normal; especially if the oven is heavily soiled.

During Self Clean, the kitchen should be well ventilated to minimize the odors from cleaning.

Before Starting Self Clean

- Remove the oven racks, broiler pan, broiler grid, oven rack guides, all cookware, aluminum foil or any other material from the oven.
- The kitchen should be well ventilated to minimize the odors from cleaning.
- Wipe any heavy spillovers on the bottom of the oven.

Removing the Rack Guides

Before starting Self Clean, you must remove the rack guides.

- 1 Open the oven door.
- 2 Turn the 2 bolts on each rack guide counterclockwise to remove the guides.

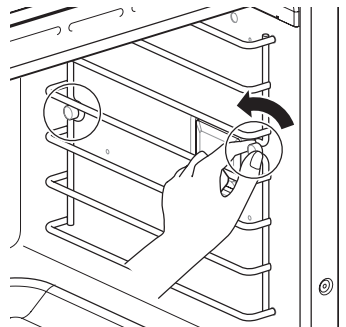

CAUTION

- Do not leave small children unattended near the appliance. During the Self Clean cycle, the outside of the range can become very hot to the touch.
- If you have pet birds, move them to another well-ventilated room. The health of some birds is extremely sensitive to the fumes given off during the Self Clean cycle of any range.
- Do not line the oven walls, racks, bottom or any other part of the range with aluminum foil or any other material. Doing so will destroy heat distribution, produce poor baking results and cause permanent damage to the oven interior (aluminum foil will melt to the interior surface of the oven).
- Do not force the door open. This can damage the automatic door locking system. Use care when opening the oven door after the Self Clean cycle. Stand to the side of the oven when opening the door to allow hot air or steam to escape. The oven may still be VERY HOT.
- During a Self Clean cycle, the cooktop elements cannot be used.

NOTE



- Remove oven racks and accessories before starting the Self Clean cycle. Remove rack guides from the oven. See "Removing Rack Guides."
- If oven racks are left in the oven cavity during the Self Clean cycle, they will discolor and become difficult to slide in and out.
- Clean the frame of the oven and door with hot soapy water. Rinse well.
- Do not clean the gasket. The fiberglass material of the oven door gasket cannot withstand abrasion. It is essential for the gasket to remain intact. If you notice it becoming worn or frayed, have it replaced.
- Wipe up any heavy spillovers on the oven bottom.
- It is normal for the fan to operate during the Self Clean cycle.
- If the Self Clean cycle is started the gas cooktop must be turned off or the self clean will turn off after 1 minute.

Setting Self Clean

The Self Clean function has cycle times of 3, 4 or 5 hours.

Self Clean Soil Guide

Soil Level	Cycle Setting
Lightly Soiled Oven Cavity	3-Hour Self Clean
Moderately Soiled Oven Cavity	4-Hour Self Clean
Heavily Soiled Oven Cavity	5-Hour Self Clean

- 1 Swipe the LCD display and touch **Cleaning** in the main screen. Then select **Selfclean**.
- 2 Select the desired cycle time.
- 3 If desired, scroll to set a delayed start time or touch the number pad icon  to enter the start time directly.
- 4 Touch **Start**. Read through the instructions in the display and touch **OK**. The remaining time or the delayed start time appears in the display.
- 5 Once the self-clean cycle is set, the oven door locks automatically and the lock icon  displays.

You will not be able to open the oven door until the oven has cooled. The lock releases automatically when the oven has cooled.

CAUTION

- Do not force the oven door open when the lock icon is displayed. The oven door remains locked until the oven temperature has cooled. Forcing the door open will damage the door.

NOTE

It may become necessary to cancel or interrupt a Self Clean cycle due to excessive smoke or fire in the oven. To cancel the Self Clean function, touch the **STOP** or **POWER** button at the left side of the display.

During Self Clean

- The Self Clean cycle uses extremely hot temperatures to clean the oven cavity. While running the Self Clean cycle, you may notice smoking or an odor. This is normal, especially if the oven is heavily soiled.
- As the oven heats, you may hear sounds of metal parts expanding and contracting. This is normal and will not damage the oven.
- Do not force the oven door open when the lock  is displayed. The oven door remains locked until the oven temperature has cooled. Forcing the door open will damage the door.

After the Self Clean Cycle

- The oven door remains locked until the oven temperature has cooled.
- You may notice some white ash in the oven. Wipe it off with a damp cloth or a soap-filled steel wool pad after the oven cools. If the oven is not clean after one self-clean cycle, repeat the cycle.
- If oven racks were left in the oven and do not slide smoothly after a self-clean cycle, wipe racks and rack supports with a small amount of vegetable oil to make them glide more easily.
- Fine lines may appear in the porcelain because it went through heating and cooling. This is normal and will not affect performance.

NOTE

- The Self Clean cycle cannot be started if the Lockout feature is active.
- Once the Self Clean cycle is set, the oven door locks automatically. You will not be able to open the oven door until the oven has cooled. The lock releases automatically.
- Once the door has been locked, the Door lock icon  appears at the top of the display. Allow about 15 seconds for the oven door lock to activate.
- If the clock is set for a 12-hour display (default) the Delayed Self Clean can never be set to start more than 12 hours in advance.
- After the oven is turned off, the convection fan keeps operating until the oven has cooled down.

Oven Air Vents

Air openings are located at the rear of the cooktop, at the top of the oven door, at the front of oven cavity and at the bottom of the range.

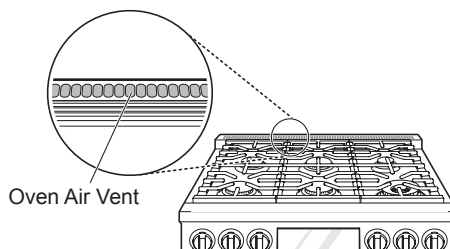

CAUTION

- **The edges of the range vent are sharp.** Wear gloves when cleaning the range to avoid injury.
- Clean ventilating hoods frequently. Grease should not be allowed to accumulate on the hood or filter.

NOTE

Do not block the vents and air openings of the range. They provide the air inlet and outlet that are necessary for the range to operate properly with correct combustion.

Adjusting Oven Door Handle

There are two screws, one located underneath each end of the handle.

If the handle is loose or wobbly, use a 1/16" or 2.3 mm hex wrench and turn it clockwise to tighten it.

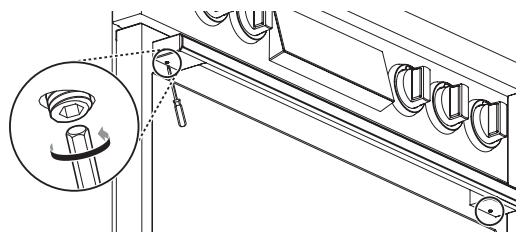

Removing and Replacing the Lift-Off Oven Doors

NOTE

- Parts may be changed due to product improvement and may look different than shown in images.

CAUTION

- Be careful when removing and lifting the door.
- Do not lift the door by the handle. The handle is not designed to support the weight of the door and could break.

Removing the Door

- 1 Fully open the door.
- 2 Unlock the hinge on both sides, rotating them as far toward the open door frame as they will go.

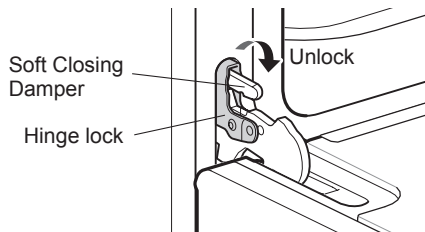

- 3 Firmly grasp both sides of the door at the top.
- 4 Close the door to the removal position (approximately 30 degrees) which is halfway between the broil stop position and fully closed. If the position is correct, the hinge cams will move freely.

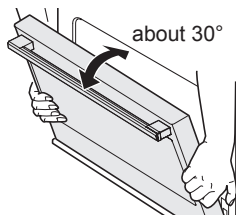

- 5 Lift door up and out until the hinge cams are clear of the slots.

Replacing the Door

- 1 Firmly grasp both sides of the door at the top.
- 2 With the door at the same angle as the removal position, seat the indentation of the hinge cams into the bottom edge of the hinge slots. The notch in the hinge cams must be fully seated into the bottom edge of the slots.

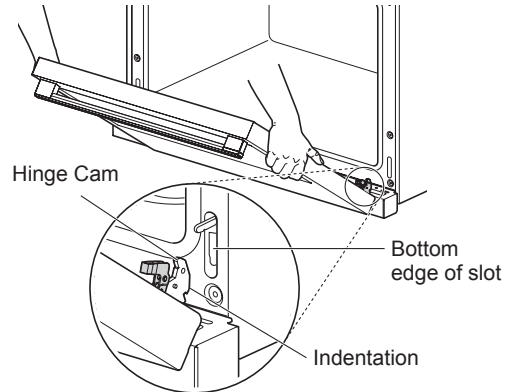

- 3 Open the door fully. If the door will not open fully, the indentation is not seated correctly in the bottom edge of the slots.
- 4 Lock the hinges on either side of the door, rotating them back toward the slots in the oven frame until they lock.

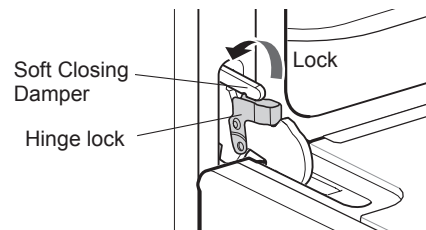

- 5 Close the oven door.

Door Care Instructions

Most oven doors contain glass that can break.

CAUTION

- Do not close the oven door until all the oven racks are fully in place.
- Do not hit the glass with pots, pans, or any other object.
- Scratching, hitting, jarring, or stressing the glass may weaken its structure causing an increased risk of breakage at a later time.

TROUBLESHOOTING

FAQs

What types of cookware are recommended for use with the cooktop?

- The pans must have a flat bottom and straight sides.
- Only use heavy-gauge pans.
- The pan size must match the amount of food to be prepared and the size of the surface element.
- Use tight fitting lids.

Why do the heating elements appear to be turning ON and OFF during use of the cooktop or oven?

Depending on your cooktop element setting or the temperature selected in your oven, it is NORMAL for the cooking elements to cycle on and off.

My new oven doesn't cook like my old one. Is there something wrong with the temperature settings?

No, your oven has been factory tested and calibrated. For the first few uses, follow your recipe times and temperatures carefully. If you still think your new oven is too hot or too cold, you can adjust the oven temperature yourself to meet your specific cooking needs. Refer to the Thermostat Adjustment section in this manual for easy instructions on how to adjust your thermostat.

Is it normal to hear a clicking noise coming from the back of my oven when I am using it?

Your new range is designed to maintain a tighter control over your oven's temperature. You may hear your oven's heating elements click on and off more frequently on your new oven. This is NORMAL.

During convection cooking the fan stops when I open the door. Is that normal?

Yes, this is normal. When the door is opened, the convection fan will stop until the door is closed.

Can I use aluminum foil to catch drippings in my oven cavity?

Never use aluminum foil to line the bottom or sides of the oven. The foil will melt and stick to the bottom surface of the oven and will not be removable. Use a sheet pan placed on a lower oven rack to catch drippings instead. (If foil has already melted onto the bottom of the oven, it will not interfere with the oven's performance.)

Can I use aluminum foil on the racks?

Do not cover racks with aluminum foil. Covering entire racks with foil restricts air flow, leading to poor cooking results. Use a sheet pan lined with foil under fruit pies or other acidic or sugary foods to prevent spillovers from damaging the oven finish.



CAUTION

Foil may be used to wrap food in the oven, but do not allow the foil to come into contact with the exposed broiling elements in the oven. The foil could melt or ignite, causing smoke, fire, or injury.



Can I leave my racks and rack guides in the oven when running a Self Clean cycle?

No. Although it will not damage the racks, it will discolor them and may make them hard to slide in and out during use. Remove all items from the oven before starting a Self Clean cycle.

What should I do if my racks are sticky and have become hard to slide in and out?

Over time, the racks may become hard to slide in and out. Apply a small amount of olive oil to the ends of the racks. This will work as a lubricant for easier gliding.

Why aren't the function buttons working?

Make sure that the range is not in Control Lock or idle mode. The lock  will show in the display if Control Lock is activated. To deactivate Control Lock, tap display to see the unlock popup. Press the lock icon  for 3 seconds to cancel the lockout function. If the display is in idle mode (blank or turned off), touch the LCD display to activate the screen.

My range is still dirty after running the EasyClean® cycle. What else should I do?

The EasyClean® cycle only helps to loosen light soils in your oven range to assist in hand-cleaning of your oven. It does not automatically remove all soils after the cycle. Some scrubbing of your oven range is required after running the EasyClean® cycle.

I tried scrubbing my oven after running EasyClean®, but some soils still remain. What can I do?

The EasyClean® feature works best when the soils are fully soaked and submerged in water before running the cycle and during hand-cleaning. If soils are not sufficiently soaked in water, it can negatively affect the cleaning performance. Repeat the EasyClean® process using sufficient water.

Sugar-based and certain greasy soils are especially hard to clean. If some stubborn soil remains in the oven, use the Self Clean feature to thoroughly clean your oven.

Soil on my oven walls is not coming off. How can I get the oven walls clean?

Soil on the side and rear walls of your oven range may be more difficult to fully soak with water. Try repeating the EasyClean® process.

Will EasyClean® get all of the soil and stains out completely?

It depends on the soil type. Sugar-based and certain grease stains are especially hard to clean. Also, if stains are not sufficiently soaked in water, this can negatively affect cleaning performance.

If stubborn or built-up stains remain in the oven, use the Self Clean feature. Refer to the Self Clean section of this owner's manual.

Are there any tricks to getting some of the stubborn soils out?

Scraping soils with a plastic scraper before and during hand-cleaning is recommended. Fully saturating soils with water is also recommended.

However, certain types of soil are harder to clean than others. For stubborn soils, the Self Clean cycle is recommended. However, self clean only works in the oven. Consult the Self Clean section of your owner's manual for details.

Is it safe for my convection fan, broil burner or heater element to get wet during EasyClean®?

Yes. The convection fan and broiler heater element may get a little wet during cleaning. However, direct spray onto the broil burner and heater elements is not necessary because these are self-cleaning during regular use.

I see smoke coming out of my oven range's cooktop vents during EasyClean®. Is this normal?

This is normal. This is not smoke. It is actually water vapor (steam) from the water in the oven cavity. As the oven heats briefly during EasyClean®, the water in the cavity evaporates and escapes through the oven vents.

How often should I use EasyClean®?

EasyClean® can be performed as often as you wish. EasyClean® works best when your oven is LIGHTLY soiled from such things as LIGHT grease splatter and small drops of cheese. Please refer to the EasyClean® section in your owner's manual for more information.

Before Calling for Service



Before you call for service, review this list. It may save you time and expense. The list includes common occurrences that are not the result of defective workmanship or materials in this appliance.

For detailed information or videos, visit www.lg.com for the troubleshooting page.

Symptoms	Possible Causes / Solutions
Range is not level.	<ul style="list-style-type: none"> • Poor installation. Place oven rack in center of oven. Place a level on the oven rack. Adjust leveling legs at base of range until the oven rack is level. • Be sure floor is level and strong and stable enough to adequately support range. • If floor is sagging or sloping, contact a carpenter to correct the situation. • Kitchen cabinet alignment may make range appear unlevel. Be sure cabinets are square and have sufficient room for range clearance.
Cannot move appliance easily. Appliance must be accessible for service.	<ul style="list-style-type: none"> • Cabinets not square or are built in too tightly. Contact builder or installer to make appliance accessible. • Carpet interferes with range. Provide sufficient space so range can be lifted over carpet. • Anti-tip device engaged.
Oven control beeps and displays failure error code.	<ul style="list-style-type: none"> • Electronic control error. Press OK to clear the display and stop beeping. Reprogram oven. If fault recurs, record fault number. Press OK and contact a Service agent.
Gas cooktop burners do not light or do not burn evenly.	<ul style="list-style-type: none"> • Make sure that the electrical plug is inserted into a live, properly grounded outlet. • Remove the burners and clean them. Check the electrode area for burnt on food or grease. See Cleaning Burner Heads/Caps in the MAINTENANCE section. • Make sure that the burner parts are installed correctly. See Removing and Replacing the Gas Surface Burners in the MAINTENANCE section.
Burner flames are very large or yellow.	<p>If the range is connected to LP gas, contact the technician who installed your range or made the conversion.</p>
Oven will not work	<ul style="list-style-type: none"> • Plug on range is not completely inserted in the electrical outlet. <ul style="list-style-type: none"> - Make sure electrical plug is plugged into a live, properly grounded outlet. • A fuse in your home may be blown or the circuit breaker tripped. <ul style="list-style-type: none"> - Replace the fuse or reset the circuit breaker. • Oven controls improperly set. <ul style="list-style-type: none"> - See the Using the Oven section. • Oven too hot. <ul style="list-style-type: none"> - Allow the oven to cool to below locking temperature.
Appliance does not operate.	<ul style="list-style-type: none"> • Make sure cord is plugged correctly into outlet. Check circuit breakers. • Service wiring is not complete. Contact your electrician for assistance. • Power outage. Check house lights to be sure. Call your local electric company for service.
Oven light does not work.	<ul style="list-style-type: none"> • This oven uses halogen lamp which must be repaired or replaced by an authorized technician.

Symptoms	Possible Causes / Solutions
Oven smokes excessively during broiling.	<ul style="list-style-type: none"> • Control not set properly. Follow instructions under Setting Oven Controls. • Meat too close to the element. Reposition the rack to provide proper clearance between the meat and the element. Preheat broil element for searing. • Meat not properly prepared. Remove excess fat from meat. Cut remaining fatty edges to prevent curling. • Insert on broiler pan wrong side up and grease not draining. Always place grid on the broiler pan with ribs up and slots down to allow grease to drip into pan. • Grease has built up on oven surfaces. Regular cleaning is necessary when broiling frequently. <ul style="list-style-type: none"> - Old grease or food spatters cause excessive smoking.
Food does not bake or roast properly	<ul style="list-style-type: none"> • Oven controls improperly set. <ul style="list-style-type: none"> - See the Using the Oven section. • Oven not preheated before cooking. <ul style="list-style-type: none"> - For proper results when baking or roasting, allow the oven to finish preheating and come up to the set temperature before placing food in the oven. • Rack position is incorrect or the rack is not level. <ul style="list-style-type: none"> - See the Using the Oven section. • Incorrect cookware or cookware of improper size being used. <ul style="list-style-type: none"> - See the Using the Oven section. • Oven sensor needs to be adjusted. <ul style="list-style-type: none"> - See Thermostat Adjustment in the Features section.
Food does not broil properly	<ul style="list-style-type: none"> • Improper rack position being used. <ul style="list-style-type: none"> - See the Broiling Guide. • Cookware not suited for broiling. <ul style="list-style-type: none"> - Use broiling pan and grid. • Aluminum foil used on the broiling pan and grid has not been fitted properly and slit as recommended. <ul style="list-style-type: none"> - See the Using the Oven section. • In some areas the power voltage may be low. <ul style="list-style-type: none"> - Preheat the broil element for 5-7 minutes. - See the Broiling Guide.
Oven temperature too hot or too cold	<ul style="list-style-type: none"> • Oven sensor needs to be adjusted. <ul style="list-style-type: none"> - See Thermostat Adjustment in the Settings section.
Oven will not Self Clean	<ul style="list-style-type: none"> • The oven temperature is too high to set a Self Clean operation. <ul style="list-style-type: none"> - Allow the range to cool and reset the controls. • Oven controls improperly set. <ul style="list-style-type: none"> - See the Self Clean section. • A Self Clean cycle cannot be started if the oven lockout feature is active.
“Crackling” or “popping” sound	<ul style="list-style-type: none"> • This is the sound of the metal heating and cooling during both the cooking and Self Clean functions. <ul style="list-style-type: none"> - This is normal.

92 TROUBLESHOOTING

Symptoms	Possible Causes / Solutions
Fan noise	<ul style="list-style-type: none"> • A convection fan may automatically turn on and off. <ul style="list-style-type: none"> - This is normal. • The fans that exist to cooling for the range are turned on and off according to the temperature of the range. <ul style="list-style-type: none"> - This is normal.
Convection fan stops	<ul style="list-style-type: none"> • Convection fan stops according to cook mode. <ul style="list-style-type: none"> - This is normal and is done to allow for more even heating during the cycle. This is not a failure of the range and should be considered normal operation.
Excessive smoking during a Self Clean cycle	<ul style="list-style-type: none"> • Excessive soil. <ul style="list-style-type: none"> - Press the STOP button. Open the windows to rid the room of smoke. Wait until the Self Clean mode is cancelled. Wipe up the excess soil and reset the clean.
Oven door does not open after a Self Clean cycle	<ul style="list-style-type: none"> • Oven is too hot. <ul style="list-style-type: none"> - Allow the oven to cool below locking temperature. • Allow about one hour for the oven to cool after the completion of a Self Clean cycle. The door can be opened when the lock  is no longer displayed. • The control and door may be locked.
The oven is not clean after a Self Clean cycle	<ul style="list-style-type: none"> • Oven controls not properly set. <ul style="list-style-type: none"> - See the Self Clean section. • Oven was heavily soiled. <ul style="list-style-type: none"> - Clean up heavy spillovers before starting the clean cycle. Heavily soiled ovens may need to Self Clean again or for a longer period of time.
Door locked icon  shows in the display when you want to cook	<ul style="list-style-type: none"> • The oven door is locked because the temperature inside the oven has not dropped below the locking temperature. <ul style="list-style-type: none"> - Press the STOP button. Allow the oven to cool.
Burning or oily odor emitting from the vent	<ul style="list-style-type: none"> • This is normal in a new oven and will disappear in time. <ul style="list-style-type: none"> - To speed the process, set a Self Clean cycle for a minimum of 3 hours. See the Self Clean section.
Oven racks are difficult to slide	<ul style="list-style-type: none"> • The shiny, silver-colored racks were cleaned in a Self Clean cycle. <ul style="list-style-type: none"> - Apply a small amount of vegetable oil to a paper towel and wipe the edges of the oven racks with the paper towel.

Symptoms	Possible Causes / Solutions
Trouble connecting appliance and smartphone to Wi-Fi network	<ul style="list-style-type: none">• The password for the Wi-Fi network was entered incorrectly.<ul style="list-style-type: none">- Delete your home Wi-Fi network and begin the registration process again.• Mobile data for your smartphone is turned on.<ul style="list-style-type: none">- Turn off the Mobile data on your smartphone before registering the appliance.• The wireless network name (SSID) is set incorrectly.<ul style="list-style-type: none">- The wireless network name (SSID) should be a combination of English letters and numbers. (Do not use special characters.)• The router frequency is not 2.4 GHz.<ul style="list-style-type: none">- Only a 2.4 GHz router frequency is supported. Set the wireless router to 2.4 GHz and connect the appliance to the wireless router. To check the router frequency, check with your Internet service provider or the router manufacturer.• The distance between the appliance and the router is too far.<ul style="list-style-type: none">- If the appliance is too far from the router, the signal may be weak and the connection may not be configured correctly. Move the router closer to the appliance or purchase and install a Wi-Fi repeater.

LIMITED WARRANTY

USA

TERMS AND CONDITIONS

ARBITRATION NOTICE: THIS LIMITED WARRANTY CONTAINS AN ARBITRATION PROVISION THAT REQUIRES YOU AND LG ELECTRONICS ("LG") TO RESOLVE DISPUTES BY BINDING ARBITRATION INSTEAD OF IN COURT, UNLESS YOU CHOOSE TO OPT OUT. IN ARBITRATION, CLASS ACTIONS AND JURY TRIALS ARE NOT PERMITTED. PLEASE SEE THE SECTION TITLED "PROCEDURE FOR RESOLVING DISPUTES" BELOW.

Should your **LG** Gas Range ("Product") fail due to a defect in materials or workmanship under normal and proper use, during the warranty period set forth below, **LG** will, at its option, repair or replace the Product. This limited warranty is valid only to the original retail purchaser of the Product and applies only when purchased lawfully and used within the United States including U.S. Territories.

Warranty Period	Scope of Warranty	HOW SERVICE IS HANDLED
Two (2) years from the date of original retail purchase, or from the date of delivery as per applicable law	Parts and Labor (internal / functional parts only)	LG will provide, free of charge, all labor and in-home service to replace defective part(s).

- Replacement Products and parts are warranted for the remaining portion of the original warranty period or ninety (90) days, whichever is greater.
- Replacement Products and parts may be new, reconditioned, refurbished, or otherwise factory remanufactured.
- Replaced Product or part(s) will be the property of **LG**.
- Proof of original retail purchase specifying the Product model and date of purchase is required to obtain warranty service under this limited warranty.

EXCEPT TO THE EXTENT PROHIBITED BY APPLICABLE LAW, ANY IMPLIED WARRANTY OF MERCHANTABILITY OR FITNESS FOR A PARTICULAR PURPOSE ON THE PRODUCT IS LIMITED IN DURATION TO THE DURATION OF THE ABOVE LIMITED WARRANTY. UNDER NO CIRCUMSTANCES SHALL LG OR ITS U.S. DISTRIBUTORS/DEALERS BE LIABLE FOR ANY INDIRECT, INCIDENTAL, CONSEQUENTIAL, SPECIAL, OR PUNITIVE DAMAGES, INCLUDING, WITHOUT LIMITATION, LOST GOODWILL, LOST REVENUES OR PROFITS, WORK STOPPAGE, IMPAIRMENT OF OTHER GOODS, COST OF REMOVAL AND REINSTALLATION OF THE PRODUCT, LOSS OF USE, OR ANY OTHER DAMAGES WHETHER BASED IN CONTRACT, TORT, OR OTHERWISE. LG'S TOTAL LIABILITY, IF ANY, SHALL NOT EXCEED THE PURCHASE PRICE PAID BY YOU FOR THE PRODUCT.

SOME STATES DO NOT ALLOW THE EXCLUSION OR LIMITATION OF INCIDENTAL OR CONSEQUENTIAL DAMAGES OR LIMITATIONS ON HOW LONG AN IMPLIED WARRANTY LASTS, SO THE ABOVE EXCLUSIONS OR LIMITATIONS MAY NOT APPLY TO YOU. THIS LIMITED WARRANTY GIVES YOU SPECIFIC LEGAL RIGHTS AND YOU MAY ALSO HAVE OTHER RIGHTS THAT VARY FROM STATE TO STATE.

THIS LIMITED WARRANTY DOES NOT COVER:

- Service trips to deliver, pick up, or install, educate how to operate, correct wiring, or correct unauthorized repairs.
- Damage or failure of the Product to perform during power failures and interrupted or inadequate electrical service.
- Damage or failure caused by leaky or broken water pipes, frozen water pipes, restricted drain lines, inadequate or interrupted water supply or inadequate supply of air.
- Damage resulting from operating the product in a corrosive atmosphere or contrary to the product owner's manual.
- Damage or failure to the Product caused by accidents, pests and vermin, lightning, wind, fire, floods, acts of God, or any other causes beyond the control of **LG**.

- Damage or failure of the Product caused by unauthorized modification or alteration, or if the Product is used for other than the intended purpose, or any water leakage where the Product was not properly installed.
- Damage or failure of the Product caused by incorrect electrical current, voltage, or plumbing codes.
- Damage or failure of the Product caused by transportation, storage, and/or handling, including scratches, dents, chips, and/or other damage to the finish of the Product, unless such damage is reported within one (1) week of delivery.
- Damage or failure of the Product resulting from misuse, abuse, improper installation, repair, or maintenance. Improper repair includes the use of parts not authorized by **LG**. Improper installation or maintenance includes installation or maintenance contrary to the Product owner's manual.
- Damage or failure of the Product caused by the use of parts, components, accessories, consumable cleaning products, or any other products or services that were not authorized by **LG**.
- Damage or missing items to any display or open box Product.
- Refurbished Product or any Product sold "As Is", "Where Is", "With all Faults", or similar disclaimer.
- Products with original serial numbers that have been removed, altered, or cannot be readily determined.
- Increases in utility costs and additional utility expenses.
- Any noises associated with normal operation.
- Products used for other than normal and proper household use (e.g., commercial or industrial use) or contrary to the Product owner's manual.
- Costs associated with removal and reinstallation of the Product for repairs, or the removal and reinstallation of the Product if it is installed in an inaccessible location or not installed in accordance with the Product Owner's manual.
- Accessories, removable components, or consumable parts (e.g. Shelves, door bins, drawers, water/air filters, racks, light bulbs, batteries, etc., as applicable), except for internal/functional parts covered under this limited warranty.

PROCEDURE FOR RESOLVING DISPUTES:

ALL DISPUTES BETWEEN YOU AND LG ARISING OUT OF OR RELATING IN ANY WAY TO THIS LIMITED WARRANTY OR THE PRODUCT SHALL BE RESOLVED EXCLUSIVELY THROUGH BINDING ARBITRATION, AND NOT IN A COURT OF GENERAL JURISDICTION. BINDING ARBITRATION MEANS THAT YOU AND LG ARE EACH WAIVING THE RIGHT TO A JURY TRIAL AND TO BRING OR PARTICIPATE IN A CLASS ACTION.

Definitions. For the purposes of this section, references to "LG" mean LG Electronics USA, Inc., its parents, subsidiaries and affiliates, and each of their officers, directors, employees, agents, beneficiaries, predecessors in interest, successors, assigns and suppliers; references to "dispute" or "claim" shall include any dispute, claim or controversy of any kind whatsoever (whether based in contract, tort, statute, regulation, ordinance, fraud, misrepresentation or any other legal or equitable theory) arising out of or relating in any way to the sale, condition or performance of the product or this Limited Warranty.

Notice of Dispute. In the event you intend to commence an arbitration proceeding, you must first notify LG in writing at least 30 days in advance of initiating the arbitration by sending a letter to LG at LG Electronics, USA, Inc. Attn: Legal Department- Arbitration 111 Sylvan Avenue, Englewood Cliffs, NJ 07632. You and LG agree to engage in good faith discussions in an attempt to amicably resolve your claim. The notice must provide your name, address, and telephone number; identify the product that is the subject of the claim; and describe the nature of the claim and the relief being sought. If you and LG are unable to resolve the dispute within 30 days, either party may proceed to file a claim for arbitration.

Agreement to Binding Arbitration and Class Action Waiver. Upon failure to resolve the dispute during the 30 day period after sending written notice to LG, you and LG agree to resolve any claims between us only by binding arbitration on an individual basis, unless you opt out as provided below. Any dispute between you and LG shall not be combined or consolidated with a dispute involving any other person's or entity's product or claim. More specifically, without limitation of the foregoing, any dispute between you and LG shall not under any circumstances proceed as part of a class or representative action. Instead of arbitration, either party may bring an individual action in small claims court, but that small claims court action may not be brought on a class or representative basis.

Arbitration Rules and Procedures. To begin arbitration of a claim, either you or LG must make a written demand for arbitration. The arbitration will be administered by the American Arbitration Association (“AAA”) and will be conducted before a single arbitrator under the AAA’s Consumer Arbitration Rules that are in effect at the time the arbitration is initiated (referred to as the “AAA Rules”) and under the procedures set forth in this section. The AAA Rules are available online at www.adr.org/consumer. Send a copy of your written demand for arbitration, as well as a copy of this provision, to the AAA in the manner described in the AAA Rules. You must also send a copy of your written demand to LG at LG Electronics, USA, Inc. Attn: Legal Department- Arbitration 111 Sylvan Avenue, Englewood Cliffs, NJ 07632. If there is a conflict between the AAA Rules and the rules set forth in this section, the rules set forth in this section will govern. This arbitration provision is governed by the Federal Arbitration Act. Judgment may be entered on the arbitrator’s award in any court of competent jurisdiction. All issues are for the arbitrator to decide, except that issues relating to the scope and enforceability of the arbitration provision and to the arbitrability of the dispute are for the court to decide. The arbitrator is bound by the terms of this provision.

Governing Law. The law of the state of your residence shall govern this Limited Warranty and any disputes between us except to the extent that such law is preempted by or inconsistent with applicable federal law.

Fees/Costs. You do not need to pay any fee to begin an arbitration. Upon receipt of your written demand for arbitration, LG will promptly pay all arbitration filing fees to the AAA unless you seek more than \$25,000 in damages, in which case the payment of these fees will be governed by the AAA Rules. Except as otherwise provided for herein, LG will pay all AAA filing, administration and arbitrator fees for any arbitration initiated in accordance with the AAA Rules and this arbitration provision. If you prevail in the arbitration, LG will pay your attorneys’ fees and expenses as long as they are reasonable, by considering factors including, but not limited to, the purchase amount and claim amount. Notwithstanding the foregoing, if applicable law allows for an award of reasonable attorneys’ fees and expenses, an arbitrator can award them to the same extent that a court would. If the arbitrator finds either the substance of your claim or the relief sought in the demand is frivolous or brought for an improper purpose (as measured by the standards set forth in Federal Rule of Civil Procedure 11(b)), then the payment of all arbitration fees will be governed by the AAA Rules. In such a situation, you agree to reimburse LG for all monies previously disbursed by it that are otherwise your obligation to pay under the AAA Rules. Except as otherwise provided for, LG waives any rights it may have to seek attorneys’ fees and expenses from you if LG prevails in the arbitration.



Hearings and Location. If your claim is for \$25,000 or less, you may choose to have the arbitration conducted solely on the basis of (1) documents submitted to the arbitrator, (2) through a telephonic hearing, or (3) by an in-person hearing as established by the AAA Rules. If your claim exceeds \$25,000, the right to a hearing will be determined by the AAA Rules. Any in-person arbitration hearings will be held at a location within the federal judicial district in which you reside unless we both agree to another location or we agree to a telephonic arbitration.

Opt Out. You may opt out of this dispute resolution procedure. If you opt out, neither you nor LG can require the other to participate in an arbitration proceeding. To opt out, you must send notice to LG no later than 30 calendar days from the date of the first consumer purchaser’s purchase of the product by either: (i) sending an e-mail to optout@lge.com, with the subject line: “Arbitration Opt Out” or (ii) calling 1- 800-980-2973. You must include in the opt out e-mail or provide by telephone: (a) your name and address; (b) the date on which the product was purchased; (c) the product model name or model number; and (d) the serial number (the serial number can be found (i) on the product; or (ii) online by accessing [https:// www.lg.com/us/support/repair-service/schedule-repair-continued](https://www.lg.com/us/support/repair-service/schedule-repair-continued) and clicking on “Find My Model & Serial Number”).

You may only opt out of the dispute resolution procedure in the manner described above (that is, by e-mail or telephone); no other form of notice will be effective to opt out of this dispute resolution procedure.

Opting out of this dispute resolution procedure will not affect the coverage of the Limited Warranty in any way, and you will continue to enjoy the full benefits of the Limited Warranty. If you keep this product and do not opt out, then you accept all terms and conditions of the arbitration provision described above.

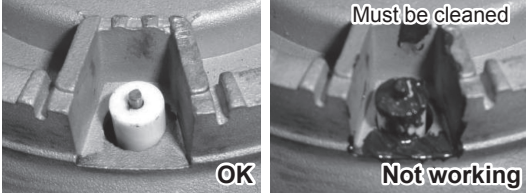
Not Covered by Warranty

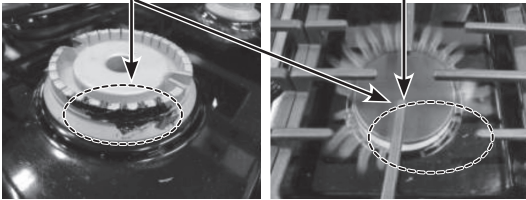
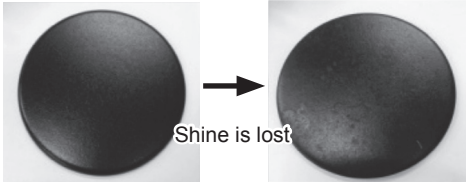
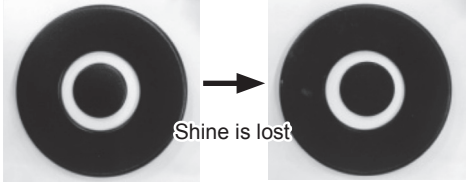
Problem	Cause	Prevention
<ul style="list-style-type: none"> Burners do not light 	<p>Clogged or dirty burner ports or electrodes will not allow the burner to operate properly</p> 	<ul style="list-style-type: none"> Check and clean the gas electrode.
<ul style="list-style-type: none"> Uneven flame 	<ol style="list-style-type: none"> Improper burner cap installation <p>Burner cap is properly seated. Burner cap is NOT properly seated.</p>  Burner ports clogged by food residue <p>Ports blocked by dirt Flames uneven</p>  	<ul style="list-style-type: none"> Check installation of burner head and cap Hardened residue should be removed using a toothbrush.
<ul style="list-style-type: none"> Burner cap is dull or has changed color 	<ol style="list-style-type: none"> Scratching Use of detergent or abrasive cleansers <p>Single burner cap</p>  <p>Dual burner cap</p> 	<ul style="list-style-type: none"> Do not use steel wool or abrasive cleansers to clean. To remove burnt-on food, soak the burner heads in hot water for 20–30 minutes. (Do not use detergent)

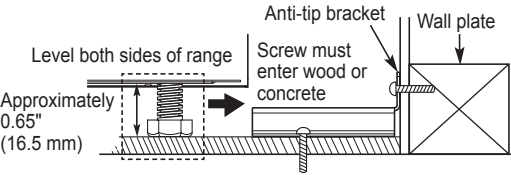
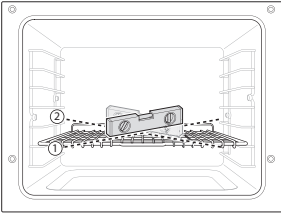
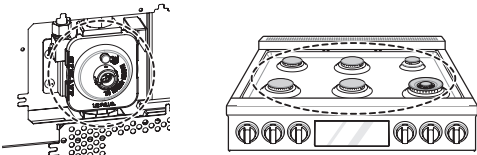
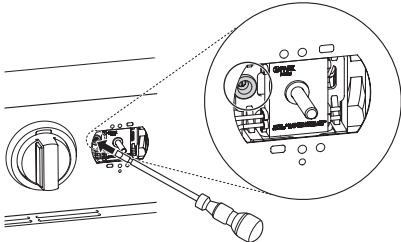
Problem	Cause	Prevention
<ul style="list-style-type: none"> Oven or racks are stained after using aluminum foil 	<p>Aluminum foil has melted in the oven</p> 	<ul style="list-style-type: none"> Never cover the oven bottom or cover an entire rack with materials such as aluminum foil. If the foil has already melted onto the oven, it will not affect the performance of the oven.
<ul style="list-style-type: none"> Surface is not level Oven is tipping 	<ol style="list-style-type: none"> Range not leveled Anti-tip device not installed correctly   <p>Use carpenter's level to check level.</p>	<ul style="list-style-type: none"> Check with installer first
<ul style="list-style-type: none"> Flames too big on converted cooktop (NP → LP) 	<p>The installer missed part of the conversion. (Check 2 parts: regulator, cooktop valve).</p>  <p>regulator cooktop valve</p>	<ul style="list-style-type: none"> Check with installer first Refer to installation manual
<ul style="list-style-type: none"> Flame is too small or too large 	<ol style="list-style-type: none"> Variable gas pressure Installer did not check  <p>Center adjustment screw</p>	<ul style="list-style-type: none"> Check with installer first

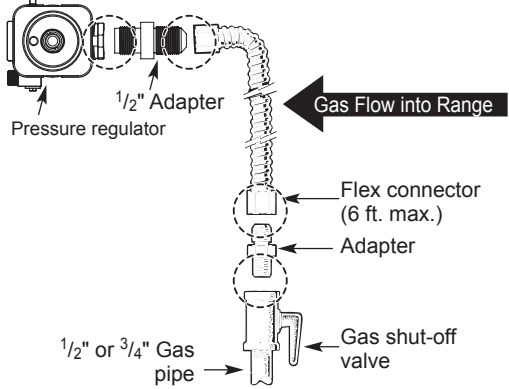
Problem	Cause	Prevention
<ul style="list-style-type: none"> Gas smell 	<p>Improper connection</p> <p>Flexible Connector Hookup</p> 	<ul style="list-style-type: none"> Check with installer first

The cost of repair or replacement under these excluded circumstances shall be borne by You.
 TO OBTAIN WARRANTY SERVICE AND ADDITIONAL INFORMATION
 Call 1-800-984-6306 and select the appropriate option from the menu.
 Or visit our website at <http://www.LGSIGNATURE.com>
 Or by mail: **LG** Customer Service P.O. Box 240007 Huntsville, AL 35813 ATTN: CIC

MEMO

LG SIGNATURE

Customer Information Center

For inquiries or comments, call:

1-800-984-6306 USA