

SAVALO

Service

MANUAL

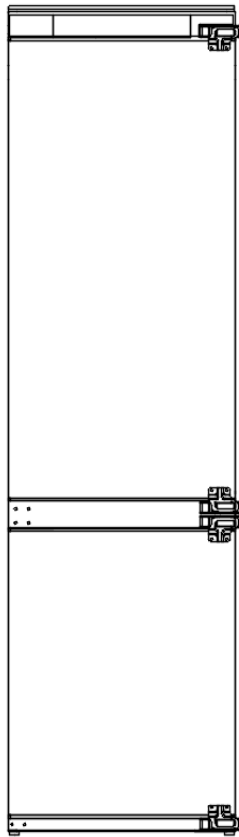

...

– Notice –

This Manual is prepared for the use of trained Service Technicians and should not be used by those not properly qualified. This Manual is not intended to be all-encompassing. You should read, in its entirety, the repair procedure you wish to perform to determine if you have the necessary tools, instruments, and skills required to perform the procedure. Procedures for which you do not have the necessary tools, instruments, and skills should be performed by a trained Service Technician.

Serial Number	3
Safety Information	4
Installation, Electrical & Plumbing Requirements	6
Theory of Operation	7
Refrigerator Components	8
Freezer Components	9
Rear & Compressor Area Components	11
Gas Flow Diagram & Parts	12
Electrical Components & Specifications	13
Display Panel Set Up Instructions	14
Error Codes & Control Board Connections	17
F2& F3	18
F4& F5	19
F6	20
CE	21
2E& DR	22
Maintenance guide for refrigeration failure & High Temp Error	23
Temperature to Resistance Chart	24
Wiring Diagram	25
Control Board Test Points	26
Main control board led flashing fault	27
Control Board	28
Display	29
Ice Maker	30
Sensor	31
Light Switch	32
LED Light	33
Refrigerator rail removal	34
Refrigerator the Rear Wall	35
Freezer the Rear Wall	36
Defrost Element & Thermal Fuse+	37
Troubleshooting	38

Serial Number

The serial tag is located on either the upper left-hand wall of the refrigerator section, or bottom of the compartment, beneath the large crisper drawer.



SAVE THESE INSTRUCTIONS

REVIEW ALL SERVICE INFORMATION IN THIS SERVICE MANUAL BEFORE BEGINNING REPAIRS.

This product should only be serviced by a qualified service technician, who is familiar with the standard safety procedures required for servicing this product. The technician should be equipped with the proper tools, parts, and test equipment before beginning.

Safety Information

We have provided many important safety messages in this manual and on the appliance. ALWAYS READ AND OBEY ALL SAFETY MESSAGES.

This is the safety alert symbol



This symbol alerts you to hazards that could cause death or injury to you or others, or cause damage to product or property. Each occurrence will identify the hazard, describe how to reduce the chance of injury, and describe what can happen if the instructions are not followed. The symbol will be surrounded by a color which corresponds to a particular type of hazard. Red for DANGER, Orange for WARNING, and Yellow for CAUTION.

These categories are defined in the boxes to the right

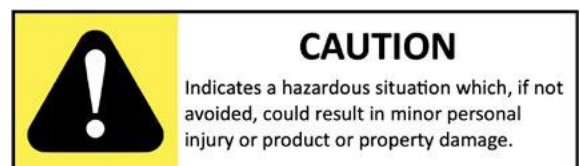
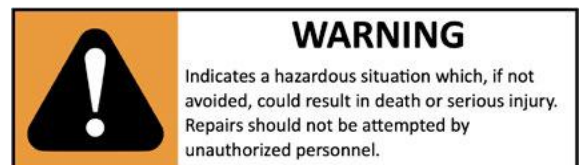
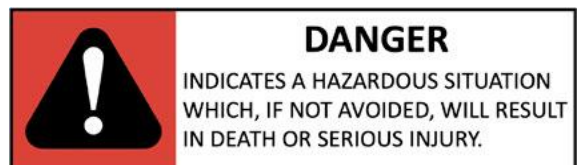

Safety Instructions

The manufacturer reserves the right to make changes in the technical specifications in order to improve the appliance quality without any prior notice. Figures included in this manual are for schematic purposes only and may not match the appliance exactly. Values stated on the markings of the appliance, or in other printed documents supplied with the appliance, are obtained under laboratory conditions as per relevant standards. These values may vary according to the usage of the appliance and ambient conditions.

Proper Installation - Be sure your appliance is properly installed and grounded by a qualified technician.

If the supplied electrical cord is damaged, it must be replaced by a power cord or assembly from the manufacturer. It must also be installed by a qualified service technician.



Service repairs must always be performed by an Authorized Servicer. Installations must be performed by a Certified Installer (This can include certified and licensed electrician or plumbers. The Manufacturer cannot be held responsible for damages caused by operations performed by unauthorized, un-certified or unlicensed persons.

- If the refrigerator is malfunctioning, it must not be operated until it is repaired by an Authorized Servicer. There is a risk of electrical shock!
- The unit should be plugged into a three-prong, grounded and polarized 10A, 110V, 60Hz dedicated wall outlet. Our company will not be responsible for damages incurred while using the product in a way that does not comply with the electrical code of the location where the product is installed.
- If the unit is not going to be used for an extended period of time, turn off the power to it via the circuit breaker, shut of the water supply, and leave the doors open.
- Never wash the refrigerator by spraying or pouring water on it. There is a risk of electric shock!
- Caution should be used when unplugging the unit for service. Make sure your hands are not wet, and always hold the plug when disconnecting from the outlet, not the cord. If the outlet is loose, have a licensed electrician repair or replace the outlet.
- This unit was designed to operate on a normal 60Hz, 110VAC electrical grid system. If it is connected to any energy saving system, alternative power, or solar power system, etc. and is experiencing any operational issues, please contact your local electrical provided for further information.
- Shut off power to the refrigerator at the circuit breaker during installation, cleaning near exposed electrical components, or service repairs.

Installation, Electrical & Plumbing Requirements

- The refrigerator must not be located too close to a heat source. Be sure it is installed at least 12" (30cm) from cooktops, ovens, radiators or stoves, and at least 2" (5cm) from electric ovens. Also, be sure the unit is not subject to direct sunlight or excessively humid locations.
- Do not install the refrigerator in place where the temperature falls below 50°F/10°C.
- Do not block the ventilation grill in the bottom to ensure proper ventilation (cooling air intake).



1 3/4" (4cm) between them.

- This product requires a 110VAC, 50Hz service.
- The electrical connection must comply with national regulations.
- Be sure power cable is accessible after installation.
- Do not make connections via extension cords or multi-plugs.
- Rated total current draw is 0.8A. A circuit breaker above this amount must be used, in compliance with local regulations.
- GFCI outlets will provide added protection, but any failure of the GFCI could cause food spoilage, which is not covered by the manufacturer's warranty.



WARNING: A damaged power cord must be replaced by an Authorized Service Technician.

Theory of Operation

Compressor & Evaporators

The refrigerator has one evaporators, but only one compressor, charged with R600a refrigerant.

Display

The Display is the operational interface for the customer. For information about each key and option, see the description below

Temperature Sensors

There are five thermistors on this product - One for the Special fridge (Air), One for the Chiller (Air), One for the Ambient Temperature Sensor, Two for the Freezer (Air & Evaporator). All of these sensors are NTC thermistors. Temperature information is transmitted to the main board via changes in their resistance. These thermistors ensure that the product operates according to the parameters set by the system software.

Heating Elements

There are one heating elements on this refrigerator - a Freezer Heater (evaporator), the maximum defrosting time is limited to less than 50 minutes. When the sensor detects the temperature $\geq 46^{\circ}\text{F}/8^{\circ}\text{C}$ during defrosting, the defrosting will be stopped. After defrosting, delay 5 minutes for the compressor to start, and 3 minutes for the fan to run after the compressor starts.

Fans

There are one fans on this product - a Freezer Fan 12VD. C

Ice Makers

There are a 115VAC motor twist the ice trays to eject the ice cubes.

A water valve is used to send water to the ice trays after each ice harvest. Use a flow meter to measure the amount of water. A solenoid on the main water valve assembly is energized for the time set by the system software.

Lights

12VDC LED light boards are used to illuminate fridge. Reed switches at the under of the doors activate the lights when a door is opened.

Controller

All the components listed above are operated by the Main Control Board located at the under of the product. Access to this, and all other components, is explained in the disassembly section of this manual.

Refrigerator Components



Refrigerator Components

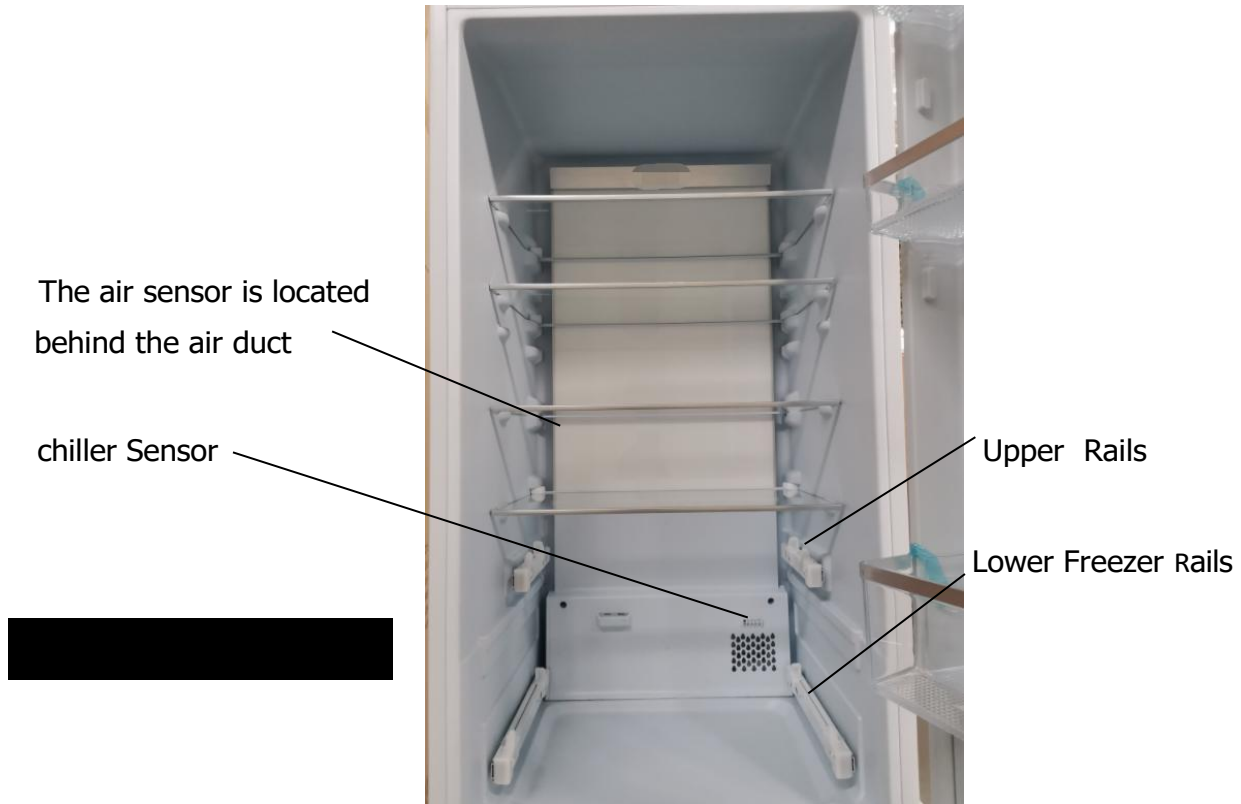

Freezer Components

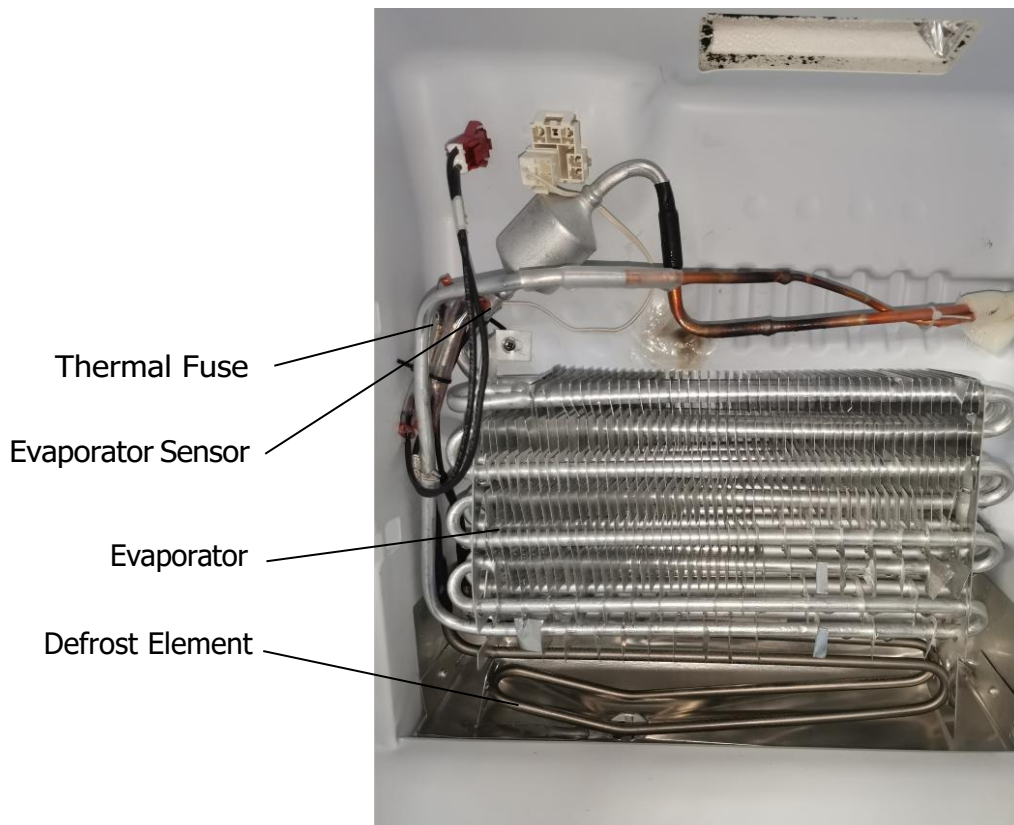
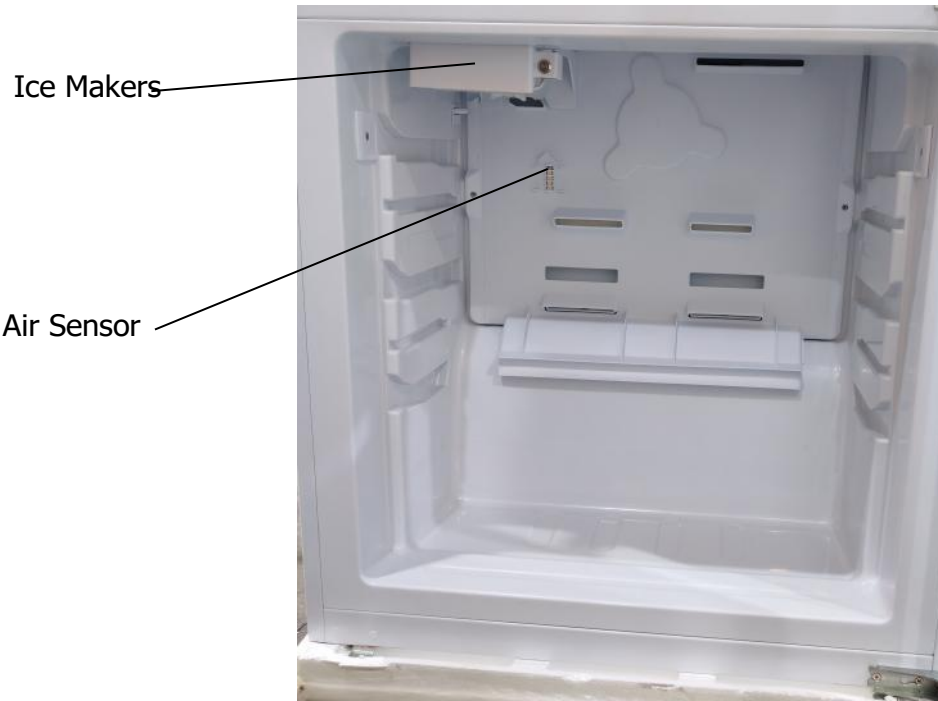

Rear & Compressor Area Components



Control board
epair from the lower left of the back



Water Valve



Compressor

Water connection box

Gas Flow Diagram & Parts



This refrigerator utilizes a cooling system using R600a refrigerant. Take care to avoid damaging the cooling system and its pipes while using and moving the unit. This gas is flammable. If the cooling system is damaged, keep the unit away from potential sources of fire and ventilate the room immediately.

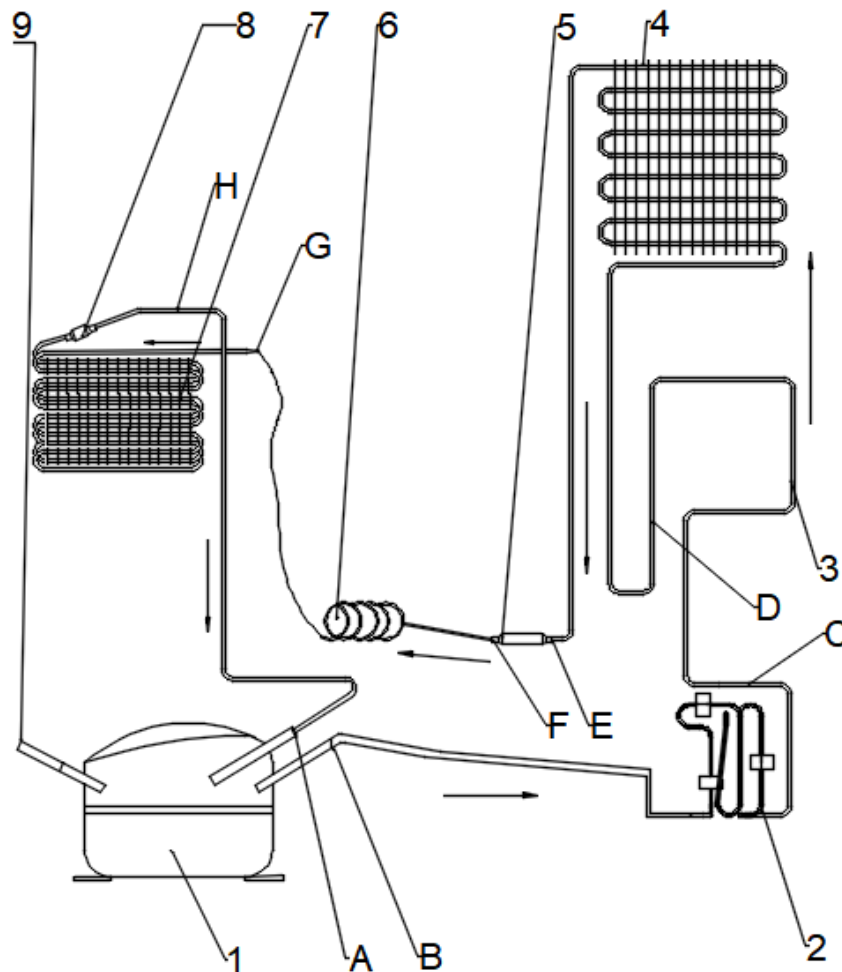

Cooling System Components

- 1- Compressor
- 2- Exhaust evaporation tube
- 3- Freezer Heater pipe
- 4- Condenser
- 5- Drier
- 6- Capillary Tube
- 7- Frz Evaporator
- 8- Reservoir
- 9- Service pipe

Welding Point

- A-Connector pipe / Compressor
- B-Compressor / Exhaust evaporation tube
- C-Exhaust evaporation tube/Heater Pipe
- D-Freezer Heater Pipe / Condenser
- E-Condenser / Drier
- F-Drier / Capillary Tube
- G-Capillary Tube / Frz Evaporator
- H-Frz Evaporator / Suction Pipe

Electrical Components & Specifications

Quantity	Component	Stock Number	Specifications
1	Compressor	1.10.12090E-4XX	VFL090CY1 110V/60Hz R600a UL
2	Freezer Fan Motor	1.33.DTQ431-041	DC12V 2W1600rpm 【TRF-32BINFA】
3	LED Board	1.06.TQ4772-404	LED 【TRF-32BINFHA】
4	Freezer Defrost Heater	1.31.A2941X-341	110V/160W 【TRF-32BINFA】
5	Display Board	1.27.03A2XX-341	UL 12V 【TRF-32BINFA】
6	Control Board	1.27.01A101-435	UL 110V 组件 【TRF-32BINFIA】
7	Door switch	1.11.02341TQ-01	【TRF-32BINFA】
8	damper	1.31.D2840X-341	【TRF-32BINFA】

*Note: For the exact stock number information, look at the BOM List .

Display Panel SetUp Instructions

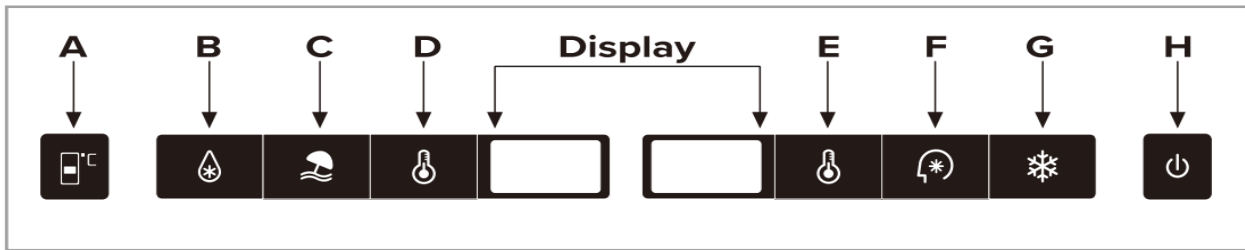

A. Adapt zone temperature adjustment sensor

This button is used to adjust the temperature within the adapt zone. Press this button once to alter the display to show the current temperature in the adapt zone, and then as many times as necessary until the desired level is selected. The settings range from -2°C and 3°C

B. Fast cooling function

Pressing this button will cause the fridge to operate at 2°C and automatically turns off after 2 and a half hours, during this time the button will be illuminated

C. Holiday function

Pressing this button activates the holiday function and the fridge temperature will operate at 17°C and the freezer at -18°C

D. Fridge temperature adjustment

This button is used to adjust the temperature within the fridge. Press this button once to activate adjustment, and then as many times as necessary until the desired level is selected

Display

This is where you can see the current temperature in the fridge (left) and freezer (right)

E. Freezer temperature adjustment

This button is used to adjust the temperature within the freezer. Press this button once to activate adjustment, and then as many times as necessary until the desired level is selected

F. Smart function

This button automatically sets the fridge temperature to 5°C and the freezer temperature to -18°C

G. Fast freezing function

Pressing this button automatically starts the freezer working at a temperature of -25°C . After 6 hours the function stops and the temperature will revert back to its previous setting

H. On/off button

Hold this button down for 3 seconds to switch the appliance on or off

Display Fault Codes

This appliance has 'fault display & alarm' function. Once the sensors got fault, there are alarms displayed on the temperature displaying, the appliance still cools but professional service engineer should be called and check the appliance.

F2 – Sensor of adapt zone

F3 – Sensor of fridge apartment

F4 – Sensor of freezer compartment

F5 – Sensor of defrosting

2E – Fault of fan/motor in freezer

1S – Ice machine malfunction

CE– Communication fault between main panel and display panel.

The above Errors only show on display, no voice

Over temperature alarm in freezer: after freezer temperature arrives at the set temperature, after that, if the temperature rises to $>-1^{\circ}\text{C}$, the alarm will start, accompany with flash of freezer temperature digit. Press any button to cancel the voice alarm. The flash will remain until the temperature is $<-1^{\circ}\text{C}$.

PS: Main board locates in compressor compartment

POSITION	CONDITIONS
5°C/ -18 °C	Summer or ambient temperature between 25-35 °C
5°C/ -18 °C	Spring, autumn or ambient temperature between 15-25 °C
5°C/ -18 °C	Winter, or ambient temperature between 5-15 °C
Super freezing function	Quick freeze
Super cooling function	Super cooling

Instructions for Ice Maker (if applicable)

Key operation instructions.

1. Short press the button, the ice machine state for switching on or off.
2. In the on state, press and hold the button for 10 seconds for manual de-icing.

Lamp status description:

1. Switch on state: the light will fade on and then fade off ---->Breathing state
2. Switch off state: the light is not on.
3. Ice full state: always on
4. Drawer removal: slow flash 0.5 seconds flash once (1HZ)

Fault status.

1. Ice jam:Fast flash 1 time 200ms

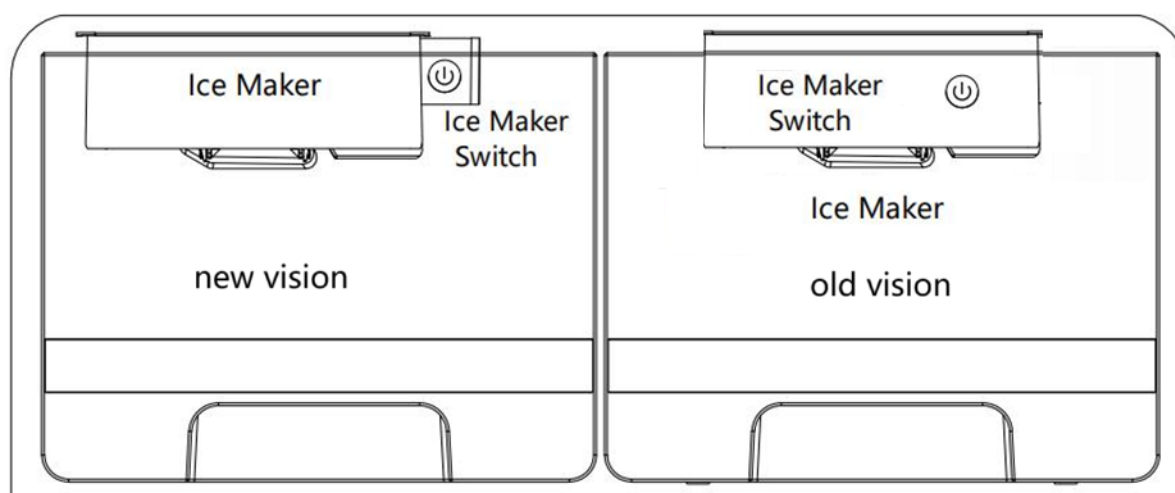

Water connection

Before installing the refrigerator, connect the water pipe in the rear cabin to the water pipe in your home, the cabin is equipped with M11 size connecting water pipe as shown below.

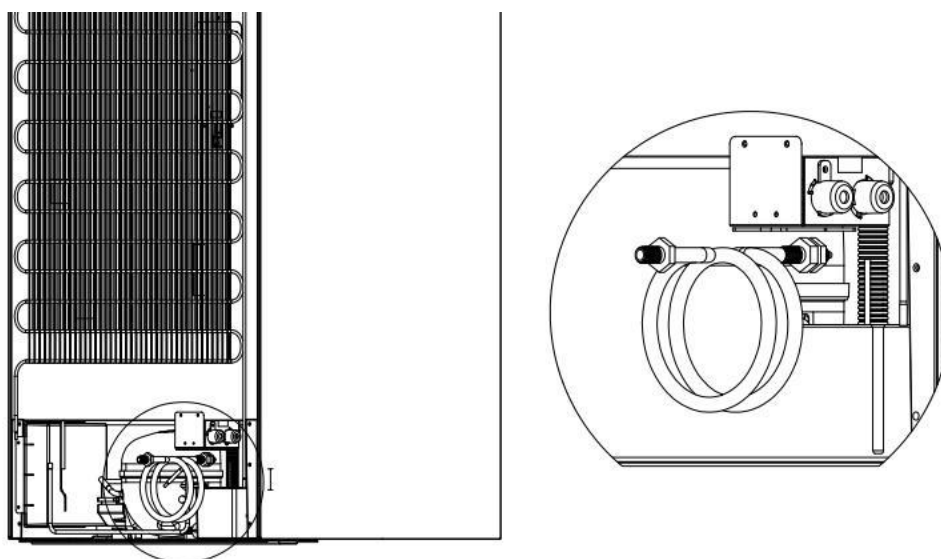

Error Codes

Error Codes	Error Explanation
<u>F1</u>	This item is not available for this model
<u>F2</u>	Chiller Sensor Error
<u>F3</u>	Fridge Sensor Error
<u>F4</u>	Freezer Sensor Error
<u>F5</u>	Defrost Freezer Sensor Error
<u>F6</u>	Ambient Temperature Sensor Error
<u>CE</u>	Communication Failure
<u>2E</u>	Freezer Fan Error
<u>DR</u>	The Refrigerator Opens For More Than 2 Minutes

Knowing the connection numbers on the control board will be necessary for the following error code explanations.

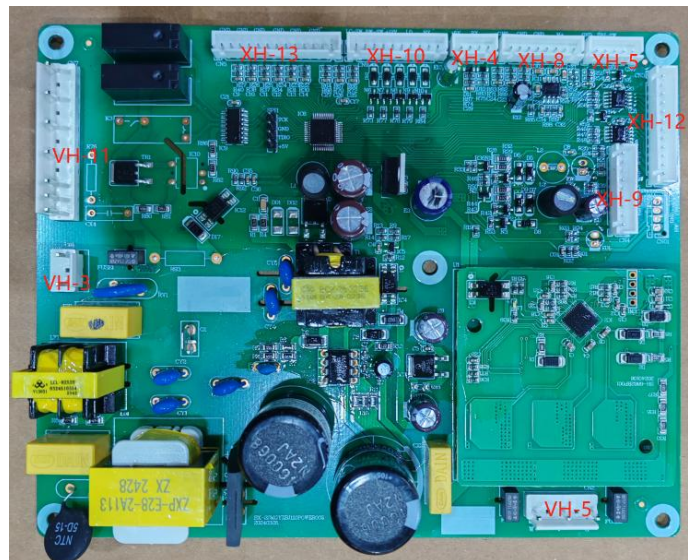

Control Board Connection Numbers	
XH-4	User Interface
XH-10	Lights and Door Switch
XH-8	Ice Maker and Flowmeter
XH-12	Fridge Damper Motor
XH-13	Sensors
XH-5	Ice Maker Switch
VH-3	Power plug input
VH-5	Compressor
VH-11	Freezer Heater

F2 - Chiller Sensor Error

		Yes	No
1	Is F2 flashing?	>>2	Stop
2	Check cables connected to control board sensor socket (XH-13) pins 10 & 11. Is the cable disconnected?	>>3	>>
3	Reconnect the cable and turn the refrigerator back on. Is error still there?	>>4	Solved
4	Remove the harness from the XH-13 socket on the control board. Using a multimeter, measure the sensor pins (10 & 11). Is the resistance reading between 1kΩ and 4kΩ. (2k at 77°F (25°C)) (See chart on page 23)	>>5	>>6
5	Replace the Control Board . (Turn refrigerator back on)	Solved	
6	Replace the faulty Sensor . (Turn refrigerator back on)		

F3 - Fridge Sensor Error

		Yes	No
1	Is F3 flashing?	>>2	Stop
2	Check cables connected to control board sensor socket (XH-13) pins 2 & 3. Is the cable disconnected?	>>3	>>4
3	Reconnect the cable and turn the refrigerator back on. Is error still there?	>>4	Solved
4	Remove the harness from the XH-13 socket on the control board. Using a multimeter, measure the sensor pins (2 & 3). Is the resistance reading between 1kΩ and 4kΩ. (2k at 77°F (25°C)) (See chart on page 23)	>>5	>>6
5	Replace the Control Board . (Turn refrigerator back on)	Solved	
6	Replace the faulty Sensor . (Turn refrigerator back on)	Solved	

F2 Test points



F3 Test points



F4 - Freezer Sensor Error

		Yes	No
1	Is F4 flashing?	>>2	Stop
2	Check cables connected to control board sensor socket (XH-13) pins 6 & 7. Is the cable disconnected?	>>3	>>
3	Reconnect the cable and turn the refrigerator back on. Is error still there?	>>4	Solved
4	Remove the harness from the XH-13 socket on the control board. Using a multimeter, measure the sensor pins (6 & 7). Is the resistance reading between 1kΩ and 4kΩ. (2k at 77°F (25°C)) (See chart on page 23)	>>5	>>6
5	Replace the Control Board . (Turn refrigerator back on)	Solved	
6	Replace the faulty Sensor . (Turn refrigerator back on)		

F5 - Defrost Freezer Sensor Error

		Yes	No
1	Is F5 flashing?	>>2	Stop
2	Check cables connected to control board sensor socket (XH-13) pins 8 & 9. Is the cable disconnected?	>>3	>>4
3	Reconnect the cable and turn the refrigerator back on. Is error still there?	>>4	Solved
4	Remove the harness from the XH-13 socket on the control board. Using a multimeter, measure the sensor pins (8 & 9). Is the resistance reading between 1kΩ and 4kΩ. (2k at 77°F (25°C)) (See chart on page 23)	>>5	>>6
5	Replace the Control Board . (Turn refrigerator back on)	Solved	
6	Replace the faulty Sensor . (Turn refrigerator back on)	Solved	

F4 Test points

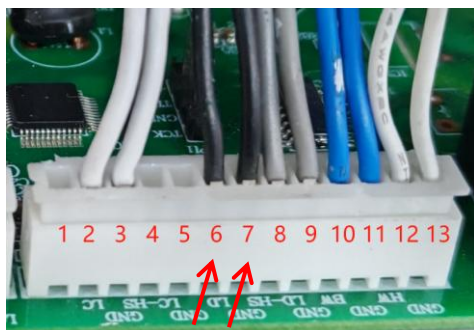

F5 Test points

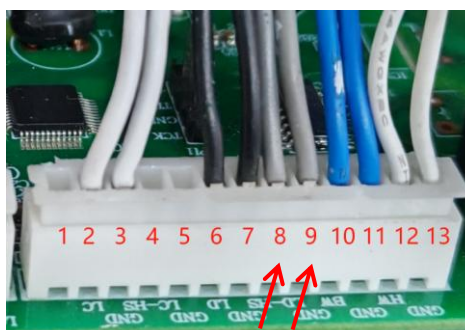

F6 - Ambient Temperature Sensor Error

		Yes	No
1	Is F6 flashing?	>>2	Stop
2	Check cables connected to control board sensor socket (XH-13) pins 12 & 13. Is the cable disconnected?	>>3	>>4
3	Reconnect the cable and turn the refrigerator back on. Is error still there?	>>4	Solved
4	Remove the harness from the XH-13 socket on the control board. Using a multimeter, measure the sensor pins (12 & 13). Is the resistance reading between 1kΩ and 4kΩ. (2k at 77°F (25°C)) (See chart on page 23)	>>5	>>6
5	Replace the Control Board . (Turn refrigerator back on)	Solved	
6	Replace the faulty Sensor . (Turn refrigerator back on)	Solved	

F6 Test points

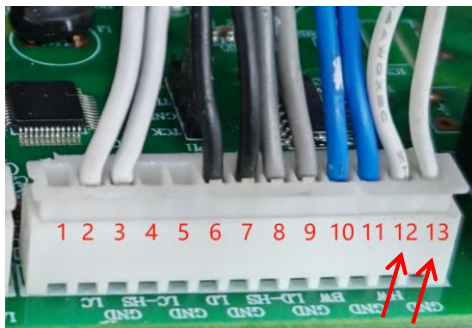

CE - Communication Failure

		Yes	No
1	Is CE flashing?	>>2	Stop
2	Check cables connected to control board socket (XH-4) Is the cable disconnected?	>>3	>>
3	Reconnect the cable and turn the refrigerator back on. Is error still there?	>>4	Solved
4	Check cables connected to User Interface socket Is the cable disconnected?	>>5	>>6
5	Replace the Control Board . (Turn refrigerator back on)	Solved	
6	Replace the User Interface . (Turn refrigerator back on)	Solved	

CE Test points (Control Board)



CE Test points User Interface)



2E- Freezer Fan Error

		Yes	No
1	Is 2E flashing?	>>2	Stop
2	Check cables connected to control board Fan socket (XH-9) pins 3 4& 5. Is the cable disconnected?	>>3	>>4
3	Reconnect the cable and turn the refrigerator back on. Is error still there?	>>4	Solved
4	Using a multimeter, measure the DC voltage between pins Is the resistance reading approximately 12VDC?	>>5	>>6
5	Remove the evaporator cover and ensure nothing is preventing fan blade rotation. Remove blockage. Turn refrigerator back on. Is error still there?	>>6	Solved
6	Replace the Freezer Fan . Turn refrigerator back on. Is error still there?	>>7	Solved
7	Replace control board . Turn refrigerator back on.	Solved	

DR - Door opening alarm Error

		Yes	No
1	Is DR flashing?	>>2	Stop
2	Check whether the refrigeration door is closed tightly, Repeat closing the door, if the fault still exists	>>3	>>4
3	Check whether the induction magnet on the top of the door of the refrigerator is missing. If it is missing, the fault will continue	>>4	Solved
4	Check whether the magnetic switches of the upper beam are normal	>>5	Solved

2E Test points



DR Test points

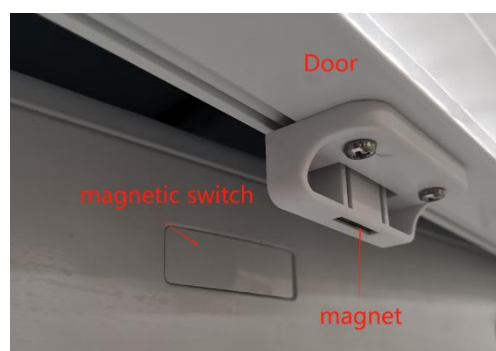

Maintenance guide for refrigeration failure

1. Freezer is not cold enough.
 - Error code on display. First, open and close the freezer door to see if the freezer light is always on. If so, check the freezer drawer brackets.
 - No error code on display. Check if the plugs on the main control board is connected properly.
 - Evacuate the gas and re-gas the system.
2. Freezer does not work
 - If the compressor works, check if the capillary is blocked.
3. Fridge does not work
 - If there is an error code F1, check the fan in fridge. If it is still not working after replacing the fan, check the wiring connection.
 - Check if the reed switch is working properly.
 - Check if the appliance is on a holiday mode.
4. Fresh zone is not working properly
 - Check if the fresh zone is switched off.
 - Check if there is cold air blowing from the outlet, if not, replace the air duct
5. Fridge and freezer are not working
 - Check whether the power cord plug of the main control board is off or not connected.
 - Method 2 Check whether the plugs on the main control board are fully connected or correctly connected.

High Temp Error

When the temperature collected by the freezing sensor reaches set 39°F(+4°C), if the temperature rises $\geq 30^\circ\text{F}(-1^\circ\text{C})$, the high temperature alarm will buzz twice consecutively, and the freezing temperature LED light will flash; Touch any button, the over-temperature alarm sound will be canceled, but the freezing temperature LED light will continue to flash; The alarm will stop only when the temperature collected by the sensor is less than 28°F(-2°C).

If the over-temperature alarm continues after rebooting the appliance, it is necessary to check whether the refrigeration system is blocked, and whether the compressor and fan are working properly.

Temperature to Resistance Chart

Low Range			
Temp	Resistance	Temp	Resistance
-40°F/-40°C	64.06KΩ	-15°F/-26°C	27.07KΩ
-38°F/-39°C	60.10KΩ	-13°F/-25°C	25.52KΩ
-36°F/-38°C	56.41KΩ	-11°F/-24°C	24.06KΩ
-35°F/-37°C	52.96KΩ	-9°F/-23°C	22.70KΩ
-33°F/-36°C	49.74KΩ	-8°F/-22°C	21.42KΩ
-31°F/-35°C	46.73KΩ	-6°F/-21°C	20.22KΩ
-29°F/-34°C	43.92KΩ	-4°F/-20°C	19.10KΩ
-27°F/-33°C	41.29KΩ	-2°F/-19°C	18.04KΩ
-26°F/-32°C	38.83KΩ	-.3°F/-18°C	17.05KΩ
-24°F/-31°C	36.53KΩ	1°F/-17°C	16.11KΩ
-22°F/-30°C	34.38KΩ	3°F/-16°C	15.24KΩ
-20°F/-29°C	32.37KΩ	5°F/-15°C	14.41KΩ
-18°F/-28°C	30.49KΩ	7°F/-14°C	13.64KΩ
-17°F/-27°C	28.72KΩ	9°F/-13°C	12.91KΩ

Normal Operator Range			
Temp	Resistance	Temp	Resistance
10°F/-12°C	12.22KΩ	59°F/15°C	3.13KΩ
12°F/-11°C	11.57KΩ	61°F/16°C	2.99KΩ
14°F/-10°C	10.96KΩ	63°F/17°C	2.85KΩ
16°F/-09°C	10.39KΩ	64°F/18°C	2.73KΩ
18°F/-08°C	9.85KΩ	66°F/19°C	2.60KΩ
19°F/-07°C	9.34KΩ	68°F/20°C	2.49KΩ
21°F/-06°C	8.86KΩ	70°F/21°C	2.38KΩ
23°F/-05°C	8.41KΩ	72°F/22°C	2.28KΩ
25°F/-04°C	7.98KΩ	73°F/23°C	2.18KΩ
27°F/-03°C	7.57KΩ	75°F/24°C	2.08KΩ
28°F/-02°C	7.19KΩ	77°F/25°C	1.99KΩ
30°F/-01°C	6.83KΩ	79°F/26°C	1.91KΩ
32°F/00°C	6.49KΩ	81°F/27°C	1.83KΩ
34°F/01°C	6.17KΩ	82°F/28°C	1.75KΩ
36°F/02°C	5.87KΩ	84°F/29°C	1.68KΩ
37°F/03°C	5.58KΩ	86°F/30°C	1.61KΩ
39°F/04°C	5.31KΩ	88°F/31°C	1.54KΩ
41°F/05°C	5.06KΩ	90°F/32°C	1.48KΩ
43°F/06°C	4.81KΩ	91°F/33°C	1.41KΩ
45°F/07°C	4.58KΩ	93°F/34°C	1.36KΩ
46°F/08°C	4.37KΩ	95°F/35°C	1.30KΩ
48°F/09°C	4.16KΩ	97°F/36°C	1.25KΩ
50°F/10°C	3.96KΩ	99°F/37°C	1.20KΩ
52°F/11°C	3.78KΩ	100°F/38°C	1.15KΩ
54°F/12°C	3.60KΩ	102°F/39°C	1.11KΩ
55°F/13°C	3.44KΩ	104°F/40°C	1.06KΩ
57°F/14°C	3.28KΩ		

Wiring Diagram

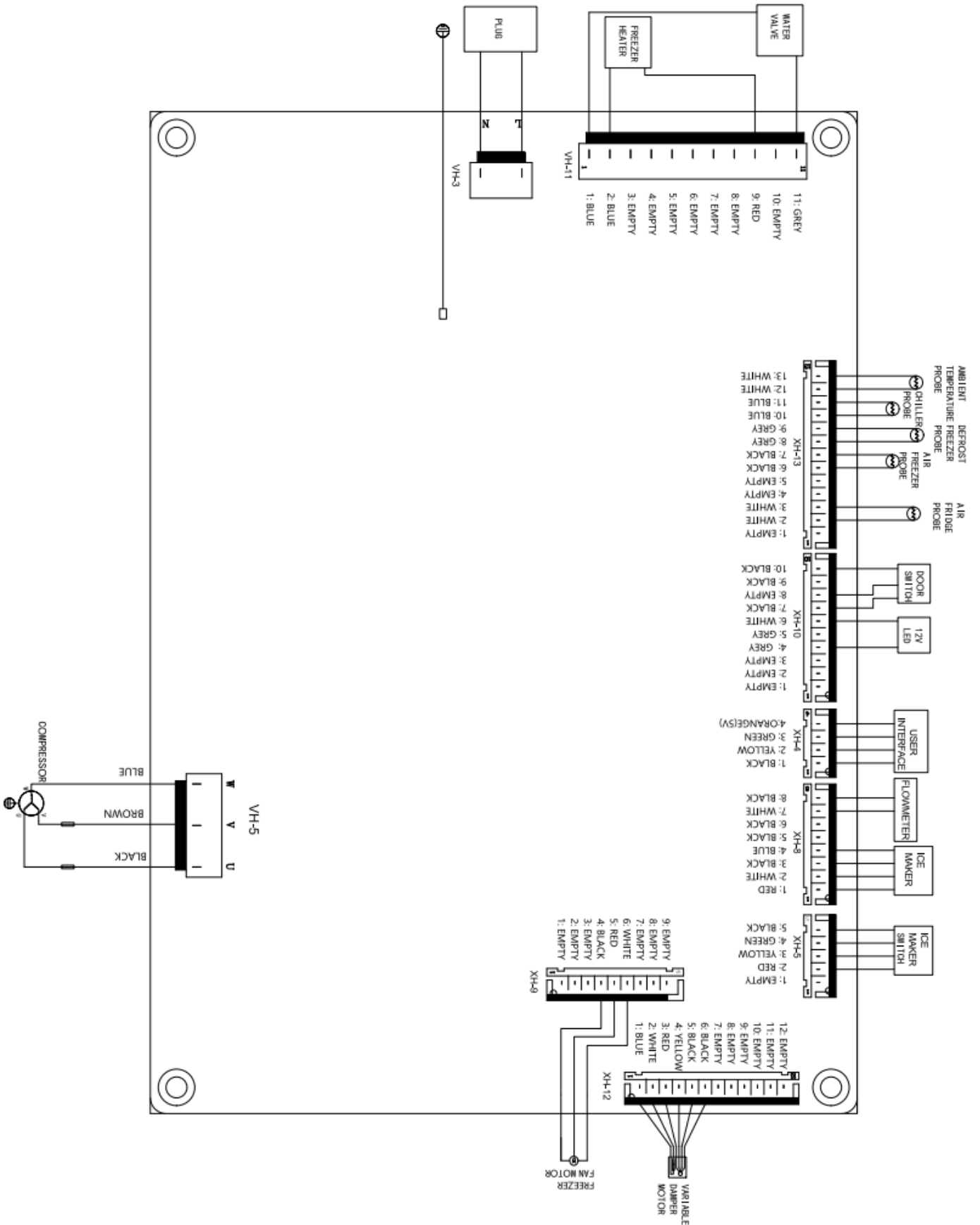

Control Board Test Points (See the picture on page 14 for the control board)

XH-10	Lights and Switch	Contacts	Values
	Light	4&6	12VDC
	Door Switch	7&10	Continuity when Open
XH-4	Display	Contacts	Values
	Display Voltage	3&4	5VDC
XH-8	Ice Maker and Flowmeter	Contacts	Values
	Ice Maker	1-4	12VDC
	Flowmeter	7&8 &10	12VDC
XH-12	Motor	Contacts	Values
	Fridge Damper Motor	1-6	12VDC
XH-9	Fan	Contacts	Values
	Freezer Fan Motor	4&5&6	12VDC
XH-13	Temp Sensors	Contacts	Values
	Air Fridge Probe	2&3	(See chart on page 23)
	Air Freezer Probe	6&7	
	Defrost Freezer Probe	8&9	
	Chiller Probe	10&11	
	Ambient Temperature Sensor	12&13	
XH-5	Ice Maker Switch	Contacts	Values
	Ice Maker Switch	2-5	12VDC
VH-3	Plug	Contacts	Values
	Plug	1&3	110VAC
VH-5	Compressor	Contacts	Values
	Compressor	1&3&5	110VAC
VH-11	Heater and Water Valve	Contacts	Values
	Freezer Heater	2&9	110VAC
	Water Valve	1&11	110VAC

Main control board led flashing fault

Compressor does not start - list of fault codes prompted by main control panel indicator				
Serial number	Flashing times of main control panel LED	Main control board fault	Cause analysis of compressor failure	terms of settlement
1	LED flashes once	Overvoltage	1. The input voltage is too high, and the input voltage of 110V model is higher than 110V (this situation will cause the control board to burn out, the machine will not work, and there is no response) 2. Abnormal control board	1. Check whether the power supply voltage is normal 2. Disconnect the power and restart the machine 3. Replace the control board
2	LED flashes twice	Undervoltage	1. The input voltage is low, and the input voltage of 220V model is lower than 110V 2. Abnormal control board	1. Check whether the power supply voltage is normal 2. Disconnect the power and restart the machine 3. Replace the control board
3	LED flashes 3 times	communication	1. Abnormal data transmission between main board and frequency conversion board	1. Disconnect the power and restart the machine 2. Replace the control board
4	LED flashes 4 times	Phase deficiency	1. The compressor harness is not connected properly 2. The fuse on the compressor line is burnt out 3. The compressor is broken	1. Check the compressor line sequence 2. Check whether the fuse is burnt 3. Replace the compressor if there is no problem above
5	LED flashes 7 times	Software overcurrent	1. The actual current reaches the current threshold set by the software (the protection threshold setting is too small) 2. The software has a bug and does not meet the protection status required by special requirements	1. Disconnect the power and restart the machine 2. Replace the control board
6	LED flashes 10 times	Start failure, small board current detection circuit failure	1. The control board is broken 2. The solenoid valve is broken, resulting in excessive system pressure 3. The compressor is broken and the cylinder is jammed	1. Disconnect the power and restart the machine 2. Replace the control board 3. Replace the solenoid valve 4. Replace the compressor
7	LED flashes 12 times	Hardware overcurrent	1. The current detection is too large due to hardware components 2. Special abnormality causes damage to the components of the frequency conversion board, resulting in abnormality of the frequency conversion board	1. Replace the control board
8	LED flashes 14 times	Stall	1. Compressor internal jamming 2. The compressor is unstable 3. Wrong line sequence	1. Check whether the wire sequence UVW is connected properly 2. Check whether the compressor is aligned 3. Replace the compressor

Note: If the number 5, 6, 7 and 8 are abnormal, the theoretical priority is 6; No. 6 Normally, No. 8 appears first, followed by No. 5, and finally No. 7

The above phenomena are detected by current, Therefore, there are many factors that cause the current change:

1. The system pressure is abnormal
2. The solenoid valve is not conductive
3. The control board hardware is abnormal.
4. Ice jam.
5. The threshold set by the software is not large enough

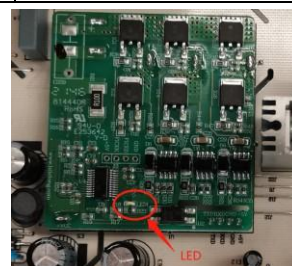

Component Access and Removal



Disassembly should only be done with the product unplugged and by an authorized technician.

Control Board



1. Remove the mounting box on the left side of the press bin
2. Remove the clip and take out the main control board

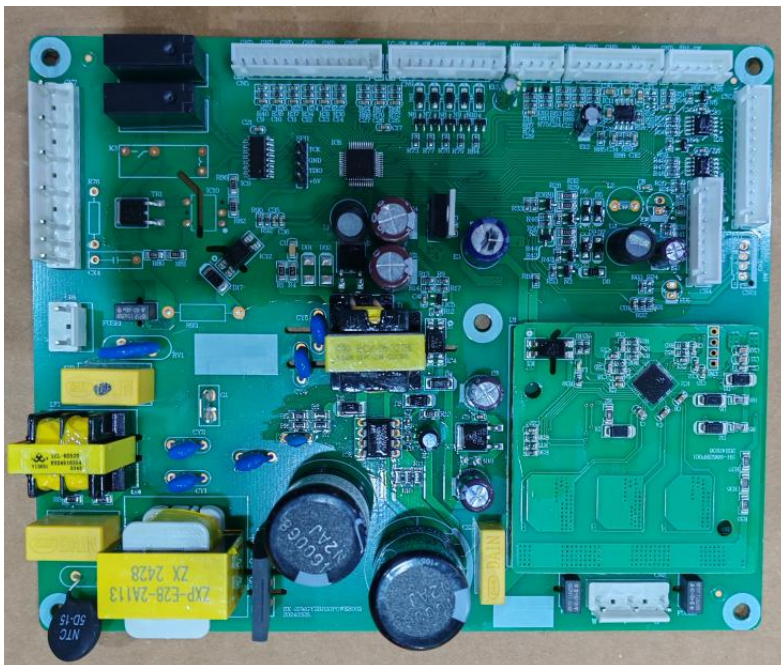

Display



1. Remove the left trim cover
2. Remove the display board mounting box

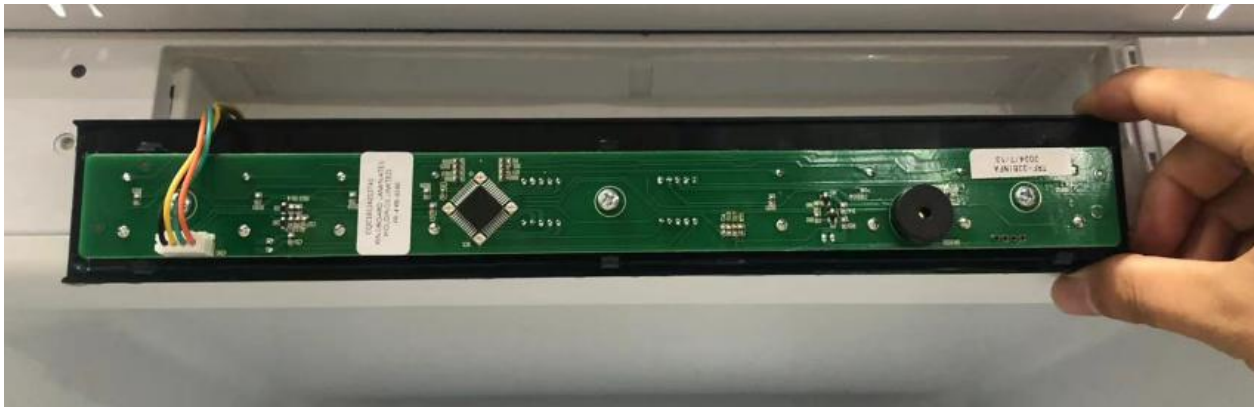

Ice Maker



1. Pull out the freezer drawer
2. Remove the 3 screws holding the ice maker in place to remove the ice maker

Temperature inside the box Sensor



1. Remove the air duct cover to take out the internal sensor



Refrigerator magnetic light switch



1. Remove the door switch mounting cover located in the center sill.
Take out the magnetic control switch

Refrigerator room Overhead light

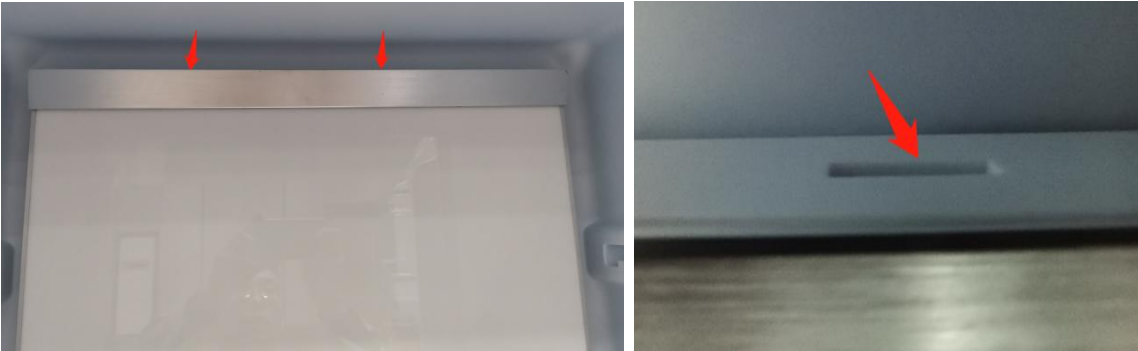

1.Remove the top metal strip and take it out from the clip at the back of the top



2.Remove the two left and right fixing screws and pull off the plug



Refrigerator rail removal



1. Pull out the fruit and vegetable box and take it up

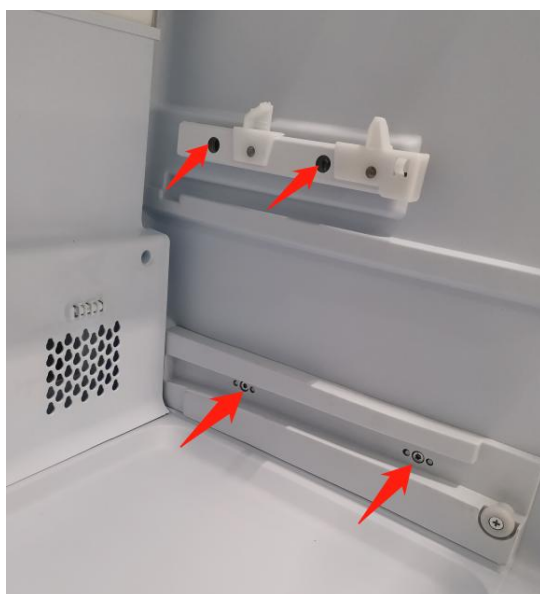

2. Retract the slide rail and remove it with a Torx T20 screwdriver

Refrigerator the Rear Wall



1. Remove the rear cover as shown and unplug the cable

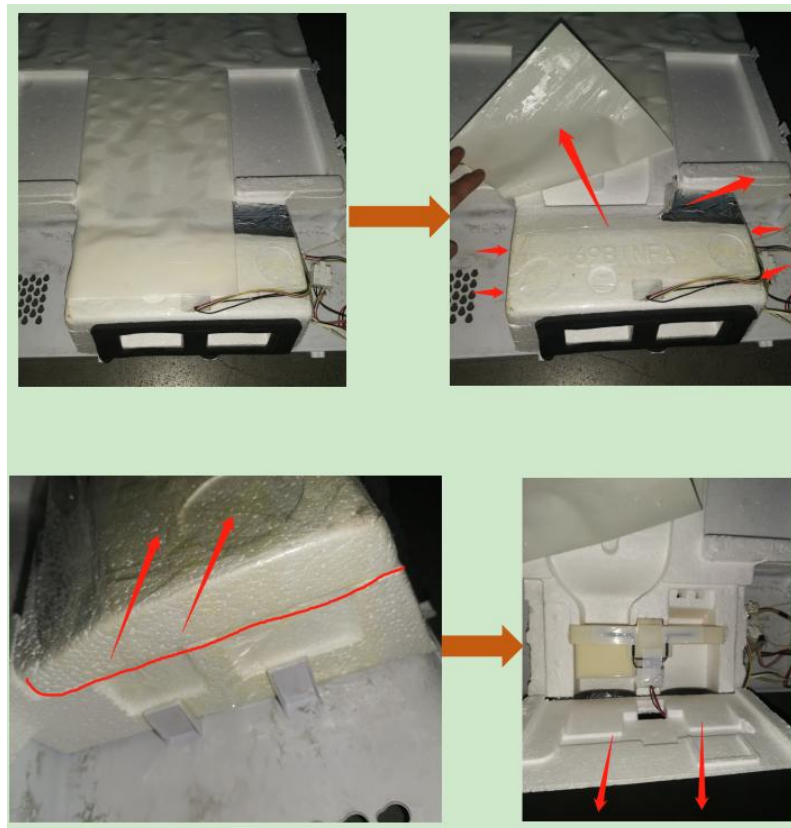

2. Remove the sealing cotton according to the steps shown in the figure and remove the electric damper

Freezer the Rear Wall



- 1.Remove the rear cover as shown and unplug the cable
- 2.Uncover the isolation sponge



- 3.Remove the fixing screws and separate the front and rear covers of the cover plate
- 4.Remove the fan

Defrost Element & Thermal Fuse+

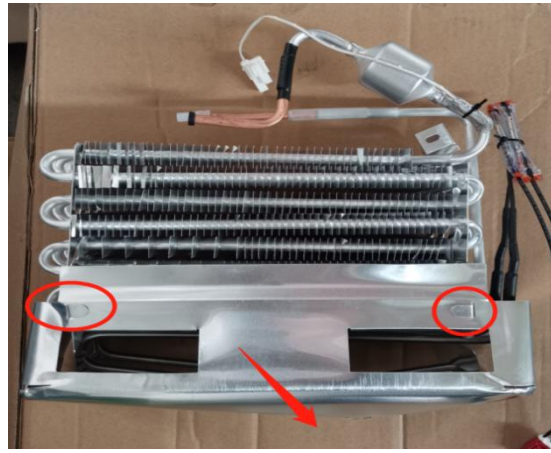
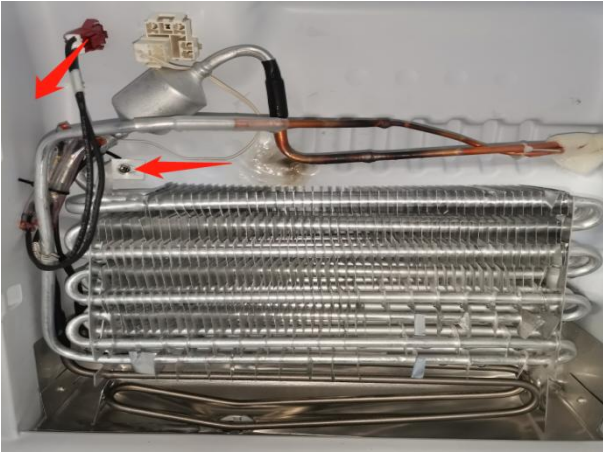

1. Remove the fixing screws
2. Remove the water drip pan at the back

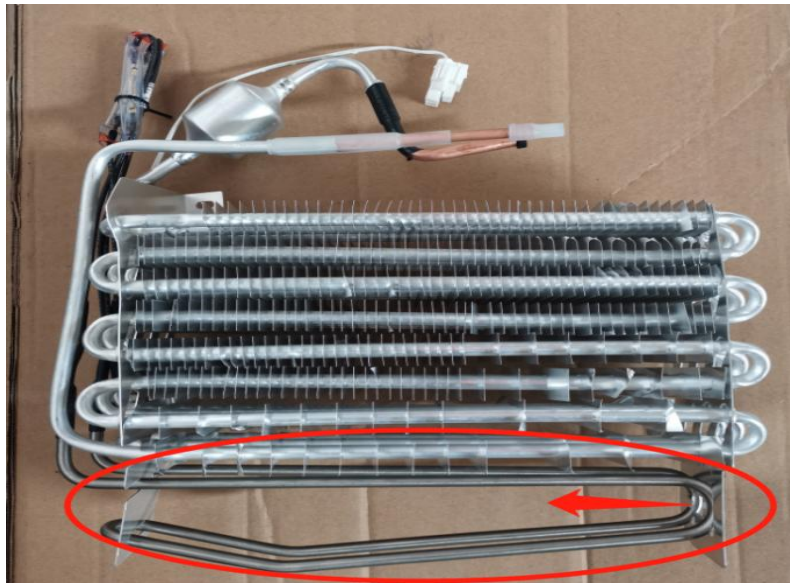

3. Remove the heater

Troubleshooting

Symptom	Possible Cause	Corrective Action
The Freezer compartment is too cold, but the refrigerator temperature is fine.	The Freezer compartment temperature is set too low.	Set Freezer temperature to a higher setting.
The Fresh Food compartment is too cold, but the Freezer temperature is fine.	The Fresh Food temperature is set too low.	Set Fresh Food temperature to a higher setting.
	Door not sealing	Check door gaskets.
	Fan not running	Check fan.
The refrigerator's operating sounds varies over time.	The operating sounds will vary according to different cycles, food volume and environmental conditions.	This is normal.
The refrigerator makes vibration or other strange noises.	Various components make vibration sounds, such as when water valves energize. Also gas flowing through refrigerant lines can make gurgling noises. And popping and sizzling sounds can occur during the defrost cycle.	As long as both compartments are maintaining proper temperatures, these sounds are normal.
Evaporator Fan is noisy.	The fan blade may be irregular.	Remove evaporator cover and inspect fan for irregularities. Replace if necessary.
	Fan blade may be hitting something.	Remove evaporator cover and inspect fan area for any obstructions. Adjust fan or remove obstructions.
	Fan speed may be too high.	Check fan speed for proper RPMs. Fan may be noisy if RPMs are too high. Replace fan motor, if so.

Troubleshooting (Continued)

Symptom	Possible Cause	Corrective Action
Condensation develops on outside of refrigerator, or between doors.	Excessive ambient heat or humidity can cause moisture to develop on cooler surfaces.	It is normal during hot or humid seasons to see increased condensation on the outside of the unit. This will decrease as ambient humidity goes away.
Refrigerator doors will not close.	Something may be blocking the door.	Check food placement and adjust if necessary.
	The door gasket may not be seating properly	Inspect gasket. Adjust or replace.
The doors squeak when opening or closing.	Door hinges are worn.	Replace door hinges.