

Dual-flush Toilet

Inodoro de doble descarga

Toilettes à double chasse d'eau

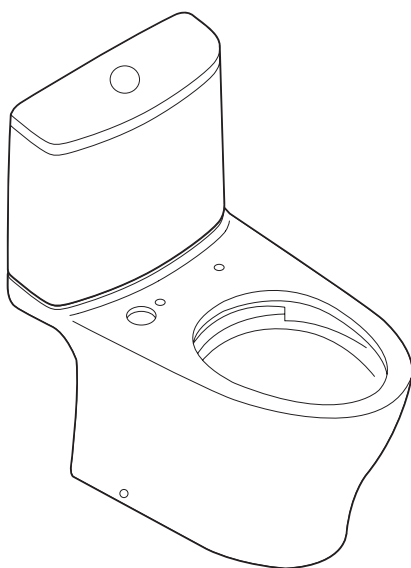

CST446

Warranty Registration and Inquiry

For product warranty registration, TOTO U.S.A. Inc. recommends online warranty registration. Please visit our web site <http://www.totousa.com>. If you have questions regarding warranty policy or coverage, please contact TOTO U.S.A. Inc., Customer Service Department, 1155 Southern Road, Morrow, GA 30260 (888) 295-8134 or (678) 466-1300 when calling from outside of U.S.A.

TABLE OF CONTENTS

Thanks for Choosing TOTO!	2
Included Parts	2
Common Tools Needed.....	2
Before Installation.....	3
Installation Procedure.....	4
Care and Cleaning.....	7
Replacing the Fill Valve	8
Adjusting the Water Level.....	8
Servicing Fill Valve	9
Servicing Flush Valve	10
CEFIONTECT® Cleaning Instructions	10
Warranty.....	11

THANKS FOR CHOOSING TOTO!

The mission of TOTO is to provide the world with healthy, hygienic and more comfortable lifestyles. We design every product with the balance of form and function as a guiding principle. Congratulations on your choice.

INCLUDED PARTS

Check to make sure you have the following parts included in your package*:

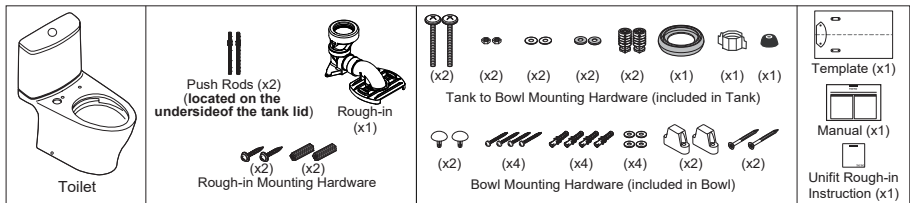

* Actual parts may appear different from drawing according to the model.

COMMON TOOLS NEEDED

- | | |
|---|---|
| <ul style="list-style-type: none"> ■ 10" adjustable wrench ■ Carpenters' level ■ Hacksaw ■ Tape measure ■ Hand pliers ■ Flat head screwdriver ■ Phillips screwdriver | <ul style="list-style-type: none"> ■ Pencil ■ Putty knife ■ Drill ■ Drill bits (mounting block)
 For wood floor installation:
 - 1/8" drill bit
 For concrete/tile installation:
 - 5/16" drill bit |
|---|---|

MATERIALS REQUIRED:

(Not Included)

- Flexible supply hose
- Angle stop valve
- Wax ring

BEFORE INSTALLATION

- Read these instructions thoroughly before beginning work.
- Please leave instructions for customers. These instructions contain maintenance and warranty information.
- If necessary, remove the existing toilet and if new construction, purge the supply line.

NOTICE

Due to the powerful performance of our Tornado, G-Max, E-Max and Power Gravity flushing systems, they are not specified for back-to-back installations. The only means of installing these toilets in a back-to-back situation is when the toilet drain connections incorporate a WYE fitting. Please contact your builder or contractor prior to this installation.

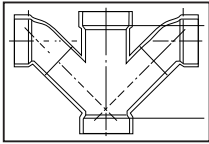

Double Combination WYE / 1/8 Bend
YES

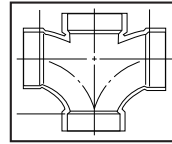

Double Sanitary Tee / Sanitary Cross
NO

Water supply shut-off valve installation recommendations

Follow these recommendations to ensure an optimal and trouble-free installation with a neat and professional appearance.

Location (From floor and left of center of floor flange)	4-3/4" x 5-7/8" (120mm x 150mm)
Valve type	Angle stop type valve with supply connection facing upward, inward, or downward NOTE: Straight stop type valve, or valve with supply connection on front of angle stop, is not recommended
Maximum length	Angle stop must protrude less than 3" (80mm) from wall

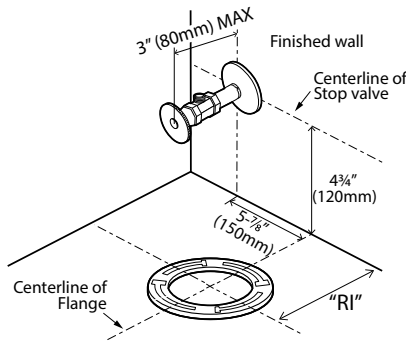

INSTALLATION PROCEDURE

1. Open the Unifit Rough-In packaging. Follow the Unifit Rough-In Installation instruction to complete the rough-in installation (ill. 1).
2. Place the template into position and follow its instructions to prepare for installing the toilet bowl.

NOTICE Do not move the Unifit Rough-In on the Floor Flange after wax seal is set. If this notice is disregarded, discard the wax ring and replace with new wax ring.

3. Place the toilet bowl over the Unifit Rough-In and the two mounting blocks, by aligning the bowl outlet with the Unifit Rough-In opening (ill. 2).

NOTICE Insert the toilet all the way into position. If this notice is disregarded, leakage may result.

NOTICE Check for rocking. If needed, use shims to prevent the toilet from rocking.

4. Align the toilet perpendicular to the back wall and parallel to side walls; it should not sit crooked or diagonal (ill. 3).

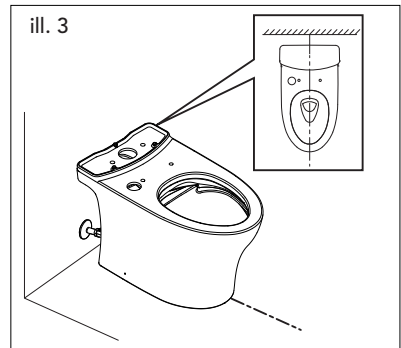
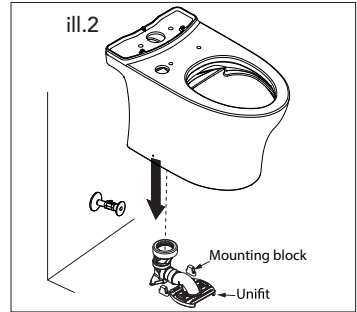
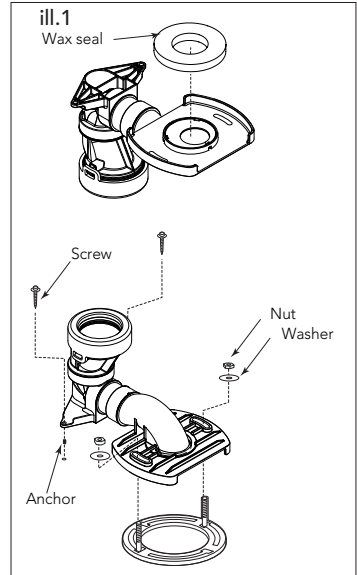

INSTALLATION PROCEDURE

5. Install the side screws to the mounting blocks. Cover the screw head with the provided screw caps (ill. 4).

6. Install the tank-to-bowl mounting hardware to the tank (ill. 5).

CAUTION Do NOT overtighten hardware, as it may break the china and cause personal injury or property damage.

7. Place the tank upside down onto some padding. Inspect the smaller fill valve nut and larger flush valve nut for a secure connection (ill. 6). Try to tighten the nuts with your hands. If loose, tighten the nut hand tight and an additional 1/4 turn for the smaller fill valve nut and an additional 1/2 turn for the larger flush tower nut.

NOTICE Make sure that the fill valve does not turn and hit the tank while tightening.

8. Connect the water supply hose (not provided) to the fill valve (ill. 5).

NOTICE The water supply hose must be connected to the fill valve BEFORE the tank-to-bowl installation. TOTO recommends using a longer flexible supply hose.

9. Place the tank-to-bowl gasket onto the flush tower nut (ill. 7). While pressing down, spread the gasket over the nut until the gasket touches the bottom of the tank. A slight gap between the tank bottom and the gasket is allowable.

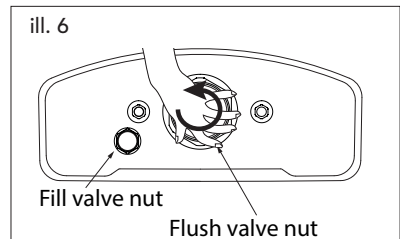
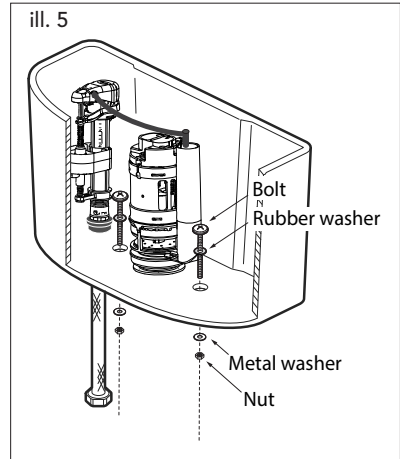
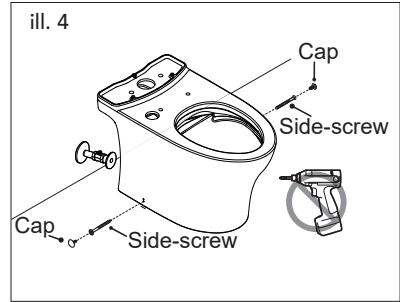

INSTALLATION PROCEDURE

- Pick up the tank and carefully guide the water supply hose over the bowl's fill valve hole, align the tank-to-bowl gasket over the inlet of the bowl, and align the tank bolts over the bolt holes of the bowl.
- Using provided tank-tight nuts, hand tighten the nuts evenly until tank sets snugly on each of the 3 contact points on the bowl (ill. 8).

CAUTION Do not overtighten the mounting bolts. Overtightening may break the china and cause personal injury and/or property damage.

- Install the flexible water supply hose to the angle stop (ill. 9). Make sure that the hose is free of kinks.

ill. 7

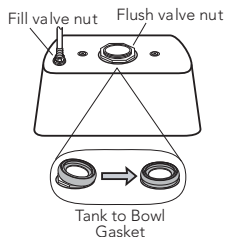

ill. 8

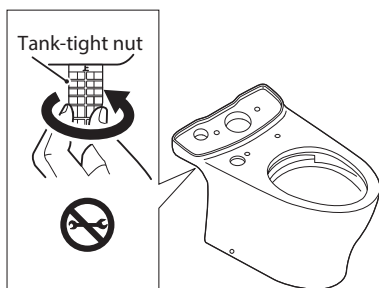
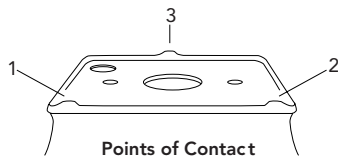

ill. 9

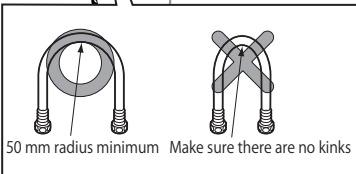
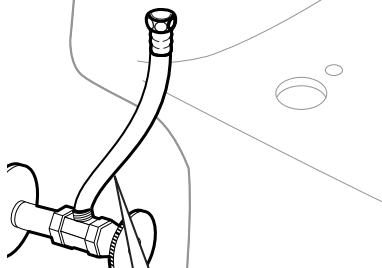

INSTALLATION PROCEDURE

13. On the underside of the tank lid, remove the 2 rods with lock nuts, and screw them clockwise to the push button assembly.

Place the lid on top of the tank, making sure that the full flush push button is on the left side (ill 10).

14. Adjust the length of the rods. If the push button rods are too short (see ill. 11a), the push buttons will not sit properly and toilet may short flush. If the push button rods are too long (see ill. 11b), the push button may continuously activate the flush valve.

Correct with the following steps:

1. Loosen the lock nuts counter-clockwise.
 2. Turn the rods clockwise to shorten, counter-clockwise to lengthen (each full turn is 1mm).
 3. Place the lid on the tank to check the adjustment.
 4. When the adjustment is completed, tighten the lock nut to secure.
15. Turn on the water supply at the angle stop. Check ALL connections for leaks. Fix as needed.
16. The toilet seat is installed with the seat top mounting hardware. Refer to the seat installation instruction.

ill. 10

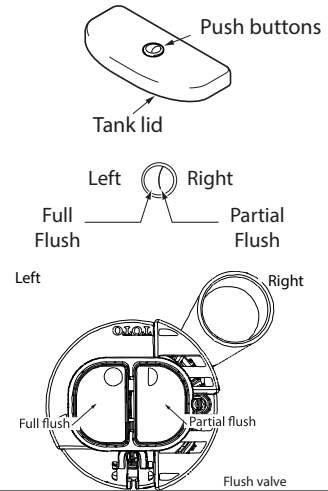

ill. 11a

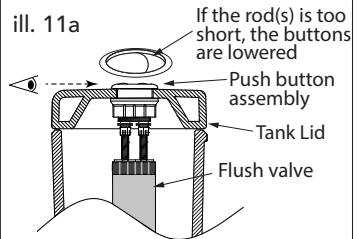

ill. 11b

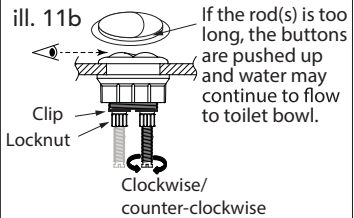

CARE AND CLEANING

Use a detergent or non-abrasive toilet cleaner and a soft bristled plastic brush to clean your toilet. To remove hard water stains, use vinegar or lime dissolving cleaner and a non-scratch scour pad made for porcelain. Allow a little contact time to allow the cleaner to dissolve the buildup.

NOTICE

DO NOT USE IN-TANK BOWL CLEANERS.

The use of high concentration of chlorine or chlorine-related products can seriously damage fittings in the tank. This damage can cause leakage and property damage. TOTO shall not be responsible or liable for any tank fitting failure or damage caused by the use of in-tank bowl cleaners.

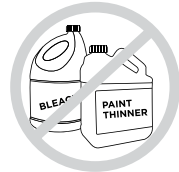

REPLACING THE FILL VALVE

1. Shut off the water supply. Flush the toilet and remove any remaining water from the tank. Reverse the tank installation instructions to remove it from the bowl. Remove the old fill valve.
2. Install new fill valve by sliding the threaded portion of the shaft through the hole in the bottom of tank.
3. Thread mounting nut onto exposed shaft under the tank and tighten nut.

ill. 1

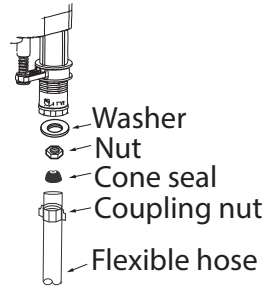

CAUTION Do not over-tighten.

4. Connect the water supply (see ill. 1). Pipe dope is not recommended. Attach the refill tube to the valve and clip the other end to the overflow pipe.

ADJUSTING THE WATER LEVEL

Refer to the water level line stamp inside the tank.

1. The water level adjustment is located in the top end of the fill valve. Use a flathead screwdriver to make adjustments:
 - To raise the water level: turn the screwdriver clockwise, or towards the '+' indicator.
 - To lower the water level: turn the screwdriver counter-clockwise, or towards the '-' indicator.
2. Flush after each adjustment to check the water level. When satisfied with the water level, flush once more to verify.

ill. 1

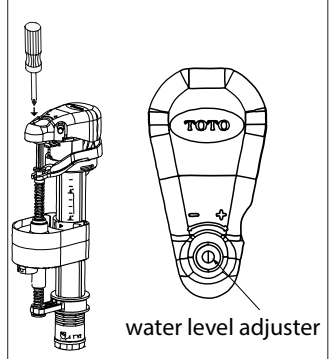

SERVICING THE FILL VALVE

NOTE: Due to water conditions in your area, the strainer may require periodic cleaning. An indication that the strainer requires service can be seen in a delayed fill cycle, intermittent fill cycle, or inadequate amount of water flow from the refill tube.

1. Snap off the top cover by pulling from under the tab (see ill. 1).
2. Pinch the tabs of the lever arm to allow its removal (see ill. 2).
3. Snap off the adjustable rod from the bracket **(1)** allowing the unit to slide to the bottom and remove the retainer tab by pulling as the arrow indicates **(3)** (see ill. 3).
4. Grab hold of the valve unit, twist 1/4 turn counterclockwise and pull the unit out (see ill. 4).
5. Unscrew nut of the diaphragm housing (see ill. 5).
6. Remove the diaphragm from its housing by carefully pulling the edge of the diaphragm (see ill. 6). Note the position of the diaphragm while removing.
7. Remove the strainer from the tube with needle nose pliers (see ill. 7). Use twisting motion while pulling to help with removal.
8. Rinse all parts under running water to clear any debris, residues or films. Reinstall all parts in reverse order. Turn the water ON and check for leaks and operation.

ill. 1

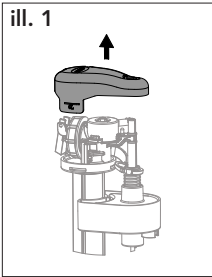

ill. 2

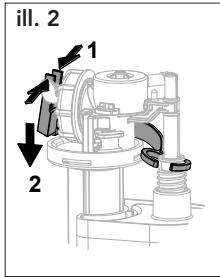

ill. 3

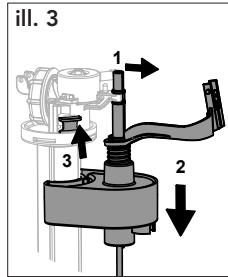

ill. 4

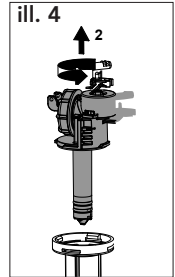

ill. 5

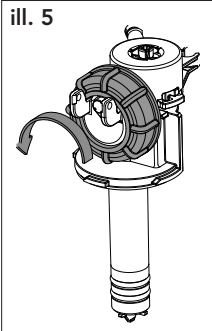

ill. 6

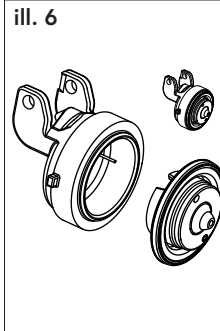

ill. 7

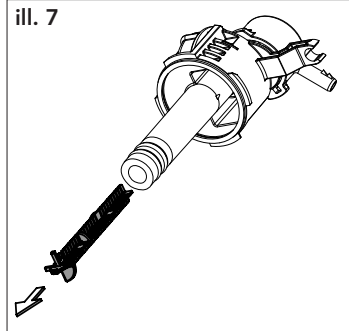

SERVICING THE FLUSH VALVE

1. Turn off water supply and flush the toilet.
2. Remove the tank lid and place it upside down on a clean surface.
3. Note the orientation of the flush valve for reassembly.
4. Turn the upper half of flush valve counter-clockwise and pull it up to remove it (see ill. 1).
5. Remove the rubber seal gasket and rinse under running water to clean (see ill. 2).
6. Place the gasket back on the flush valve (see ill. 3).
7. Install the flush valve back on the base.
8. Rotate the flush valve so that the partial flush button is on the right and the full flush button is on the left.
9. Carefully, install the tank lid back on the tank.
10. Flush the toilet several times using each push button to verify proper operation. Check for leakage.

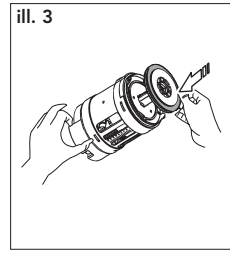
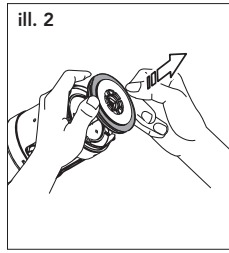
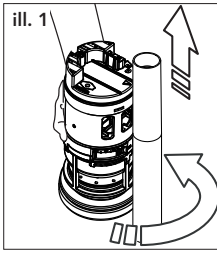

CEFIONTECT® CLEANING INSTRUCTIONS



WHAT IS CEFIONTECT®?

CEFIONTECT® is TOTO's super-smooth permanent glaze that prevents debris from sticking to surfaces. Products with the letter "G" in the number have the CEFIONTECT® glaze. This glaze, along with regular cleaning, will help keep your TOTO product in pristine condition.



No CEFIONTECT®

NOTE:

For best results to keep your TOTO product with CEFIONTECT® clean:

- Lavatory: Use a mild dish detergent with a clean, soft cloth.
- Toilet: Use a gel based cleaner with a soft bristled-plastic brush.
- **Don't use** cleaners, polishing powders or detergents that have gritty or coarse particles.
- **Don't use** bleach, chemical thinners or products that have acid or alkaline detergents listed as ingredients.
- **Don't use** metal scrub brushes or steel wool.



With CEFIONTECT®



Following these instructions will ensure that your TOTO product with the CEFIONTECT® glaze will always stay intact, keeping your product like new for years to come!

WARRANTY

1. TOTO warrants its vitreous china products ("Product") to be free from defects in materials and workmanship during normal use when properly installed and serviced, for a period of one (1) year from date of purchase. This limited warranty is extended only to the ORIGINAL PURCHASER of the Product and is not transferable to any third party, including but not limited to any subsequent purchaser or owner of the Product. This warranty applies only to TOTO Product purchased and installed in North, Central and South America.
2. TOTO's obligations under this warranty are limited to repair, replacement or other appropriate adjustment, at TOTO's option, of the Product or parts found to be defective in normal use, provided that such Product was properly installed, used and serviced in accordance with instructions. TOTO reserves the right to make such inspections as may be necessary in order to determine the cause of the defect. TOTO will not charge for labor or parts in connection with warranty repairs or replacements. TOTO is not responsible for the cost of removal, return and/or reinstallation of the Product.
3. This warranty does not apply to the following items:
 - a. Damage or loss sustained in a natural calamity such as fire, earthquake, flood, thunder, electrical storm, etc.
 - b. Damage or loss resulting from any accident, unreasonable use, misuse, abuse, negligence, or improper care, cleaning, or maintenance of the Product.
 - c. Damage or loss resulting from sediments or foreign matter contained in a water system.
 - d. Damage or loss resulting from improper installation or from installation of the Product in a harsh and/or hazardous environment, or improper removal, repair or modification of the Product. (NOTE: Product model codes allow a maximum of 80 PSI. Check local codes or standards for requirements).
 - e. Damage or loss resulting from electrical surges or lightning strikes or other acts which are not the fault of TOTO or which the Product is not specified to tolerate.
 - f. Damage or loss resulting from normal and customary wear and tear, such as gloss reduction, scratching or fading over time due to use, cleaning practices or water or atmospheric conditions.
 - g. Tank flushing mechanisms of plastic or rubber moving parts.
 - h. Toilet seats of plastic, wood or metal.
4. In order for this limited warranty to be valid, proof of purchase is required. TOTO encourages warranty registration upon purchase to create a record of Product ownership at <http://www.totousa.com>. Product registration is completely voluntary and failure to register will not diminish your limited warranty rights.
5. THIS WARRANTY GIVES YOU SPECIFIC LEGAL RIGHTS. YOU MAY HAVE OTHER RIGHTS WHICH VARY FROM STATE TO STATE, PROVINCE TO PROVINCE OR COUNTRY TO COUNTRY.
6. To obtain warranty repair service under this warranty, you must take the Product or deliver it prepaid to a TOTO service facility together with proof of purchase (original sales receipt) and a letter stating the problem, or contact a TOTO distributor or products service contractor, or write directly to TOTO U.S.A., INC., 1155 Southern Road, Morrow, GA 30260 (678) 466-1300 or (888) 295-8134, if outside the U.S.A. If, because of the size of the Product or nature of the defect, the Product cannot be returned to TOTO, receipt by TOTO of written notice of the defect together with proof of purchase (original sales receipt) shall constitute delivery. In such case, TOTO may choose to repair the Product at the purchaser's location or pay to transport the Product to a service facility.

THIS WRITTEN WARRANTY IS THE ONLY WARRANTY MADE BY TOTO. REPAIR, REPLACEMENT OR OTHER APPROPRIATE ADJUSTMENT AS PROVIDED UNDER THIS WARRANTY SHALL BE THE EXCLUSIVE REMEDY AVAILABLE TO THE ORIGINAL PURCHASER. TOTO SHALL NOT BE RESPONSIBLE FOR LOSS OF THE PRODUCT OR FOR OTHER INCIDENTAL, SPECIAL OR CONSEQUENTIAL DAMAGES OR EXPENSES INCURRED BY THE ORIGINAL PURCHASER, OR FOR LABOR OR OTHER COSTS DUE TO INSTALLATION OR REMOVAL, OR COSTS OF REPAIRS BY OTHERS, OR FOR ANY OTHER EXPENSE NOT SPECIFICALLY STATED ABOVE. IN NO EVENT WILL TOTO'S RESPONSIBILITY EXCEED THE PURCHASE PRICE OF THE PRODUCT. EXCEPT TO THE EXTENT PROHIBITED BY APPLICABLE LAW, ANY IMPLIED WARRANTIES, INCLUDING THAT OF MERCHANTABILITY OR FITNESS FOR USE OR FOR A PARTICULAR PURPOSE, ARE EXPRESSLY DISCLAIMED. SOME STATES DO NOT ALLOW LIMITATIONS ON HOW LONG AN IMPLIED WARRANTY LASTS, OR THE EXCLUSION OR LIMITATION OF INCIDENTAL OR CONSEQUENTIAL DAMAGES, SO THE ABOVE LIMITATION AND EXCLUSION MAY NOT APPLY TO YOU.

WARNING! TOTO shall not be responsible or liable for any failure of, or damage to, this Product caused by either chloramines in the treatment of public water supply or cleaners containing chlorine (calcium hypochlorite). NOTE: The use of a high concentrate chlorine or chlorine related products can seriously damage the fittings. This damage can cause leakage and serious property damage. For more information, please call TOTO at (888) 295-8134.

TOTO

TOTO U.S.A., Inc. 1155 Southern Road,
Morrow, Georgia 30260

Tel: 888-295-8134 Fax: 800-699-4889

www.totousa.com

0GU179-4

Rev Date: 6/22



Warranty Registration and Inquiry

For product warranty registration, TOTO U.S.A. Inc. recommends online warranty registration. Please visit our web site <http://www.totousa.com>. If you have questions regarding warranty policy or coverage, please contact TOTO U.S.A. Inc., Customer Service Department, 1155 Southern Road, Morrow, GA 30260 (888) 295-8134 or (678) 466-1300 when calling from outside of U.S.A.