

Item Number:

A-Frame Camper Charcoal Grill : STARBBQ-AFCG

**Read all instructions before you operate your appliance.
Save these instructions!**

To installer or person assembling appliance: Leave this manual with appliance for future reference.
To consumer: Keep this manual for future reference.

www.SunstoneMP.com

Welcome & Congratulations

Congratulations on your purchase of the **STARBBQ-AFCG Folding A-Frame Camper Charcoal Grill by Sunstone Metal Products!** We are proud of this premium portable grill and are committed to providing you with the best ownership experience possible. Your complete satisfaction is our #1 priority.

Please take a few minutes to read this manual carefully. It contains all the information you need to safely set up, operate, and maintain your STARBBQ-AFCG for years of reliable performance, efficient charcoal grilling, and memorable outdoor adventures—whether camping, tailgating, at the beach, or in your backyard.

We know you're going to love grilling with family and friends around your new portable STARBBQ-AFCG, and we sincerely thank you for choosing Sunstone Metal Products. We hope you'll consider us for all your future outdoor living needs.

Before you call: If your grill is producing excessive smoke or not performing as expected, check these common causes first. Most issues are resolved by verifying setup, fuel, and airflow.

- Is the grill positioned on a surface allowing unrestricted airflow through the perforated firebox bottom? (Critical for efficient ignition and burning)
- Have you removed all ashes that might be blocking the perforations?
- Are you using dry charcoal (preferred) or seasoned hardwood kept below the top edge of the firebox sides?
- Has the fire had 10–15 minutes to fully heat up (coals glowing and covered in ash for optimal clean burning)?
- Is there any standing water or moisture inside the firebox from recent rain/exposure (must be fully dry for best performance)?

SUNSTONE METAL PRODUCTS LLC.
16004 Central Commerce Dr, Pflugerville Texas 78660.

Business Hours.
Mon. to Thur. 9:00AM to 4:30PM
Closed Fri/Sat/Sun

Tel: 512-487-5116
Toll Free: 888-934-9449 (Technical Support Line)

Must keep copy of your sales slip for proof of purchase.

NAME _____ DATE OF PURCHASE _____

ADDRESS _____

MODEL NO _____ INVOICE NO _____

COMPANY THAT YOU PURCHASED FROM _____

Discover the StarBBQ™ Product Line by Sunstone Metal Products

Explore the innovative **StarBBQ™** series, a premium collection of outdoor cooking solutions from Sunstone Metal Products. All StarBBQ™ products are proudly designed and engineered at our facility in North Austin, Texas. As a **PROUD TEXAS COMPANY**, we remain committed to delivering the highest quality in every product we create.

StarBBQ™ offers versatile options for campfire, camping, and backyard adventures, including smokeless fire pits, portable charcoal grills, and innovative grill inserts—all built with durable materials for reliable performance.



Heavy-Duty Steel Fold-Out Camper Griller
Portable Campfire Grill and Griddle Combo |
STARBBQ-FUFP



24" Smokeless Fire Pit
w/Santa Maria Griller |
STARBBQ-24FPBS/STARBBQ-24SMGRIM



Rocket Stove Camper
Box – Military-Grade
Ammo Can Portable
Charcoal Stove |
STARBBQ-FUFP



24" Smokeless Fire Pit
Base Platform – Ultimate
Versatile Outdoor
Cooking Hub |
STARBBQ-24FPBS



24" Charcoal Griller Base
with Unlimited
Versatility and Upgrades,
like the Cart, Santa
Maria, Hood, Post-Griller
| **STARBBQ-24CHBS**



Ultimate Charcoal
Smoker & Pizza Oven
Combo Grill Cart – All-
in-One Heavy-Duty
Outdoor Cooker |
STARBBQ-34SMK

INDEX DIRECTORY

Section Title	Page
Pre-Installation Customer Checklist	1
STARBBQ-AFCG – Product Dimensions	2
STARBBQ-AFCG – Parts Diagram	3
Step-By-Step Setup Instructions	4
Lighting Your First Fire	5
Fuel & Wood Selection	6
Troubleshooting Guide	7
Warranty Information	8

PACKAGE CONTENTS

- Folding A-Frame Grill Body (cold-rolled steel, powder-coated black, with integrated perforated firebox and cross-braced legs)
- Stainless Steel Cooking Grate (with insulated cool-touch handle)
- Carrying Storage Bag
- User Manual

Note: No additional hardware or tools required; grill is ready to unfold and use out of the box.

Before First Use Checklist

Before setting up and using your STARBBQ-AFCG Folding A-Frame Camper Charcoal Grill for the first time, confirm that all items below are completed. Proper preparation ensures safe operation, optimal airflow for efficient charcoal burning, and enjoyable grilling performance.

- Location & Safety Clearance:** Choose an outdoor usage location that maintains a minimum 10 ft clearance from all buildings, overhangs, tree branches, tents, vehicles, and other combustible materials (refer to the Safety section).
- Local Regulations Verified:** Confirm compliance with all local fire codes, burn bans, camping restrictions, and any air-quality “No-Burn” regulations applicable in your area.
- Ground Surface Prepared:** Verify the setup surface is leveled, stable, and non-combustible, such as bare earth, gravel, sand, or a heat-resistant mat. Avoid grass or flammable surfaces that could ignite.
- Airflow Base Confirmed (Required):** Ensure the grill's A-frame legs are fully extended and positioned on a surface that allows unrestricted airflow to the perforated firebox bottom. (This is essential for proper charcoal ignition and consistent heat.)
- Charcoal Quantity Confirmed:** Purchase sufficient charcoal for your needs: • Standard sessions: approximately 5–10 lbs of lump charcoal or briquettes (Quantity varies based on cooking duration and group size.)
- Grate Surface Suitability Verified (Critical):** Confirm that the stainless steel cooking grate is clean, flat, and free of damage. It must rest securely on the frame supports for even cooking and stability.
- Assembly Checked:** Verify all components (folding frame, firebox, grate, and handle) are securely attached and unfold smoothly without obstruction.
- Safety Gear Ready:** Have proper safety equipment available, including heat-resistant gloves, tongs, and eye protection.
- Fire Safety Equipment Available:** Ensure a bucket of water, sand, or fire extinguisher rated for grease fires is within immediate reach of the grill location.

Opened Dimensions

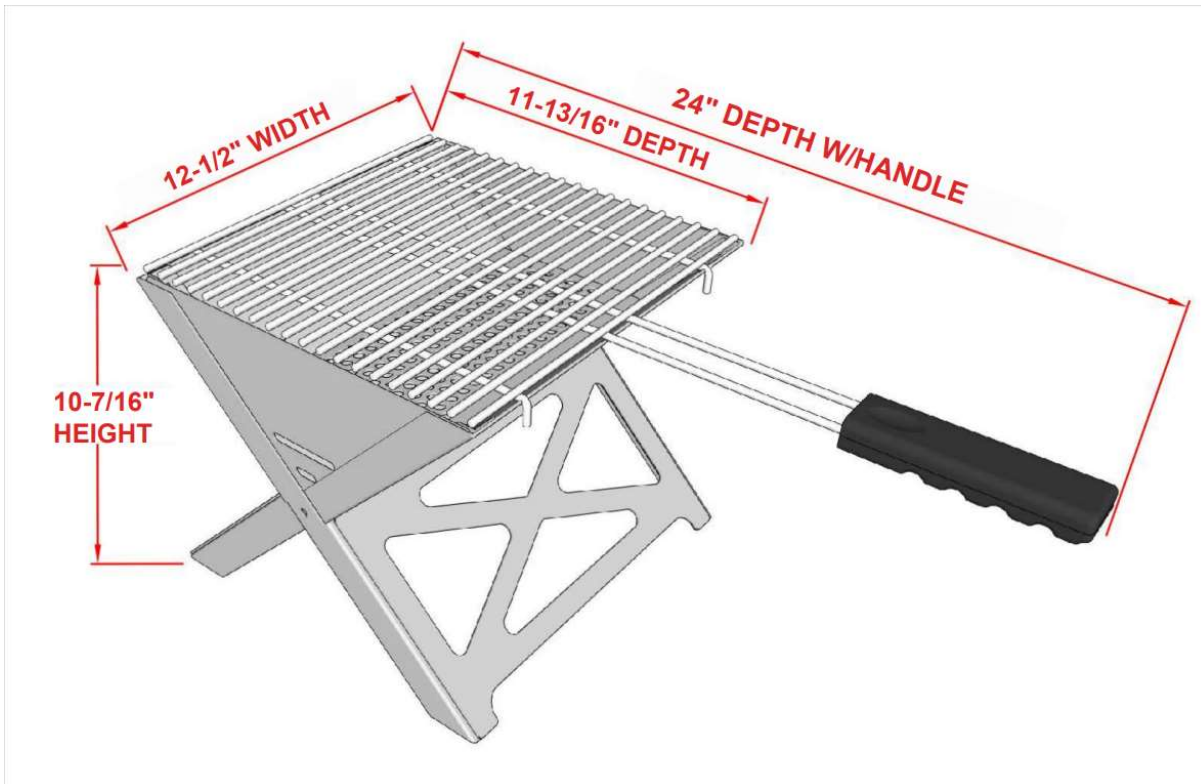

Folded Dimensions

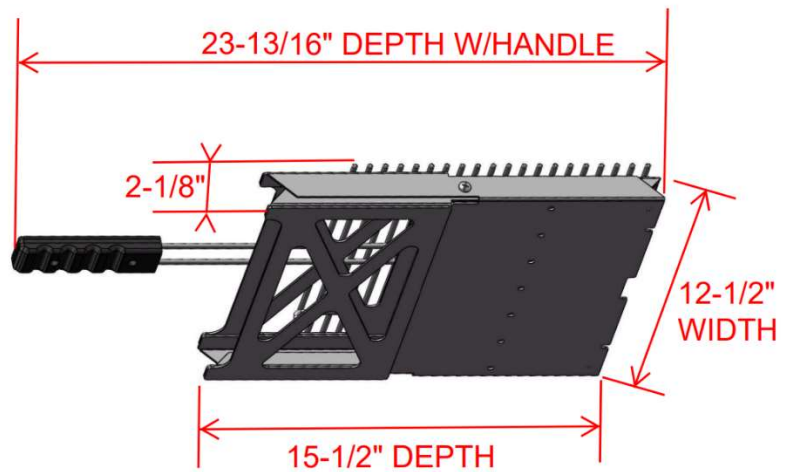

STARBBQ-AFCG— Folding A-Frame Camper Charcoal Grill

- **Product Opened Dimensions:** 24" D x 12-1/2" W x 10-7/16" H
- **Product Folded Dimensions:** 23-13/16" D x 12-1/2" W x 2-1/8" H
- **Material:** Powder-Coated Cold-Rolled Steel
- **Net Weight:** 14.5 Pounds

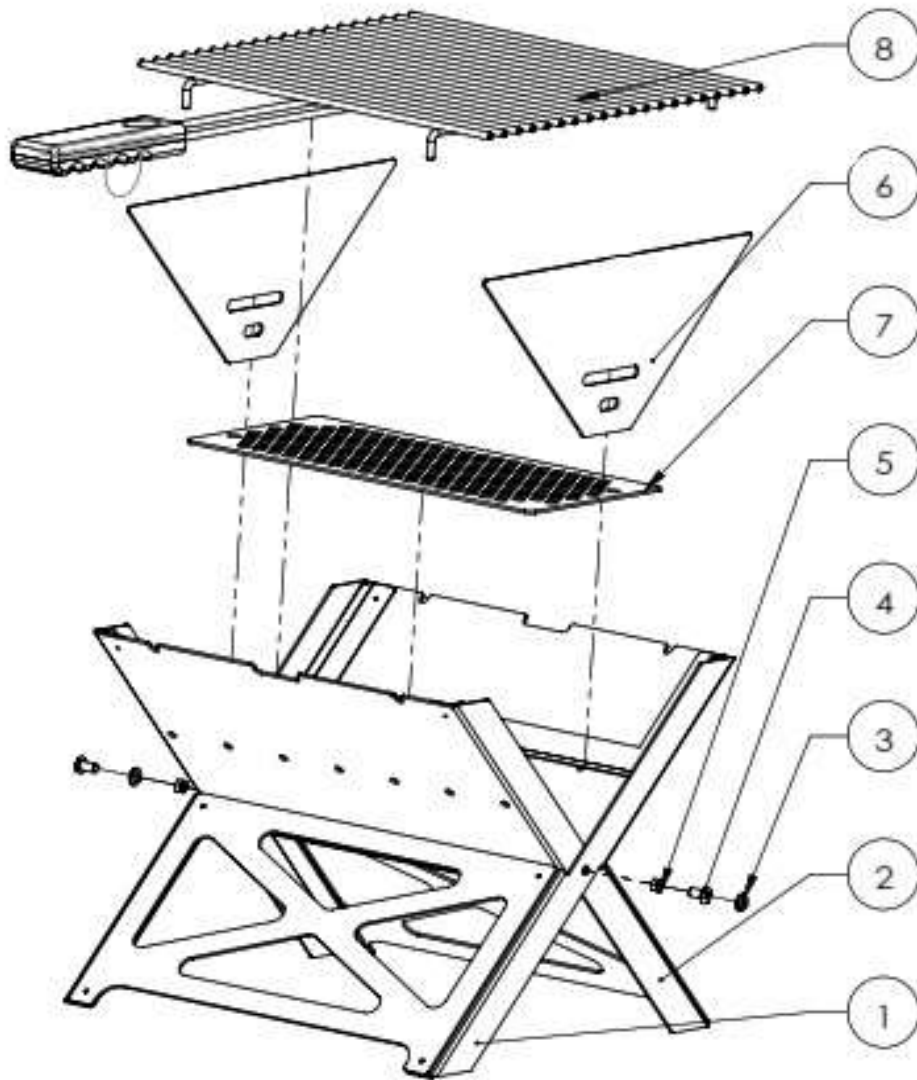

STARBBQ-AFCG

Scissor-Style Charcoal Grill

Item No.	Part Number	Description	Quantity
1	STARBBQ-AFCG-H001X01	Scissor Leg A (Welded)	1
2	STARBBQ-AFCG-H002X01	Scissor Leg B (Welded)	1
3	M6X12X1.0	304 SS Flat Washer	2
4	PYH-06010-012-304	Phillips Large Flat Head Screw	2
5	KXM-06010-304	All-Metal Three-Piece Lock Nut	2
6	STARBBQ-AFCG-B005X01	Movable Side Panel	2
7	STARBBQ-AFCG-B006X01	Ash Collection Tray	1
8	STARBBQ-AFCG-Z002X01	Cooking Grate Assembly	1

1. **Select and Prepare the Usage Location**

Choose a temporary outdoor location that maintains a minimum 10 ft clearance from all buildings, overhangs, tree branches, tents, vehicles, and other combustible materials, including overhead clearance. Confirm the surface is leveled, stable, and non-combustible, such as bare earth, gravel, sand, or a heat-resistant mat. Avoid grass or flammable surfaces that could ignite. Verify all local fire codes, burn bans, camping restrictions, and regulations before proceeding.

2. **Unpack and Inspect the Grill**

Remove the grill from its packaging on a flat surface. Verify all components are present: folding A-frame body with integrated perforated firebox, stainless steel cooking grate with handle, and user manual.

3. **Unfold and Set Up the A-Frame Base (Critical for Stability and Airflow)**

Unfold the cross-braced legs outward until they lock into place, forming a stable A-frame structure. Position the grill on the prepared surface, ensuring the base is elevated slightly above the ground for proper airflow through the perforated firebox. This elevation is mandatory for efficient charcoal ignition and consistent heat. Do not place the grill directly on soft or uneven ground, as this could restrict airflow or cause tipping.

4. **Attach the Cooking Grate**

Place the stainless-steel cooking grate securely onto the frame supports, ensuring it sits flat and level. The insulated cool-touch handle should extend outward for easy access.

5. **Position and Level the Grill**

Confirm the grill is stable and level in all directions. Adjust the leg positions or surface as needed until secure. Proper leveling is critical to ensure even cooking and prevent food from sliding.

6. **Prepare and Add Charcoal**

Arrange a layer of charcoal briquettes or lump charcoal in the perforated firebox, maintaining uniform distribution for even burning. Use approximately 5–10 lbs depending on cooking needs, but do not overfill to avoid restricting airflow. Light the charcoal using matches or a lighter; avoid accelerants like gasoline. Allow it to burn until covered in ash for optimal grilling heat.

Follow these steps carefully to ensure safe ignition, efficient burning, and optimal grilling performance:

Step 1: Start Small Body:

Place a small amount of dry kindling, newspaper, or natural fire starters in the center of the perforated firebox. Arrange 2–4 lbs of charcoal loosely around or over the kindling in a pyramid or mound shape. Avoid tightly packing charcoal during initial lighting.

Step 2: Maintain Proper Load Height Body:

Keep all charcoal below the top edge of the firebox sides. Overloading restricts airflow through the perforations and can cause uneven burning or excessive smoke.

Step 3: Ignition Body:

Light the fire using matches, a lighter, or a chimney starter. Do not use gasoline, lighter fluid, or other chemical accelerants.

Step 4: Initial Smoke Period Body:

Some smoke during the first 10–15 minutes is normal. During this time, the grill is heating up and airflow is establishing for consistent combustion.

Step 5: Optimal Burning Begins Body:

As the charcoal reaches full heat (coals glowing red and covered in ash), airflow through the perforated base optimizes for even, high-heat performance. At this point, smoke will reduce significantly, and the grill is ready for cooking.

Additional Note: Once established, the fire can be maintained by adding small amounts of charcoal as needed, always ensuring even distribution and unrestricted airflow through the perforations.

For the best performance, longest burn time, and minimal smoke—especially in camping situations where wood availability is limited—always prioritize charcoal when possible. Charcoal provides consistent heat, easier lighting, and cleaner burning. When charcoal is unavailable, use dry hardwood found on-site, cut or broken to lengths no longer than 18–20 inches to fit the firebox.

Fuel Type	Characteristics	Recommended Use
Hardwood Charcoal (lump or briquettes)	Consistent high heat, long burn, minimal smoke, easy to light	Primary fuel – ideal for most camping and grilling sessions
Oak	Dense, slow-burning, high heat, excellent coals	Good for longer cooks when available
Hickory	Dense, hot-burning, strong flavor	Excellent for added smoke flavor in meats
Maple	Dense, steady burn, good coals	Reliable all-purpose hardwood
Cherry	Medium heat, sweet aroma	Pleasant for evening grilling
Ash	Burns hot even if slightly damp	Versatile on-site option
Birch	Quick-burning, bright flame	Great as kindling to start the fire
Pine / Fir / Softwoods	High sap, fast burn, heavy smoke	Avoid as primary fuel – use only sparingly for kindling
Elm / Chestnut	Smoky, low heat, sparking	Avoid

Important:

- Never overload the firebox. Keep charcoal or wood below the top edge of the firebox sides. Overloading restricts airflow through the perforations and can cause excessive smoke or uneven burning.
- Maximum recommended load: Use 5–10 lbs of charcoal or equivalent volume of wood pieces for typical sessions. Maintain even distribution for optimal heat.

Folding A-Frame Camper Charcoal Grill Maintenance & Care

1. **Ash Removal:** Dump cool ashes from the firebox after every 2–3 uses or when ash covers the perforated bottom. This maintains essential airflow for efficient burning and quick ignition.
2. **Extinguishing the Fire:** Never pour water on the hot grill, as it may warp the steel. Allow coals to burn out and cool naturally or smother with a metal lid if available.
3. **Weather Protection:** Fold and store the grill in a dry place or protective bag when not in use. Prevent rain or moisture from entering the firebox, as it can block perforations and impair performance until dried. Before lighting in wet or winter conditions, shake out any standing water, snow, or debris from the firebox.

This section addresses common issues with smoky operation, weak fires, instability, excessive sparks, or post-use odors. Solutions are based on the grill's design for optimal airflow and portable charcoal/wood burning.

Q. Grill is smoky (does not burn cleanly).

- Grill not fully heated yet → wait 10–15 minutes after coals are glowing for steady heat and reduced smoke.
- Charcoal/wood is wet or unseasoned → use only dry charcoal or hardwood (≤20% moisture ideal for camping).
- Fire overloaded → keep charcoal/wood below the top edge of the firebox sides.
- Bottom airflow blocked → confirm perforations are clear and grill is elevated slightly on stable ground with no ash buildup.
- Moisture inside firebox → fully dry the firebox before lighting.

Q. Fire starts hard or burns weakly.

- Ash level too high → dump cool ashes until perforated bottom is clear.
- Restricted airflow underneath → reposition on a surface allowing free air flow through perforations (e.g., gravel, sand, or raised ground).
- Using softwood, damp fuel, or debris → switch to dry charcoal (preferred) or seasoned hardwood only.

Q. Grill feels unstable or wobbles.

- Legs not fully extended → unfold A-frame legs completely until locked in place.
- Uneven ground → reposition on level, firm surface and adjust leg placement.
- Components shifted during transport → re-seat the cooking grate firmly on frame supports.

Q. Too many sparks or popping.

- Burning pine/softwood, damp wood, or debris → switch to lump/briquette charcoal or seasoned hardwoods (e.g., oak, hickory, maple) only.

Q. Grill smells or smokes after rain/exposure.

- Moisture trapped inside → shake out water, let firebox air-dry completely (may take 1–2 dry days) before next use.
- Always fold and store in a dry place or protective bag/cover when not in use.



ATTENTION: The A-Frame Camper Grill must be used according to the product manual. If your setup or use does not meet the Basic Setup Instructions and guidelines outlined in this manual, **ALL WARRANTIES MAY BE VOID.**

Warranty Information for STARBBQ-AFCG Folding A-Frame Camper Charcoal Grill. All Warranties Begin on Date of Purchase

LIMITED LIFETIME WARRANTY: Sunstone Metal Products warrants the heavy-gauge cold-rolled steel body and high-temperature powder-coat finish against burn-through, cracking, or structural failure for as long as the original purchaser owns the product when used in normal residential or personal outdoor settings (e.g., camping, tailgating, backyard use). This warranty covers defects in material and workmanship under proper use and maintenance.

LIMITED ONE-YEAR WARRANTY: The stainless-steel cooking grate, insulated handle, and all integrated components are warranted to be free from defects in material and workmanship for a period of one (1) year from the original date of purchase.

Limitations & Exclusions

1. This warranty applies only to the original purchaser and is non-transferable.
2. Warranty is in lieu of all other warranties, expressed or implied.
3. Warranty is void if damage results from misuse, abuse, accident, alteration, improper setup/use (including overloading the firebox or restricting airflow), use of prohibited fuels/accelerants, or failure to follow this manual.
4. Normal cosmetic wear including heat-induced discoloration of the powder-coat finish, minor surface scratches, or fading from prolonged sun exposure is not covered.
5. Sunstone is not responsible for damage caused by acts of nature, excessive moisture, or use in commercial/public settings.
6. Sunstone shall not be liable for incidental, consequential, special, or contingent damages. Some states do not allow the exclusion of consequential damages, so this limitation may not apply to you.
7. No person or dealer has authority to modify or extend this warranty.

What Is Not Covered

- Normal heat tint, discoloration, or fading of powder-coat finish
- Damage from using accelerants, wet/untreated wood, overloading, or softwoods
- Labor, shipping, or travel charges
- Service calls for issues caused by improper use or maintenance
- Damage from failure to store properly (e.g., moisture accumulation, freeze damage)
- Any third-party accessories or modifications
- Commercial or rental use

How to Obtain Warranty Service: Contact Sunstone Metal Products directly: Address: 16004 Central Commerce Dr., Pflugerville, TX 78660 Phone: 888-934-9449 (M–Thur. 8 am–5 pm CST) Email: support@sunstonemp.com Web: sunstonemp.com. Please have your model (STARBBQ-AFCG), proof of purchase, and clear photos ready.