



Product: 30 INCH 17.9 CU. FT. BOTTOM FREEZER REFRIGERATOR IN STAINLESS STEEL

Model Number: TRF3017BF

TECHNICAL DETAILS

Total Capacity (cu. ft.)	17.9 cu. ft.
Refrigerator Capacity (cu. ft.)	12.7 cu. ft.
Freezer Capacity (cu. ft.)	5.27 cu. ft.
Power (Watts)	190W
Amperage (A) Dedicated	15A
Voltage (V)	115V
Frequency (Hz)	60Hz
Plug Type	US 3-Prong
Power Cord Length (in.)	94"
Adjustable Feet / Leveling	2
Door Swing Clearance	150°

PERFORMANCE AND EFFICIENCY

Energy Efficiency Rating	ENERGY STAR
Annual Energy Consumption (kWh/year)	518
Noise Level (dB)	42
Temperature Range (Refrigerator / Freezer)	35-46°F/-10-5°C
Ice Production / Shape	3.97 lbs (1.8kg) per day / crescent
Frost-Free / Auto Defrost Features	Auto Defrost
Operation Temperature	50-109°F/10-43°C

This refrigerator is designed for indoor, household use only.

Specifications subject to change without notice.

FEATURES & BENEFITS

- Super Freezing & Fast Cooling:** Quickly preserves fresh food and rapidly chills drinks, keeping food quality optimal.
- Multi-Air Flow:** Ensures even cooling throughout the fridge, reducing hot spots and keeping all items fresh.
- Interior LED Lighting:** Bright, energy-efficient lighting makes it easy to see all items inside.
- Door Open Alarm:** Alerts users if the door is left open, preventing energy waste and food spoilage.
- LED Display:** Easy-to-read touch control panel for precise temperature management.
- 90° Door Opening Clearance:** Allows convenient access to shelves and drawers, even in tight spaces.
- Inverter Compressor:** Saves energy, reduces noise, and maintains consistent cooling.
- Automatic Ice Maker:** Provides a steady supply of ice without manual effort.
- Adjustable & Removable Shelves:** Flexible storage to fit items of various sizes and simplify cleaning.



GENERAL PROPERTIES

Number of Doors	2
Number of Shelves	3
Number of Freezer Baskets	2
Door Handle Type	Bar Handle
Adjustable & Removable Shelves	Yes
Shelf Material	Glass
Reversible Door Swing	Yes
Soft Closing Door Feature	Yes
Air Filter	No
Lighting Type	LED
Control Type	Touch Control
Display Panel	LED Display
Vacation / Economy / Fast Freeze / Quick Cool Mode	Yes
Child Lock Feature	Yes
Door Open Alarm	Yes
Water Filter	No
Ice Maker	Yes
Water Dispenser	No

DIMENSIONS & WEIGHT

Product Dimensions (WxDxH) (in.)	29-7/8" × 31-3/8" × 70-1/8"
Product Depth (excluding handles) (in.)	29-1/4"
Product Depth (excluding door) (in.)	25-5/8"
Product Depth with Door Open 90° (in.)	56-9/16"
Product Height to Top of Refrigerator (in.)	70-1/8"
Product Height to Top of Door Hinge (in.)	67-15/16"
Cutout Dimensions (WxDxH) (in.)	33-13/16" x 27-9/16" x 72-1/16"
Net Weight (lbs.)	183
Gross Weight (lbs.)	205
Package Dimensions (WxDxH) (in.)	32-3/8" × 30-1/2" × 72-5/8"

ADDITIONAL FEATURES

Refrigerator Features	5 Gallon Bins
	Child Lock / Energy Saving / Quick Cool / Temperature Conversion (°C & °F)
	No frost design
Freezer Features	No frost design
	Interior LED light
	Quick freezing

Specifications subject to change without notice.

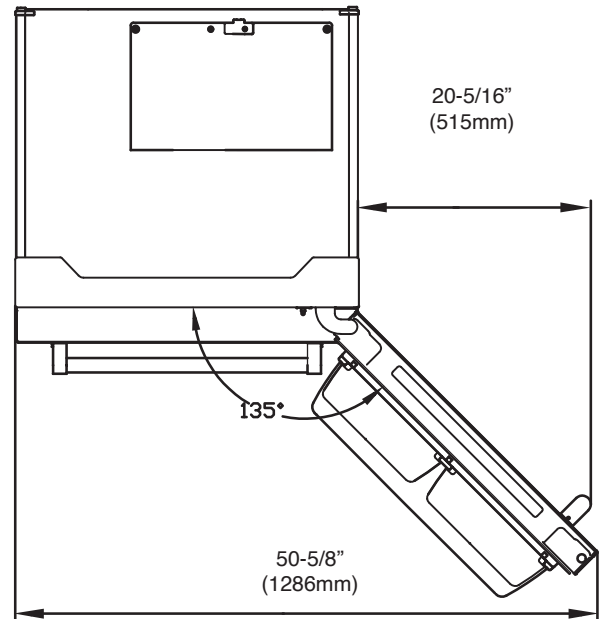
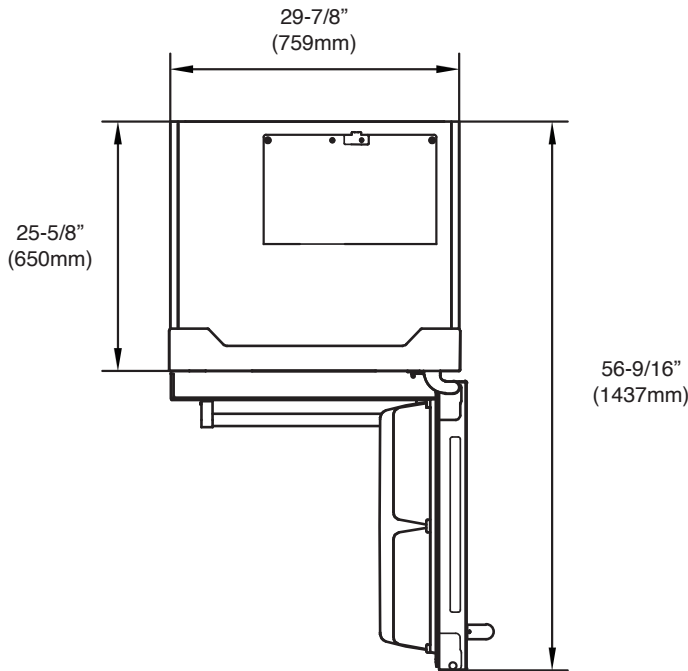
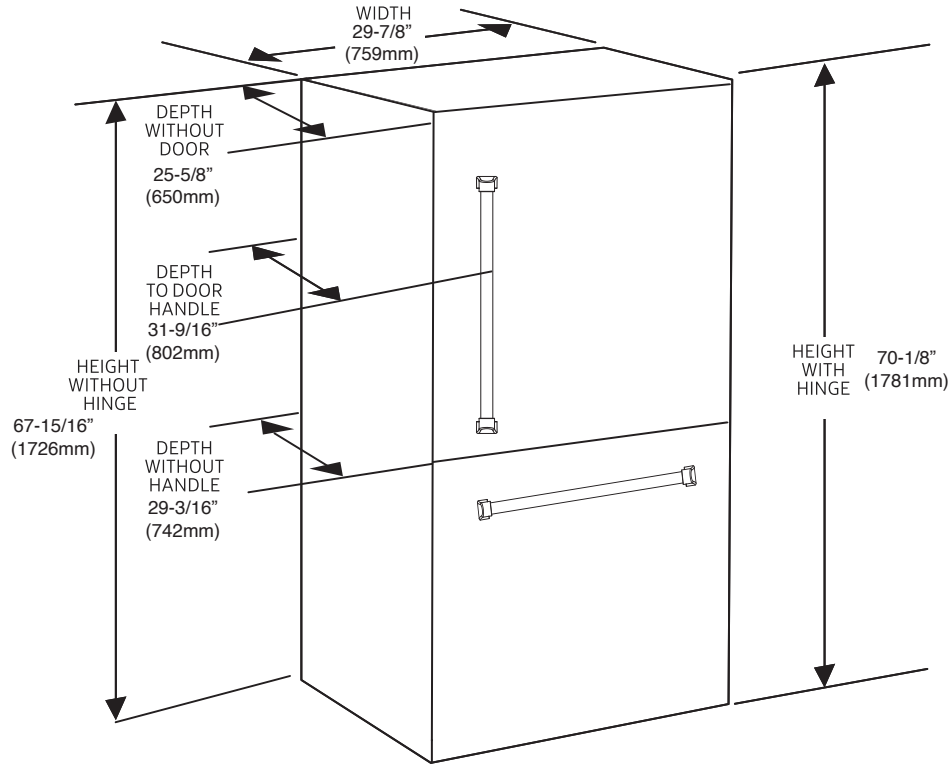

Specifications subject to change without notice.

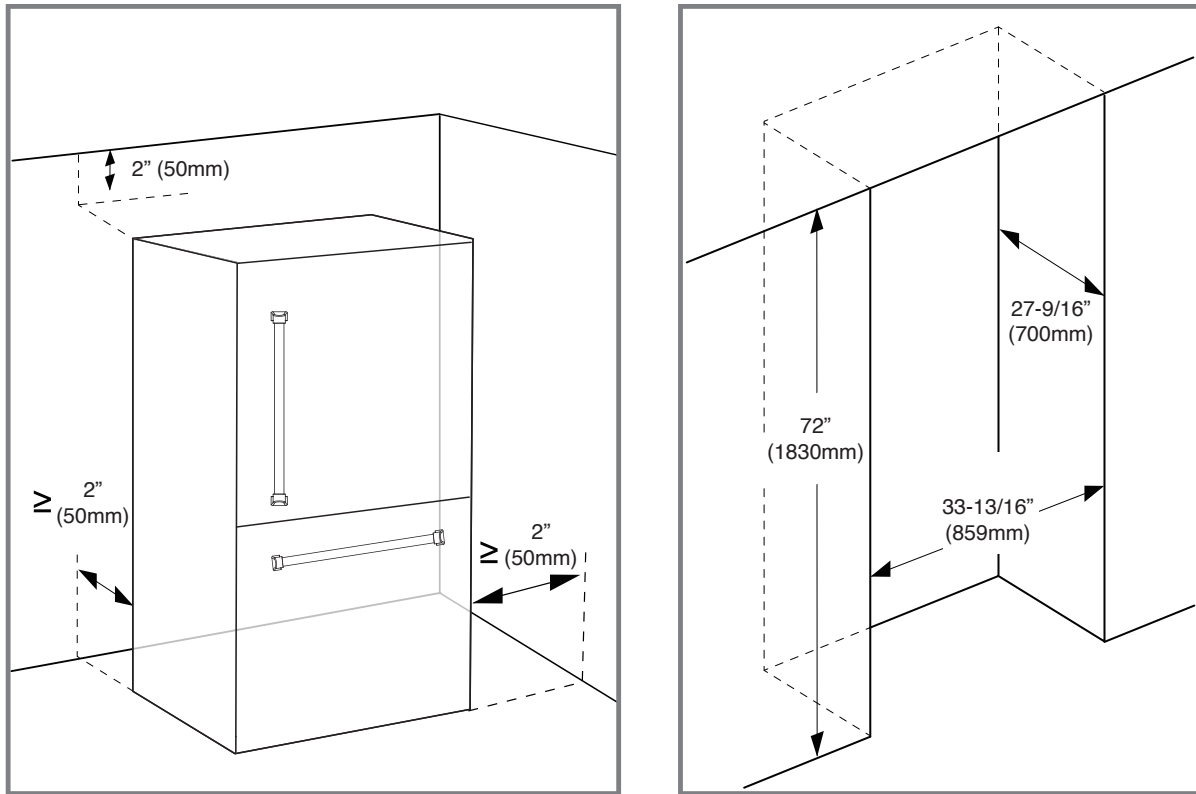

Cutout Dimensions