



HOSHIZAKI

Instruction Manual

Steelheart Series
Refrigerated Kitchen Equipment

Models
Undercounter Side-Mount
Worktop Side-Mount



[hoshizakiamerica.com](https://www.hoshizakiamerica.com)

Issued: 1-19-2024
Revised: 5-13-2025

⚠ WARNING

Only qualified service technicians should install and service the appliance. To obtain the name and phone number of your local Hoshizaki Certified Service Representative, visit www.hoshizakiamerica.com. No installation, operation, or maintenance should be undertaken until the technician has thoroughly read this Instruction Manual. No service should be undertaken until the technician has thoroughly read the service manual available at www.hoshizakiamerica.com. Likewise, the owner/manager should not proceed to operate the appliance until the installer has instructed them on its proper operation. Failure to install, operate, and maintain the appliance in accordance with this manual may adversely affect safety, performance, component life, and warranty coverage. Proper installation is the responsibility of the installer. Product failure or property damage due to improper installation is not covered under warranty.

Hoshizaki provides this manual primarily to assist qualified service technicians in the installation, operation, maintenance, and service of the appliance.

Should the reader have any questions or concerns which have not been satisfactorily addressed, please call, send an e-mail message, or write to the Hoshizaki Technical Support Department for assistance.

Phone: 1-800-233-1940; (770) 487-2331

E-mail: tech-support@hoshizakiamerica.com

HOSHIZAKI AMERICA, INC.

618 Highway 74 South

Peachtree City, GA 30269

Attn: Hoshizaki Technical Support Department

NOTE: To expedite assistance, all correspondence/communication **MUST** include the following information:

- Model Number _____
- Serial Number _____
- Complete and detailed explanation of the problem.

IMPORTANT

This manual should be read carefully before the appliance is installed and operated. Read the warnings and guidelines contained in this manual carefully as they provide essential information for the continued safe use and maintenance of the appliance. Retain this manual for any further reference that may be necessary.

CONTENTS

Important Safety Information	4
I. Specifications.....	10
A. Construction.....	10
B. Electrical and Refrigerant Data	11
1. Refrigerators.....	11
2. Freezers.....	11
II. Installation Instructions	12
A. Location	12
B. Checks Before Installation.....	14
C. Setup.....	14
1. Remove the Appliance from the Pallet	14
2. Check the Refrigeration Circuit.....	16
3. Position the Appliance and Lock the Front Casters	16
4. Install the Shelves.....	16
D. Door Reversal.....	17
E. Door/Drawer Reversal	21
F. Electrical Connection	28
G. Final Checklist	29
III. Operating Instructions.....	30
A. Important Notes About Usage	30
B. Startup	33
C. Controls and Adjustments	33
1. Temperature Display.....	33
2. Adjusting the Temperature Setpoint.....	34
3. Cabinet Temperature Display Scale (°F or °C)	34
D. Cabinet Control Display Icons	35
E. Defrost.....	36
F. Cabinet Control Alarm Safeties	38
G. Food Storage	39
H. Safety Devices	39
I. Cooling Performance	40
J. Cabinet Condensation	40
IV. Maintenance	41
A. Maintenance Schedule.....	41
B. Cleaning	42
V. Prepare the Appliance for Periods of Non-Use	44
VI. Decommissioning and Disposal	45

Important Safety Information

Throughout this manual, notices appear to bring your attention to situations which could result in death, serious injury, damage to the appliance, or damage to property.

	R-290 Class A3 Flammable Refrigerant Used	
⚠ DANGER	Indicates a hazardous situation that, if not avoided, will result in death or serious injury.	
⚠ WARNING	Indicates a hazardous situation that, if not avoided, could result in death or serious injury.	
NOTICE	Indicates a situation that, if not avoided, could result in damage to the appliance or property.	
IMPORTANT	Indicates important information about the use and care of the appliance.	
⚠ DANGER		
<p><u>Risk of Fire or Explosion</u> <u>Flammable Refrigerant Used</u></p> <ul style="list-style-type: none"> • Only qualified service technicians should install and service the appliance. • No installation, operation, or maintenance should be undertaken until the technician has thoroughly read this Instruction Manual. All safety precautions must be followed. • No service should be undertaken until the technician has thoroughly read the Service Manual available at www.hoshizakiamerica.com. All safety precautions must be followed. • This appliance to be installed in accordance with the Safety Standard for Refrigeration Systems ANSI/ASHRAE 15. • Follow handling instructions carefully in compliance with national regulations. • Do not use mechanical devices or other means to accelerate the defrosting process or to clean, other than those recommended by the manufacturer. • Do not puncture refrigerant tubing. Risk of fire or explosion due to puncture of refrigerant tubing; follow handling instructions carefully. 	<ul style="list-style-type: none"> • Servicing shall be done by trained service personnel with certified competence in handling flammable refrigerants to minimize the risk of possible ignition due to incorrect parts or improper service. • Component parts shall be replaced with like components. so as to minimize the risk of possible ignition due to incorrect parts. • Dispose of properly in accordance with federal or local regulations. • Do not pierce or burn. • Be aware that refrigerants may not contain an odor. • Do not damage the refrigeration circuit. • See nameplate for R-290 refrigerant charge: <ul style="list-style-type: none"> • If greater than 114 g (4 oz.), do not install in public corridor or lobby. • If greater than 152 g (5.3 oz.), do not install within 6 m (20 ft) of open flame. 	

⚠ DANGER continued

- The appliance shall be stored in a room without continuously operating ignition sources (for example: open flames, an operating gas appliance, or an operating electric heater).
- Do not place any potential ignition sources in or near the appliance.
- Keep clear of obstruction all ventilation openings in the appliance enclosure or in the structure for building-in.
- No potential sources of ignition are to be used in the searching for or detection of refrigerant leaks.
- Do not use electrical appliances inside the appliance unless they are of the type recommended by the manufacturer.
- Do not store explosive substances such as aerosol cans with a flammable propellant in this appliance.
- Check that cabling will not be subject to wear, corrosion, excessive pressure, vibration, sharp edges, or any other adverse environmental effects. The check shall also take into account the effects of aging or continual vibration from sources such as compressors or fans.
- Ensure that the area is in the open or that it is adequately ventilated before breaking into the system or conducting any hot work. A degree of ventilation shall continue during the period that the work is carried out. The ventilation should safely disperse any released refrigerant and preferably expel it externally into the atmosphere.

**Risque D'Incendie ou D'Explosion
Fluide Frigorigène Inflammable Utilisé**

- Seuls des techniciens de service qualifiés doivent installer et entretenir l'appareil.
- Aucune installation, opération ou maintenance ne doit être entreprise avant que le technicien n'ait lu attentivement ce manuel d'instructions. Toutes les précautions de sécurité doivent être suivies.
- Aucune opération d'entretien ne doit être entreprise avant que le technicien n'ait lu attentivement le manuel d'entretien disponible sur le site www.hoshizakiamerica.com. Toutes les précautions de sécurité doivent être suivies.
- Cet appareil doit être installé conformément à la norme de sécurité pour les systèmes de réfrigération ANSI/ASHRAE 15.
- Suivez attentivement les instructions de manutention conformément aux règlements nationaux.
- Ne pas utiliser de dispositifs mécaniques ou d'autres moyens pour accélérer le processus de dégivrage ou pour nettoyer, autres que ceux recommandés par le fabricant.
- Ne pas perforer la conduite de fluide frigorigène. Risque d'incendie ou d'explosion en cas de perforation d'une canalisation de fluide frigorigène; suivez attentivement les instructions de manutention.
- L'entretien doit être effectué par du personnel formé et certifié pour la manipulation de réfrigérants inflammables afin de réduire au minimum le risque d'inflammation dû à des pièces incorrectes ou à un entretien inadéquat.

⚠ DANGER continued

- Les pièces doivent être remplacées par des pièces similaires, de manière à réduire au minimum le risque d'inflammation dû à des pièces incorrectes.
 - Mettre au rebut conformément aux règlements fédéraux ou locaux.
 - Ne pas percer ou brûler.
 - Attention, les fluides frigorigènes peuvent ne pas dégager d'odeur.
 - Ne pas endommager les composants du circuit de réfrigération.
 - Voir plaque signalétique pour la charge de réfrigérant R-290:
 - Si elle est supérieure à 114 g (4 oz.), ne pas l'installer dans un couloir public ou un hall d'entrée.
 - Si elle est supérieure à 152 g (5,3 oz.), ne pas l'installer à moins de 6 m (20 pi) d'une flamme nue.
 - L'appareil doit être entreposé dans un local ne contenant pas de sources d'inflammation permanentes (flammes nues, appareil à gaz ou dispositif de chauffage électrique en fonctionnement, par exemple).
 - Ne placer aucune source d'inflammation potentielle à l'intérieur ou à proximité de l'appareil.
 - Ne pas obstruer les ouvertures de ventilation dans l'enceinte de l'appareil ou dans la structure d'encastrement.
 - Aucune source potentielle d'inflammation ne doit être utilisée pour rechercher ou détecter des fuites de réfrigérant.
 - Ne pas utiliser d'appareils électriques à l'intérieur de l'appareil, sauf s'ils sont du type recommandé par le fabricant.
 - Ne pas entreposer dans cet appareil des substances explosives telles que des bombes aérosols contenant un gaz propulseur inflammable.
- Vérifier que le câblage ne sera pas soumis à l'usure, à la corrosion, à une pression excessive, à des vibrations, à des arêtes vives ou à tout autre effet environnemental négatif. Le contrôle doit également prendre en compte les effets du vieillissement ou des vibrations continues provenant de sources telles que les compresseurs ou les ventilateurs.
 - S'assurer que la zone est à l'air libre ou qu'elle est correctement ventilée avant de pénétrer dans le système ou d'effectuer un travail à chaud. Une certaine ventilation doit être maintenue pendant la durée des travaux. La ventilation doit permettre de disperser en toute sécurité tout réfrigérant libéré et, de préférence, de l'expulser dans l'atmosphère.

WARNING

- The appliance should be destined only to the use for which it has been expressly conceived. Any other use should be considered improper and therefore dangerous. The manufacturer cannot be held responsible for injury or damage resulting from improper, incorrect, and unreasonable use. Failure to install, operate, and maintain the appliance in accordance with this manual will adversely affect safety, performance, component life, and warranty coverage and may result in costly water damage.
To reduce the risk of death, electric shock, serious injury, or fire, follow basic precautions including the following:
 - This appliance is not intended for use above 2,000 m (6,561 ft). Installation above 2,000 m (6,561 ft) may adversely affect safety, performance, and component life.
 - Wear appropriate personal protective equipment (PPE) when servicing the appliance.
 - The appliance must be installed in accordance with applicable national, state, and local codes and regulations.
 - The appliance requires an independent power supply of proper capacity. See the nameplate for electrical specifications. Failure to use an independent power supply of proper capacity can result in a tripped breaker, blown fuse, damage to existing wiring, or component failure. This could lead to heat generation or fire.
 - Appliance is heavy. Use care when lifting or positioning. Work in pairs when needed to prevent injury or damage. Do not lift using the top section or the doors/drawers.
- **THE APPLIANCE MUST BE GROUNDED.** The appliance is equipped with a NEMA 5-15 three-prong grounding plug  to reduce the risk of potential shock hazards. It must be plugged into a properly grounded, independent 3-prong wall outlet. If the outlet is a 2-prong outlet, it is your personal responsibility to have a qualified electrician replace it with a properly grounded, independent 3-prong wall outlet. Do not remove the ground prong from the power cord and do not use an adapter plug. Failure to follow these instructions may result in death, electric shock, or fire.
 - To reduce the risk of electric shock, do not touch the control module or plug with damp hands.
 - To reduce the risk of electric shock, make sure the appliance is "OFF" before plugging in or unplugging the appliance.
 - Unplug the appliance before servicing.
 - Do not use an appliance with a damaged power cord. The power cord should not be altered, jerked, bundled, weighed down, pinched, or tangled. Such actions could result in electric shock or fire. To unplug the appliance, be sure to pull the plug, not the cord, and do not jerk the cord.
 - Do not use an extension cord.
 - If the supply cord is damaged, it must be replaced by the manufacturer, its service agent, or similarly qualified persons in order to avoid a hazard. Upon replacement, the GREEN ground wire in the power cord must be connected to the designated grounding screw.
 - Do not make any alterations to the appliance. Alterations could result in electric shock, injury, fire, or damage to the appliance.

⚠ WARNING continued

- The appliance is not intended for use by persons (including children) with reduced physical, sensory, or mental capabilities, or lack of experience and knowledge, unless they have been given supervision or instruction concerning use of the appliance by a person responsible for their safety.
- Do not splash, pour, or spray water directly onto or into the appliance. This might cause short circuit, electric shock, corrosion, or failure.
- Children should be supervised to ensure that they do not play with the appliance.
- Do not climb, stand, or hang on the appliance or doors/drawers or allow children or animals to do so. Do not climb into the appliance or allow children or animals to do so. Death or serious injury could occur or the appliance could be damaged.
- Be careful not to pinch fingers when opening and closing the door. Be careful when opening and closing the door when children are in the area.
- Open and close the doors/drawers with care. Opening the doors/drawers too quickly or forcefully may cause injury or damage to the appliance or surrounding equipment.
- Do not use combustible spray or place volatile or flammable substances in or near the appliance. They might catch fire.
- Do not throw anything onto the shelves or load any single shelf with more than 120 lb. (54.5 kg) of product. They might fall off and cause injury.
- Do not load any single drawer with more than 75 lb. (34 kg) of product. Depending on the weight of product in the drawers, secure the appliance as necessary to prevent it from overturning. Do not open more than one drawer at a time.

- Do not place any product on the floor of the cabinet. All product must be placed on properly installed shelves.
- Keep the area around the appliance clean. Dirt, dust, or insects in the appliance could cause harm to individuals or damage to the equipment.
- Do not block air inlets or outlets, otherwise cooling performance may be reduced.
- Do not tightly pack the cabinet. Allow some space between items to ensure good air flow. Also allow space between items and interior surfaces.
- Do not put warm or hot foods in the cabinet. Let them cool first, or they will raise the cabinet temperature and could deteriorate other foods in the cabinet or overload the appliance.
- Food storage and handling must comply with applicable codes and regulations.
- All foods should be wrapped in plastic film or stored in sealed containers. Otherwise foods may dry up, pass their smells onto other foods, cause frost to develop, result in poor appliance performance, or increase the likelihood of cross-contamination. Certain dressings and food ingredients, if not stored in sealed containers, may accelerate corrosion of the evaporator, resulting in failure.
- Do not store items near air outlets. Otherwise, items may freeze up and crack or break causing a risk of injury or contamination of other food.
- The appliance is designed only for temporary storage of food. Employ sanitary methods. Use for any other purposes (for example, storage of chemicals or medical supplies such as vaccine and serum) could cause deterioration of stored items.

NOTICE

- Install the appliance in a location that stays above freezing. Normal operating ambient temperature must be within 45°F to 100°F (7°C to 38°C).
- Do not leave the appliance on during extended periods of non-use, extended absences, or in sub-freezing temperatures. To properly prepare the appliance for these occasions, follow the instructions in "V. Preparing the Appliance for Periods of Non-Use."
- Do not leave the doors/drawers open.
- Protect the floor when moving the appliance to prevent damage to the floor.
- Do not allow the appliance to bear any outside weight.
- Keep ventilation openings, in the appliance enclosure or in the built-in structure, clear of obstruction.
- The factory-installed rear bumpers must be in place to ensure proper rear clearance. Blockage of airflow could negatively affect performance and damage the appliance.
- To prevent deformation or cracks, do not spray insecticide onto the plastic parts or let them come into contact with oil.
- To avoid damage to the gasket, use only the door handle when opening and closing.

I. Specifications

A. Construction

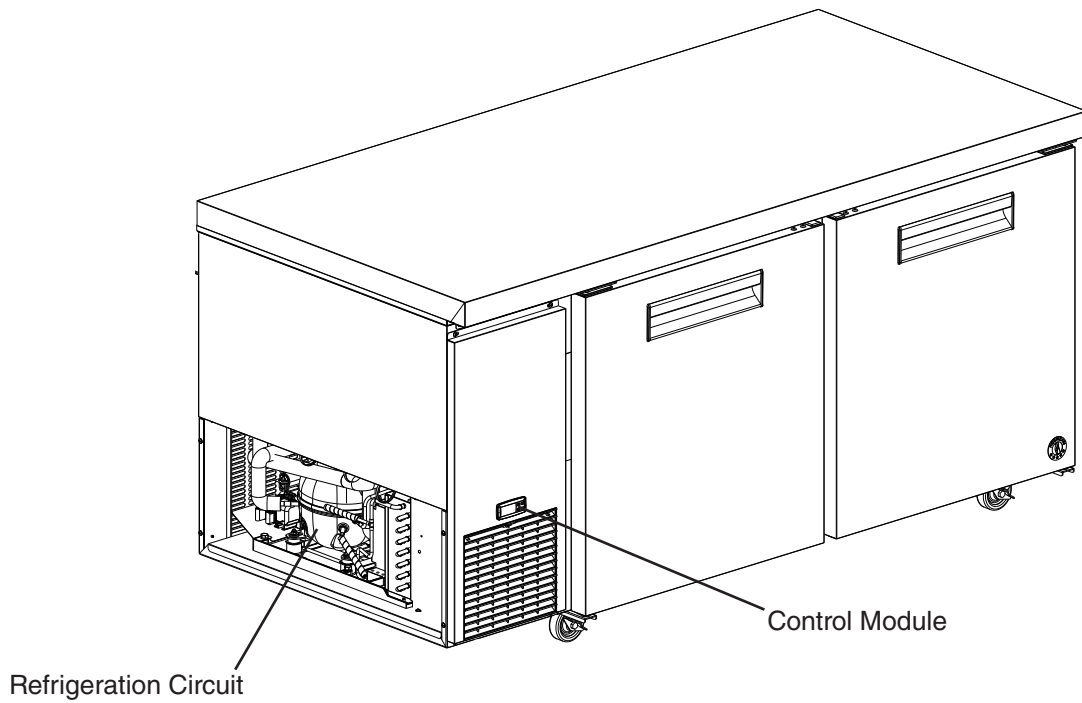
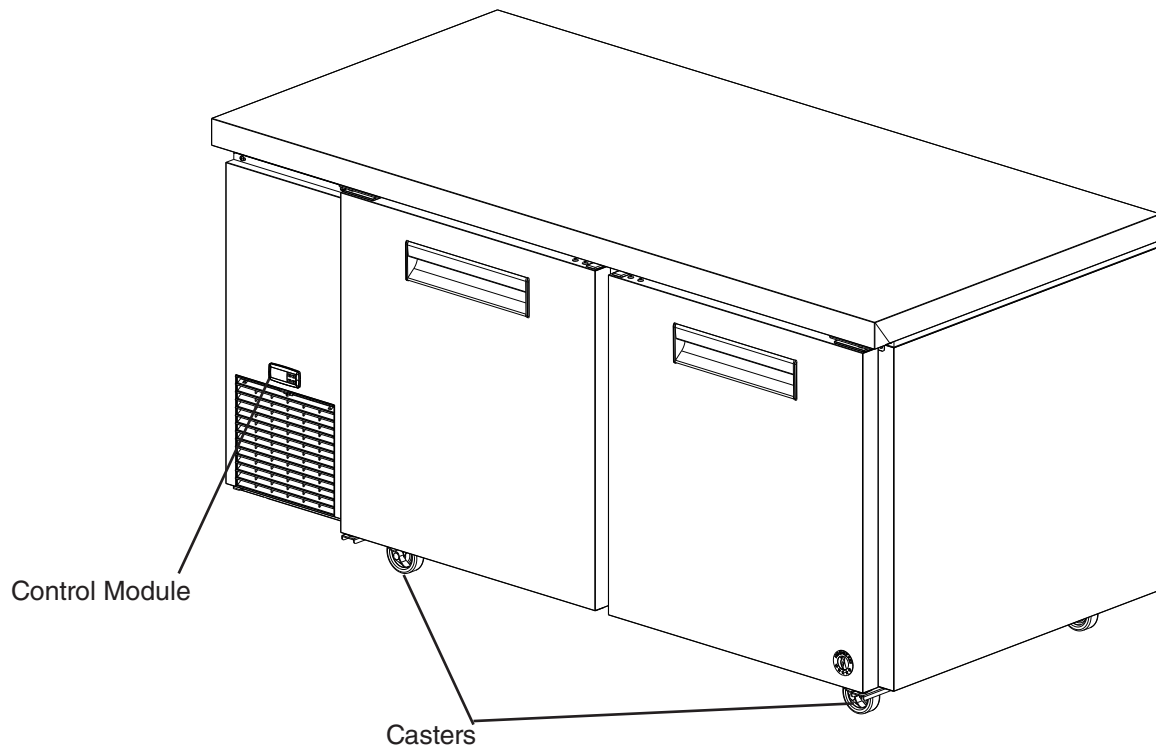

Model Shown: ULR67B

B. Electrical and Refrigerant Data

The nameplate provides electrical and refrigerant data and Year of Manufacture (YOM). The nameplate is located inside the cabinet on the right wall. For certification marks, see the nameplate.

We reserve the right to make changes in specifications and design without prior notice.

1. Refrigerators

Model Number	ULR/WLR46B(-D2)(-D4), ULR/WLR60B(-D2)(-D4), ULR/WLR67B(-D2)(-D4)
AC SUPPLY VOLTAGE	~115/60/1
AMPERES	3.0
DESIGN PRESSURE kPa (PSI)	HI-2482 (360) LO-1310 (190)
REFRIGERANT g (oz.)	R-290 62 (2.2)
CLIMATIC CLASS	5
INSULATION BLOWING GAS	HFO 1233zd(E)
MINIMUM ROOM FLOOR AREA m ² (ft ²)	3.0 (31.9)

Model Number	ULR/WRL93B(-D2)(-D4)(-D6)
AC SUPPLY VOLTAGE	~115/60/1
AMPERES	5.0
DESIGN PRESSURE kPa (PSI)	HI-2482 (360) LO-1310 (190)
REFRIGERANT g (oz.)	R-290 68.4 (2.4)
CLIMATIC CLASS	5
INSULATION BLOWING GAS	HFO 1233zd(E)
MINIMUM ROOM FLOOR AREA m ² (ft ²)	3.3 (35)

2. Freezers

Model Number	ULF/WLF46B
AC SUPPLY VOLTAGE	~115/60/1
AMPERES	4.0
DESIGN PRESSURE kPa (PSI)	HI-2482 (360) LO-1310 (190)
REFRIGERANT g (oz.)	R-290 75 (2.6)
CLIMATIC CLASS	5
INSULATION BLOWING GAS	HFO 1233zd(E)
MINIMUM ROOM FLOOR AREA m ² (ft ²)	3.6 (38.6)

Model Number	ULF/WLF60B/ULF/WLF67B
AC SUPPLY VOLTAGE	~115/60/1
AMPERES	5.0
DESIGN PRESSURE kPa (PSI)	HI-2482 (360) LO-1310 (190)
REFRIGERANT g (oz.)	R-290 80 (2.8)
CLIMATIC CLASS	5
INSULATION BLOWING GAS	HFO 1233zd(E)
MINIMUM ROOM FLOOR AREA m ² (ft ²)	3.8 (41.2)



Note: Climatic Class 5: This appliance electrical safety tested for operation in maximum ambient temperature of 104°F (40°C) with 40% relative humidity. However, normal operating ambient temperature for refrigerator and solid door freezers must be within 45°F to 100°F (7°C to 38°C) and for glass door freezers 45°F to 80°F (7°C to 27°C). Operation of the appliance, for extended periods, outside of these normal temperature ranges may affect appliance performance.

II. Installation Instructions

A. Location

This appliance is approved for indoor use.

This appliance uses an A3 flammable refrigerant. For refrigerant charge and minimum room floor area, see the table below.

⚠ DANGER		
	R-290 Class A3 Flammable Refrigerant Used	
Model	R-290 Refrigerant Charge g (oz.)	Minimum Room Floor Area (operating or storage) Superficie Minimale du Local (service ou stockage) m ² (ft ²); m ² (pi ²)
ULR/WLR46B(-D2)(-D4)/ULR/WLR60B(-D2)(-D4)/ ULR/WLR67B(-D2)(-D4)	62 (2.2)	3.0 (31.9)
ULR/WLR93B(-D2)(-D4)(-D6)	68 (2.4)	3.3 (35)
ULF/WLF46B	73 (2.6)	3.6 (38.6)
ULFWLF60B/ULF/WLF67B	80 (2.8)	38 (41.2)
⚠ DANGER continued		
		
<p>≥ Area m² (ft²) (see "Minimum Room Floor Area" above)</p> <p>≥ Superficie m² (pi²) (voir « Superficie Minimale du Local » ci-dessus)</p>		

⚠ DANGER continued

R-290 Refrigerant Charge:

- If greater than 114 g (4 oz.), do not install in public corridor or lobby.
- If greater than 152 g (5.3 oz.), do not install within 6 m (20 ft) of open flame.

Charge de réfrigérant R-290:

- Si elle est supérieure à 114 g (4 oz.), ne pas l'installer dans un couloir public ou un hall d'entrée.
- Si elle est supérieure à 152 g (5,3 oz.), ne pas l'installer à moins de 6 m (20 pi) d'une flamme nue.

This appliance is not intended for use above 2,000 m (6,561 ft). Installation above 2,000 m (6,561 ft) may adversely affect safety, performance, and component life.

⚠ WARNING

- This appliance must be installed in accordance with all applicable national, state, and local regulations.
- Failure to install, operate, and maintain the appliance in accordance with this manual will adversely affect safety, performance, component life, and warranty coverage.
- Appliance is heavy. Use care when lifting or positioning. Work in pairs when needed to prevent injury or damage. Do not lift using the refrigeration area, the top section, or the doors/drawers.
- Do not tilt the appliance more than 45°.

For best operating results:

- The appliance should not be located next to ovens, grills, or other high heat producing equipment.
- The location should provide a firm and level foundation for the appliance.
- The appliance should not be located in a corrosive environment.
- The factory-installed rear bumpers must be in place to ensure proper rear clearance.

For undercounter and worktop models, a minimum of 1.5" (4 cm) overhead clearance should be provided for proper ventilation.

B. Checks Before Installation

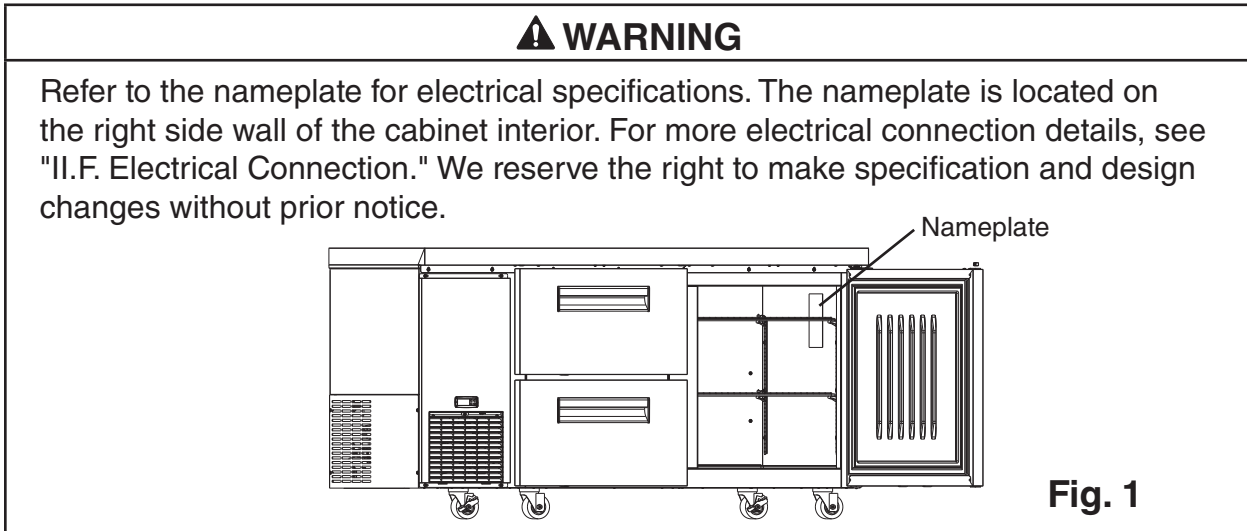

- Visually inspect the exterior of the shipping package and immediately report any damage to the carrier. Upon opening the package, any concealed damage should also be immediately reported to the carrier.
- Remove the shipping carton, tape, and packing material. Also remove the protective plastic film from both the exterior panels. If the appliance is exposed to the sun or to heat, remove the film after the appliance cools.
- Remove all accessory containers before discarding the packing materials. Dispose of all packing materials in a proper and environmentally responsible manner.
- Check for missing or damaged accessories.

C. Setup

1. Remove the Appliance from the Pallet

- 1) Move as close to the permanent location as possible.
- 2) Remove the 2 bolts securing the appliance to the pallet, then remove the appliance from the pallet. Block the appliance securely at a height of 8" (20 cm) off the floor. Place the blocks at the inside area next to the caster holes. See Fig. 2.

NOTICE! Do not place the blocks under the refrigeration area or under the doors or drawers of the appliance. Do not lay the appliance down.

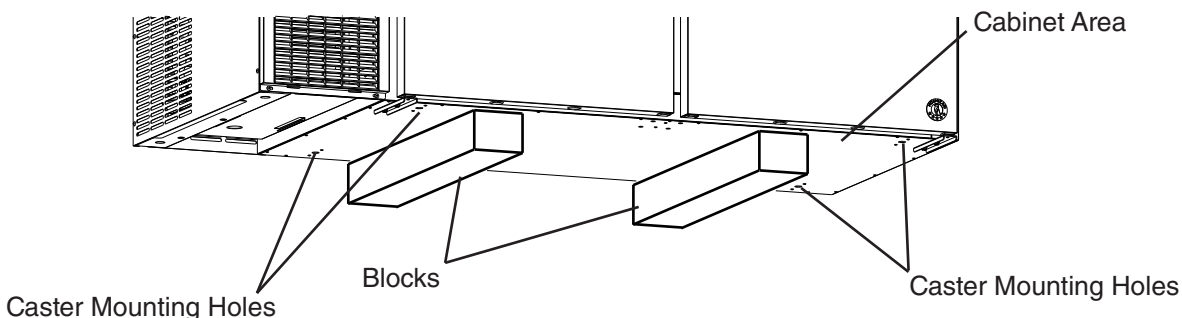

Model Shown: ULR67B

3) Attach the casters to the bottom of the appliance. Locking casters should be attached to the front of the appliance. See Fig. 3a, 3b, or 3c. **NOTICE! Do not place blocks under the refrigeration area or doors/drawers of the appliance. Do not lay the appliance down.**

- a) **XLX46B(-D2):** Attach all 6 casters. See Fig. 3a. **WARNING! On XLX46B(-D2) models, all 6 casters must be installed. Otherwise, appliance may tip.**
NOTICE! Ensure casters are completely threaded into the appliance and tight.

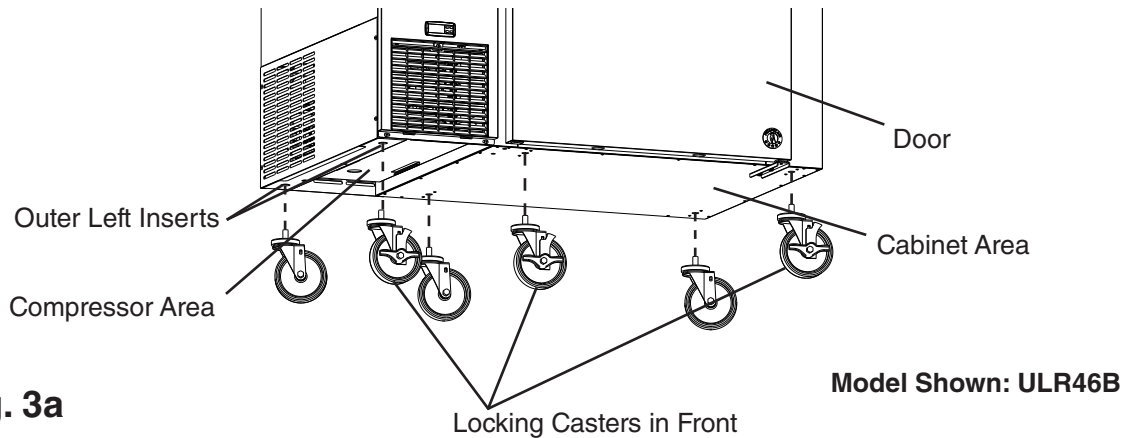

Fig. 3a

- b) **XLX60B(-DX) and XLX67B(-DX):** Attach the 4 casters under the cabinet area. See Fig. 3b. **WARNING! Do not attach the casters under the compressor area in the outer left inserts.** **NOTICE! Ensure casters are completely threaded into appliance and tight.**

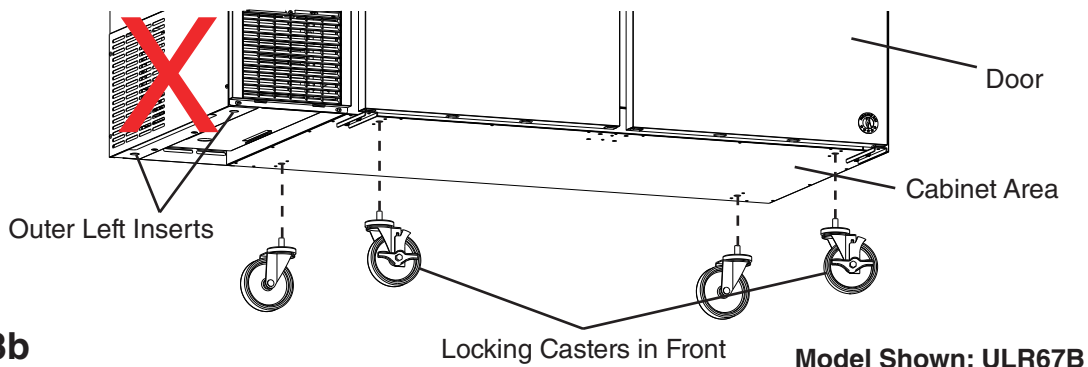

Fig. 3b

- c) **XLX93B(-DX):** Attach the 6 casters under the cabinet area. See Fig. 3c. **WARNING! Do not attach the casters under the compressor area in the outer left inserts.** **NOTICE! Ensure casters are completely threaded into appliance and tight.**

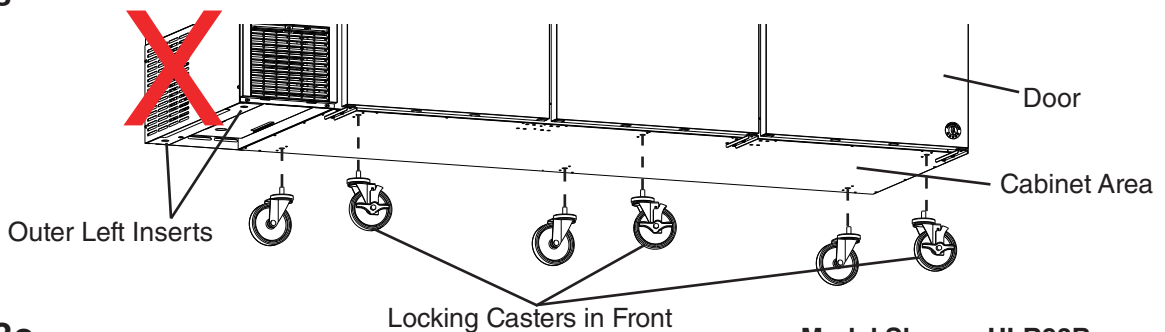

Fig. 3c

2. Check the Refrigeration Circuit

Visually check that the refrigerant lines do not rub or touch other lines or surfaces and that the condenser fan blade turns freely.

3. Position the Appliance and Lock the Front Casters

The front casters on the appliance are lockable. After positioning the appliance in its permanent location, lock the front casters.

4. Install the Shelves

- 1) For each shelf, place the shelf support clips into the pilasters at the desired height (4 shelf support clips per shelf). See Fig. 4.
- 2) Place the shelves in position on the support clips.

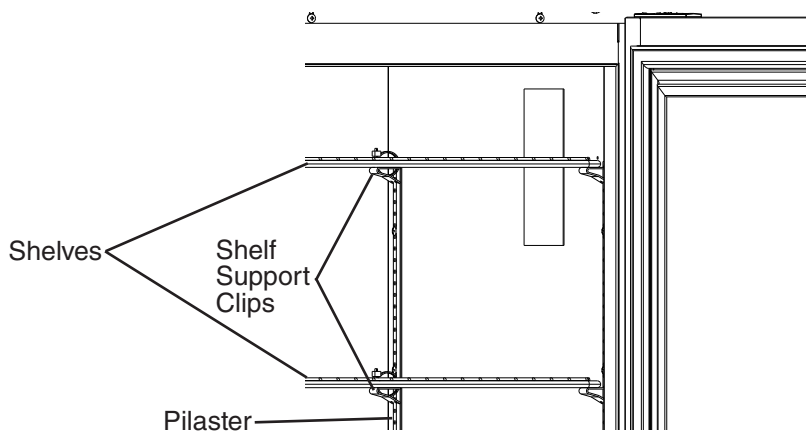

Fig. 4

D. Door Reversal

The appliance is provided with a cabinet design which, after being delivered to the installation location, permits changing of the door swing from left to right or right to left. To change the door swing, follow the steps below. Example shows change from right hinged to left hinged.

⚠ WARNING

- Wear proper PPE (personal protection equipment) when executing these procedures (safety glasses and gloves).
- Keep fingers away from edge of upper hinge bracket. Spring cartridge can cause the upper hinge bracket to move suddenly with extreme force.

Door and Lower Hinge Removal and Relocation

- 1) Remove all items from the appliance. Make sure the appliance is unplugged from the electrical outlet. Move the appliance out for ease of access then lock the casters.
- 2) With the door closed, loosen, but do not remove, the upper hinge bracket outer screw. See Fig. 5. Next, open the door to the fully open position and remove the upper hinge bracket inner screw. See Fig. 6.
- 3) Slide the upper hinge bracket out from under the outer screw and remove the door.
WARNING! Keep away from upper hinge bracket. Upper hinge bracket may spring closed.
- 4) Replace the upper hinge bracket inner screw in its original position and tighten, then tighten the upper hinge bracket outer screw.

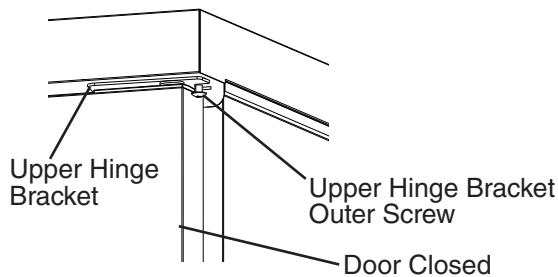

Fig. 5

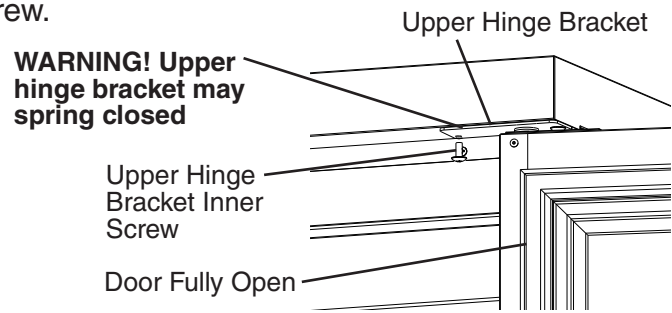

Fig. 6

- 5) Remove the lower hinge bracket. See Fig. 7. Be sure to leave the thrust washer in place.
- 6) Clear the foam from the lower hinge bracket mounting holes prior to securing lower hinge bracket in its new location. Install the lower hinge bracket in its new location. Be sure the lower hinge bracket is pushed all the way in and the thrust washer is in its original position. See Fig. 8.

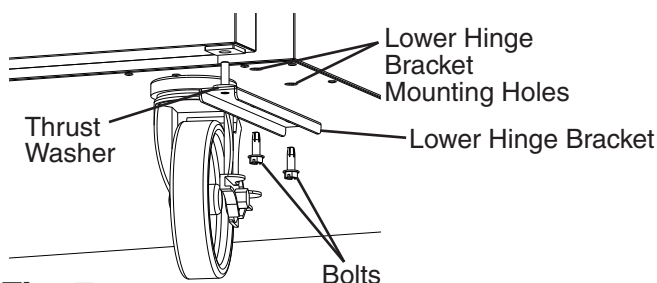

Fig. 7

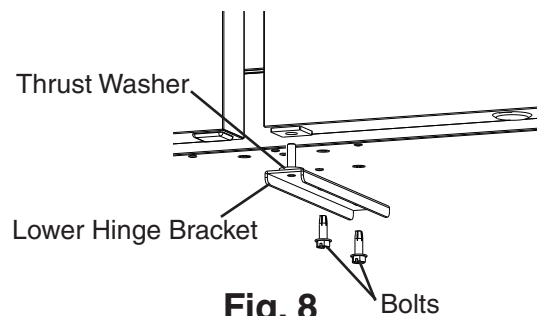
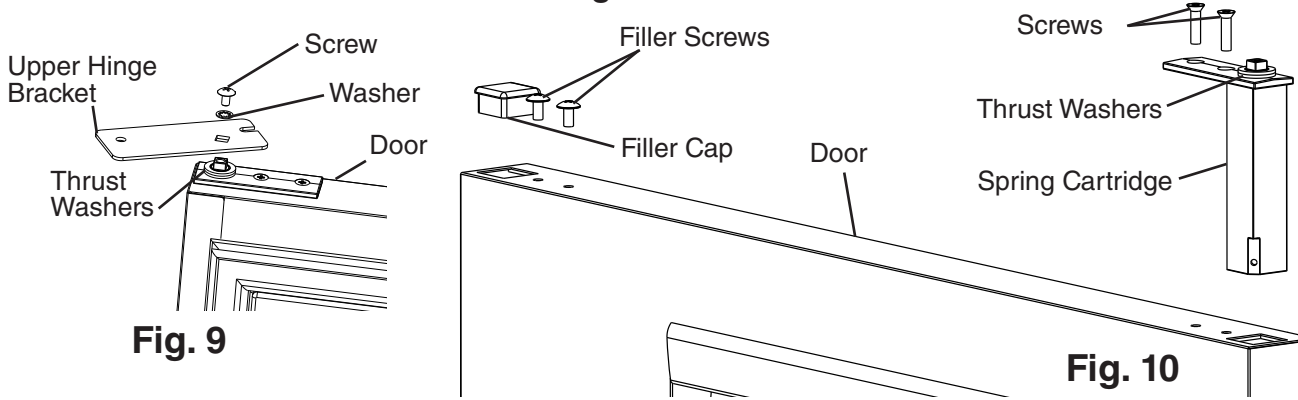

Fig. 8

Upper Hinge Bracket Removal and Spring Cartridge Relocation

- 7) While preventing the upper hinge bracket from rotating, remove the upper hinge bracket from the spring cartridge. See Fig. 9. Note which side of the upper hinge bracket is facing up.
- 8) Remove the filler cap, filler screws, and spring cartridge. See Fig. 10. Leave the thrust washers in place on the spring cartridge. **NOTICE! Spring cartridge may be difficult to remove. Be careful not to damage the finish.**



- 9) Clear foam from the spring cartridge hole to allow for spring cartridge installation. See Fig. 11. Install the spring cartridge in its new location. Reinstall the filler cap and filler screws on the opposite side of the door.

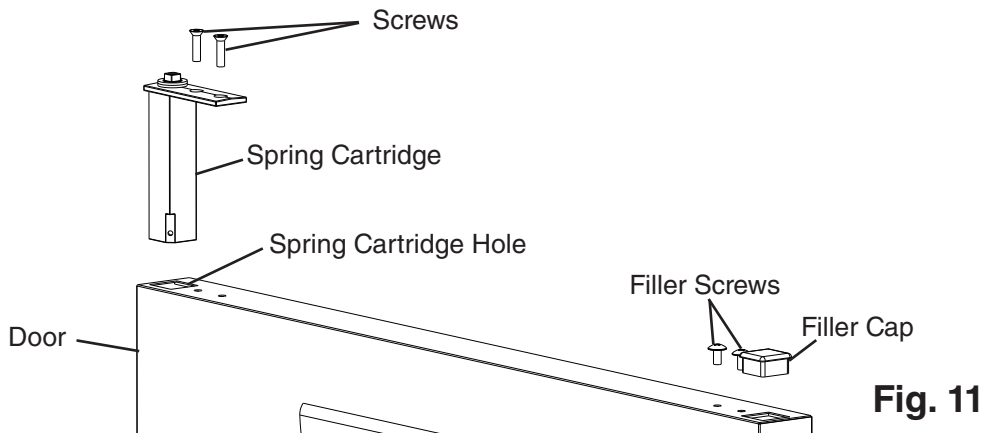

Lower Door Prep and Upper Hinge Bracket Relocation

- 10) Remove the filler cap and nylon bearing from the bottom of the door. See Fig. 12. Reinstall on the opposite side.
- 11) Make sure the thrust washers are in place on the spring cartridge, then flip the upper hinge bracket over from its original position and install onto the spring cartridge in the door open position. See Fig. 13. The upper hinge bracket should be positioned as shown.

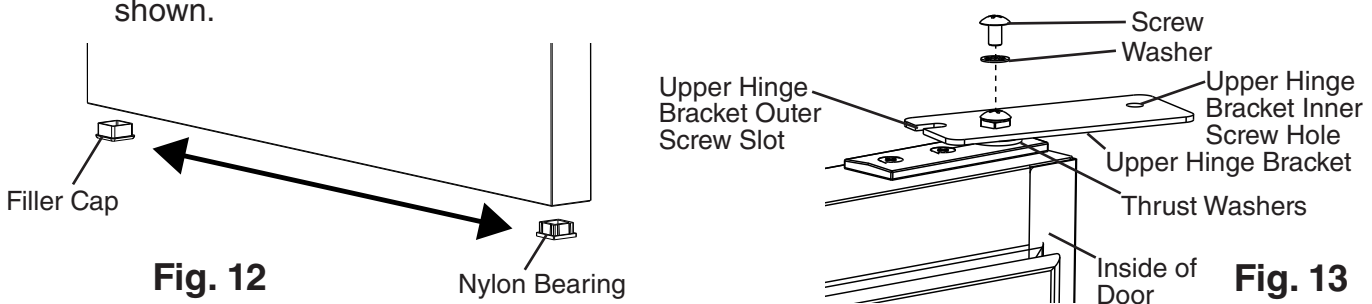

Door Installation

- 12) Remove the black plastic filler cap located from the hole above where the spring cartridge screw will line up. Note: The black plastic filler cap is not reusable.
- 13) Remove the upper hinge bracket screws from the new location and apply Loctite Threadlocker Blue 242 or 243 to the threads. Next, start the upper hinge bracket outer screw into the appliance. Rotate a few threads into the appliance; do not tighten the screw. See Fig. 14.

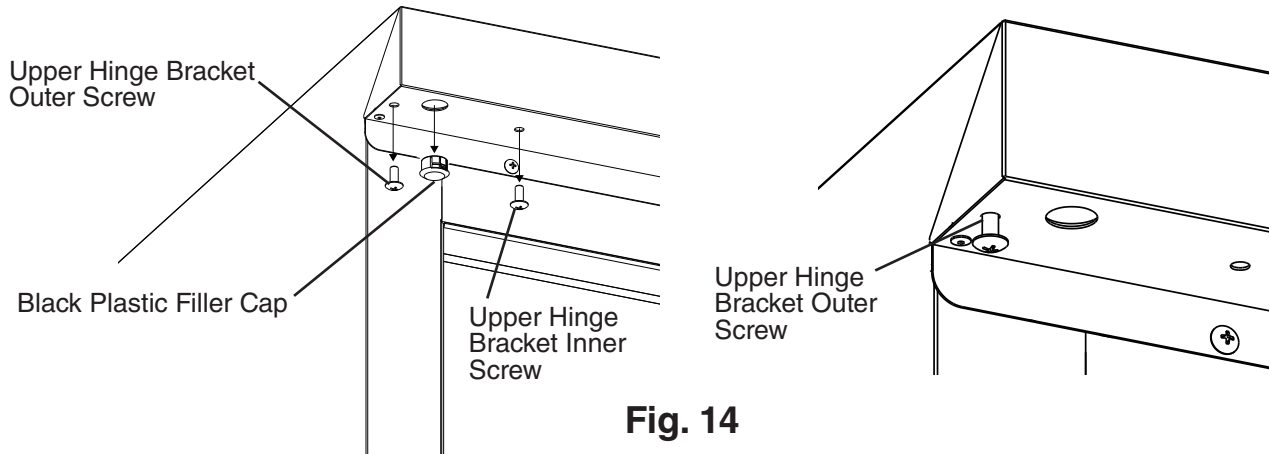

Fig. 14

- 14) Be sure the lower hinge bracket thrust washer is in place, then place the door on the lower hinge bracket in the fully open position. Slide the door upper hinge bracket outer slot onto the upper hinge bracket outer screw. See Fig. 15.
- 15) Install the upper hinge bracket inner screw and tighten.

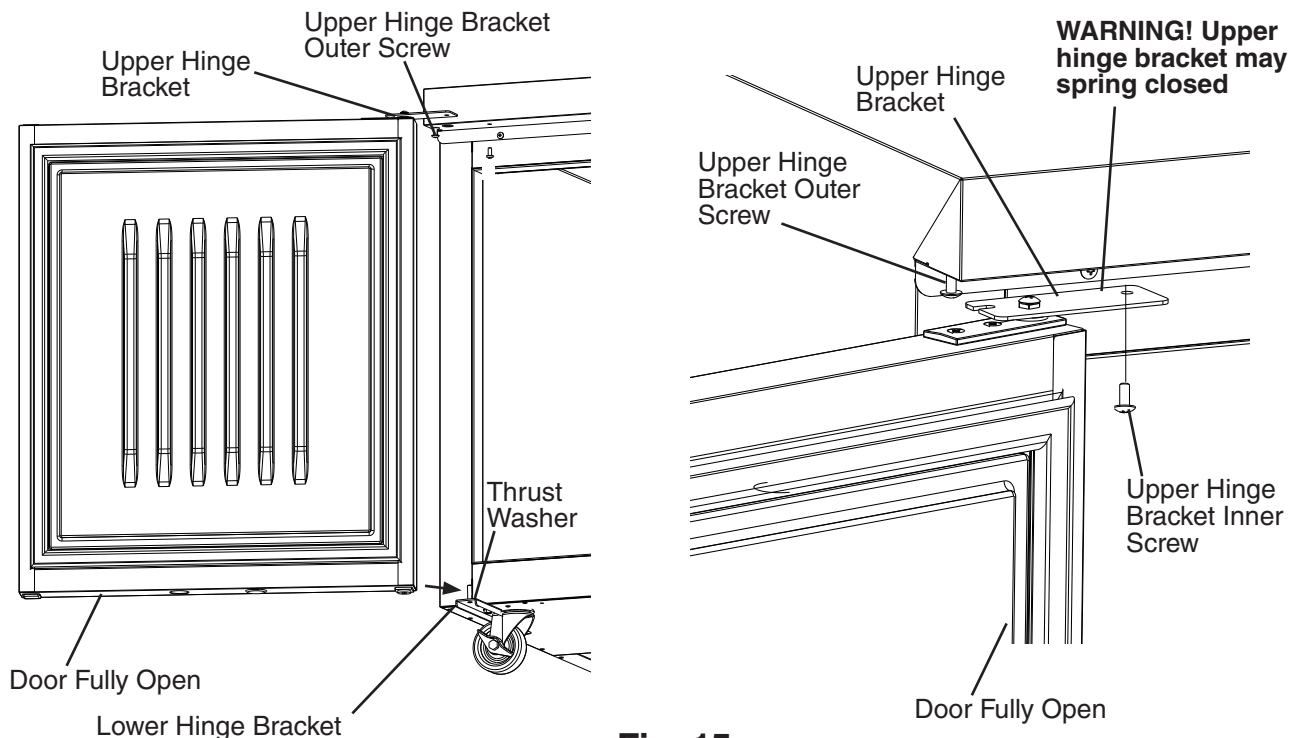

Fig. 15

- 16) Close the door and tighten the upper hinge bracket outer screw.
See Fig. 16.

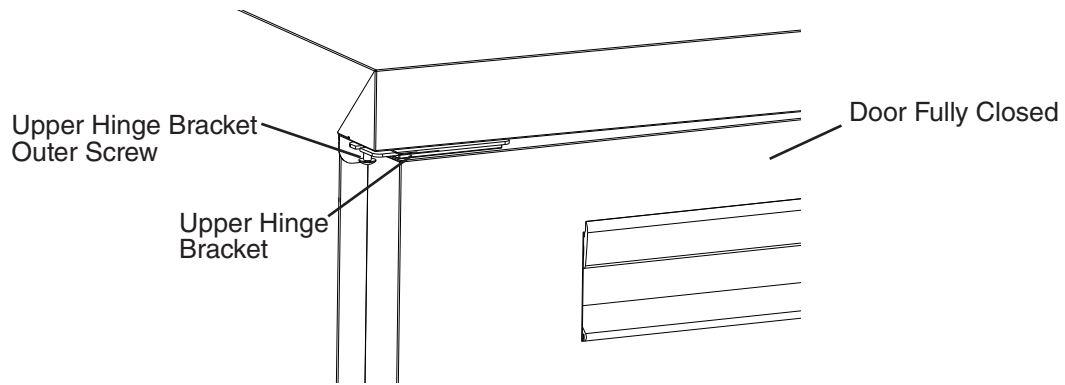

Fig. 16

- 17) Check the door operation to assure it opens and closes properly. Note: Hold door at 45° angle from closed position and release. Door should close on its own. If not, adjust hinge bracket.
- 18) Unlock the casters and move the appliance back into its original position. Lock the casters once in position, then plug the appliance back into the electrical outlet. Allow the appliance to cool down prior to putting product back in.

E. Door/Drawer Reversal

The appliance is provided with a cabinet design which, after being delivered to the installation location, permits changing of the drawer and door locations. To change the drawer and door locations, follow the steps below.

⚠ WARNING

- Wear proper PPE (personal protection equipment) when executing these procedures (safety glasses and gloves).
- Keep fingers away from edge of upper hinge bracket. Spring cartridge can cause the upper hinge bracket to move suddenly with extreme force.

Drawer and Drawer Cartridge Removal

- 1) Remove all items from the appliance. Make sure the appliance is unplugged from the electrical outlet. Move the appliance out for ease of access then lock the casters.
- 2) Remove the drawers. Pull the drawer out to its fully extended position. Open the safety clips (one on each side) by sliding them forward. See Fig. 17. Lift up on the handle slightly, then pull to disengage the drawer. Be sure to support the rear and front of the drawer while removing it and note which is the upper and lower drawer.

WARNING! Be sure to close the safety clips when reinstalling the drawer.

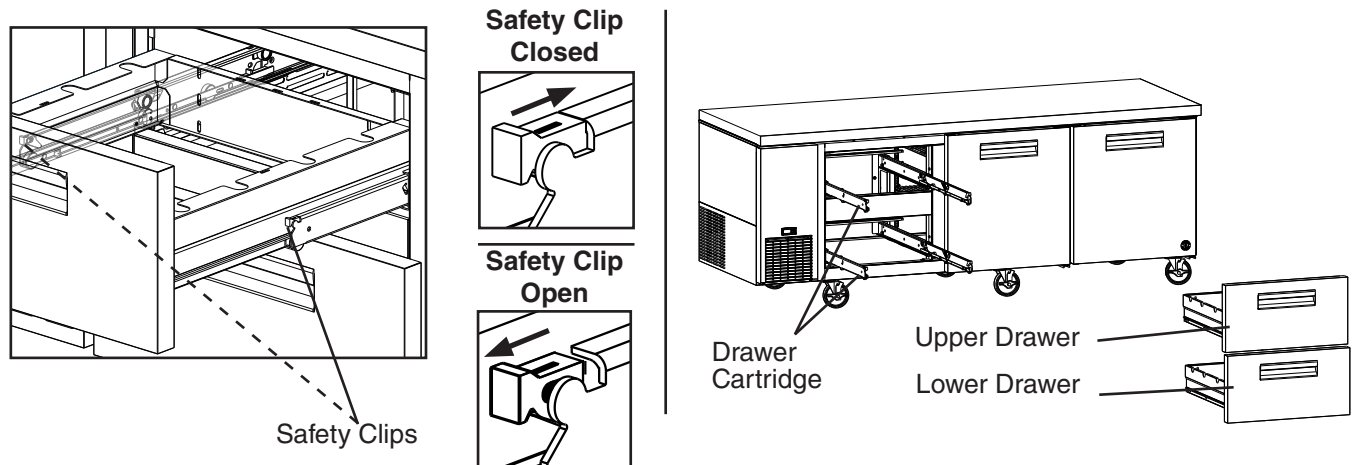

Fig. 17

- 3) Remove the 4 mullion screws, then cut the front mullion silicone loose and remove the mullion. See Fig. 18.

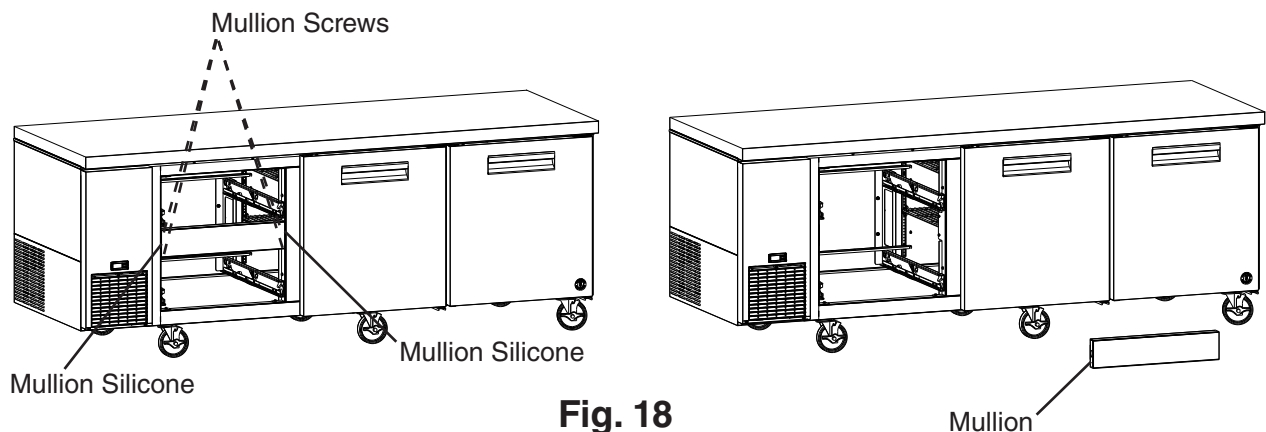

Fig. 18

- 4) Remove the 4 rear screws from the left and right drawer cartridge frames (2 per side). See Fig. 19.
- 5) Remove the 8 front screws from the left and right drawer cartridge frames (4 per side), then remove the cartridge frames from the appliance.

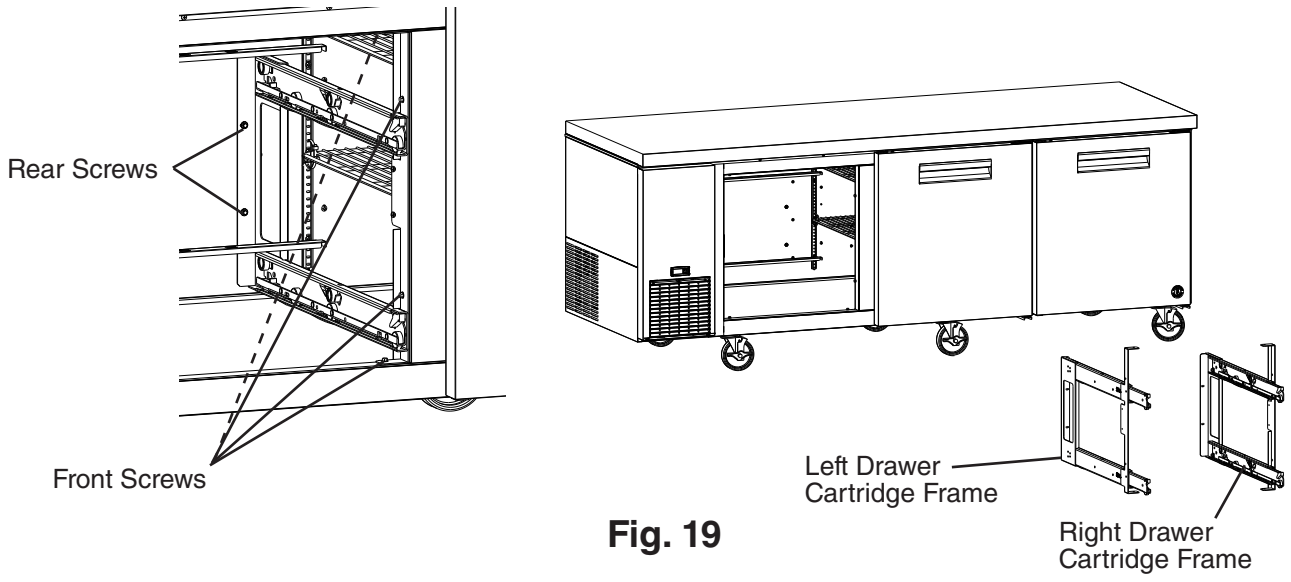

Fig. 19

Pilaster and Filler Screw Relocation

- 6) Remove the 12 pilaster filler screws from the current drawer section. See Fig. 20.

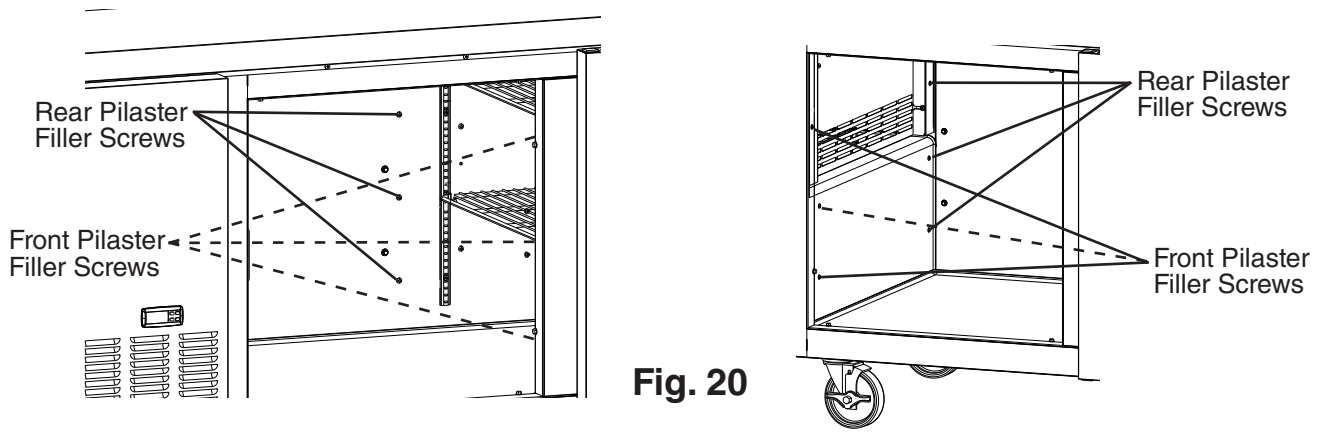

Fig. 20

- 7) Remove the shelves from the door section, then remove the pilasters and place and secure them in the new location (current drawer location). See Fig. 21. Note: Other than in a center location, outer pilasters mount on the side wall not the rear wall.
- 8) Place and secure the pilaster filler screws removed in step 6 into the new drawer location (current door location).

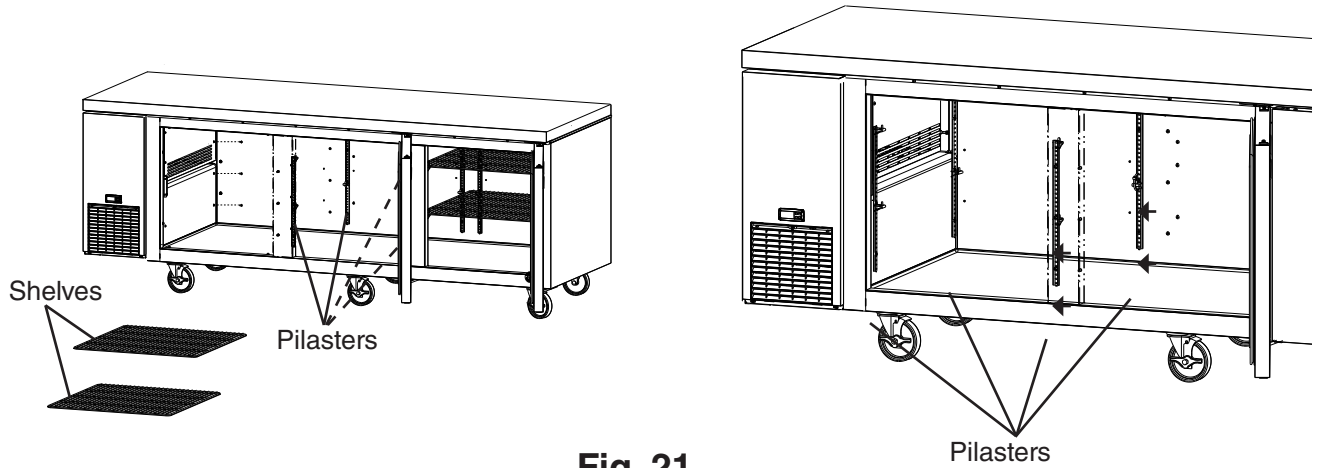

Fig. 21

- 9) Remove the drawer cartridge frame rear filler screws from the new location (current door location). Place the drawer cartridge frame filler screws in the new door location and tighten. Replace the shelves. See Fig. 22.

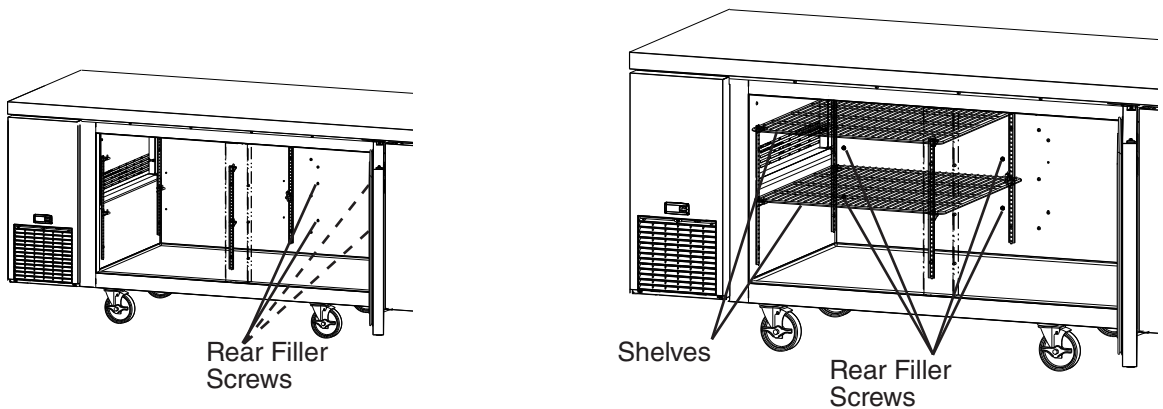

Fig. 22

Door Relocation

10) With the door closed, loosen, but do not remove, the upper hinge bracket outer screw. See Fig. 23. Next, open the door to the fully open position and remove the upper hinge bracket inner screw. See Fig. 24.

11) Slide the upper hinge bracket out from under the outer screw and remove the door. **WARNING! Keep away from upper hinge bracket. Upper hinge bracket may spring closed.**

12) Replace the upper hinge bracket inner screw in its original position and tighten, then tighten the upper hinge bracket outer screw.

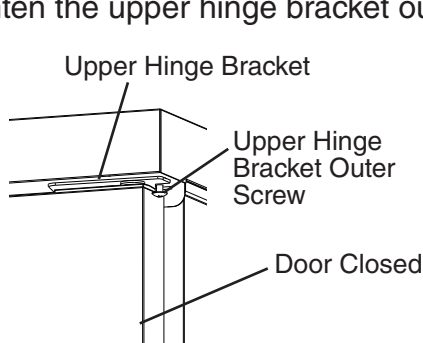

Fig. 23

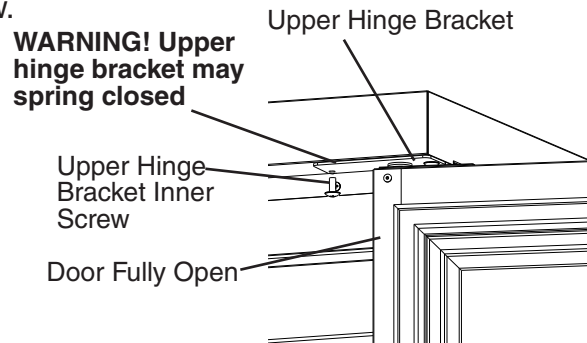

Fig. 24

13) Remove the lower hinge bracket. See Fig. 25. Be sure to leave the thrust washer in place.

14) Clear the foam from the lower hinge bracket mounting holes prior to securing the lower hinge bracket in its new location. Install the lower hinge bracket in its new location. Be sure the lower hinge bracket is pushed all the way in and the thrust washer is in its original position.

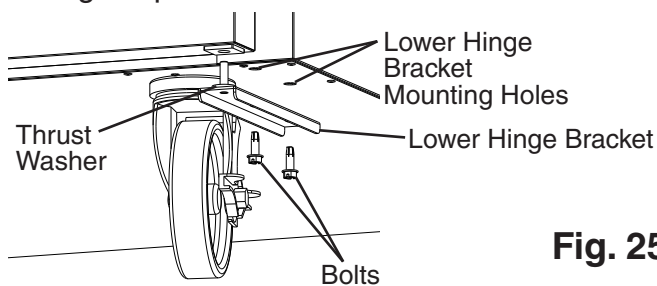
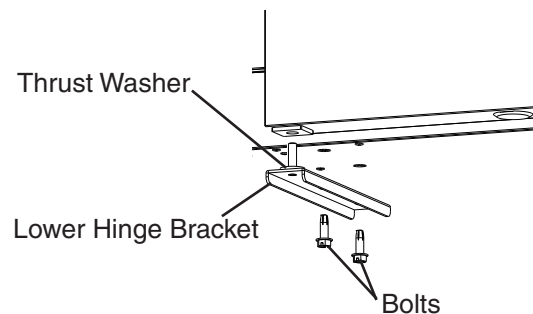

Fig. 25



15) Remove the black plastic filler cap located from the hole above where the spring cartridge screw will line up. Note: The black plastic filler cap is not reusable.

16) Remove the upper hinge bracket screws from the new location and apply Loctite Threadlocker Blue 242 or 243 to the threads. Next, start the upper hinge bracket outer screw into the appliance. Rotate a few threads into the appliance; do not tighten the screw. See Fig. 26.

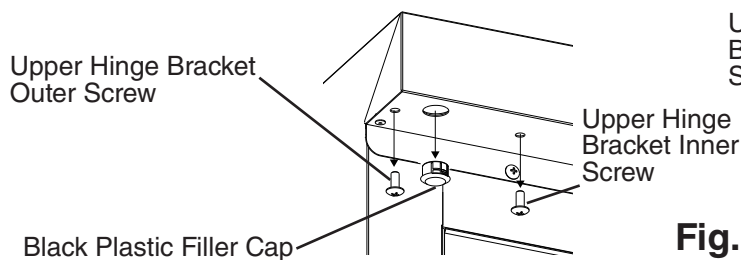
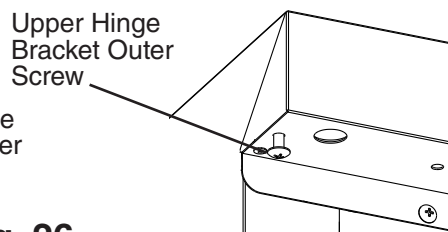

Fig. 26



- 17) Be sure the lower hinge bracket thrust washer is in place, then place the door on the lower hinge bracket in the fully open position. Slide the door upper hinge bracket outer slot onto the upper hinge bracket outer screw. See Fig. 27.
- 18) Install the upper hinge bracket inner screw and tighten.

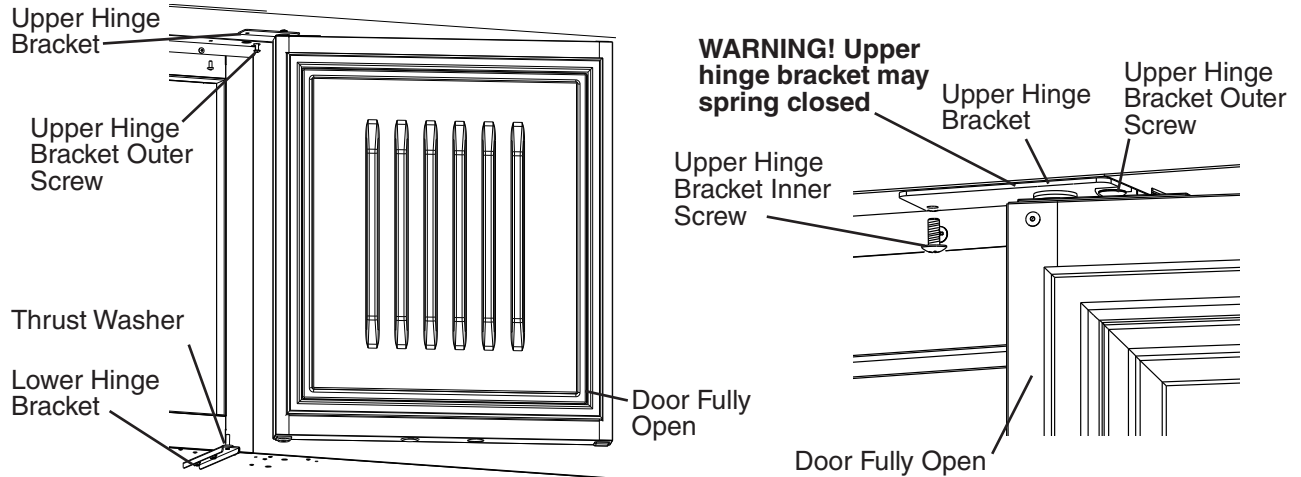

Fig. 27

- 19) Close the door and tighten the upper hinge bracket outer screw. See Fig. 28.

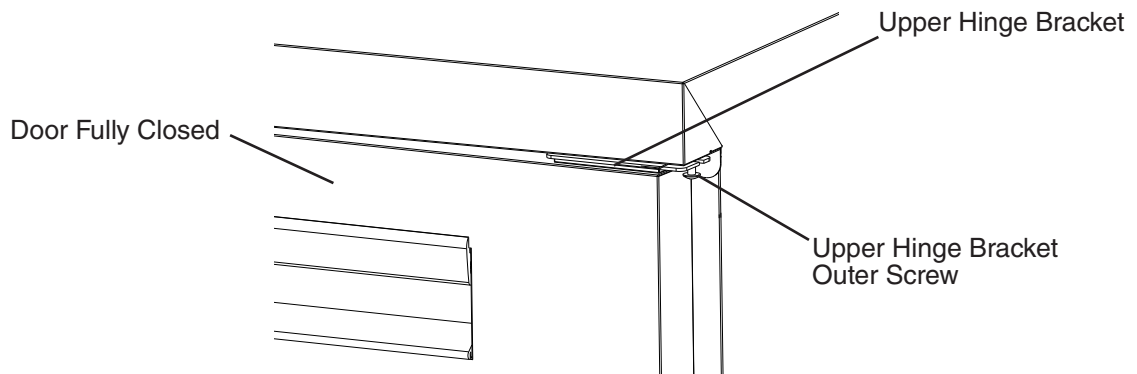
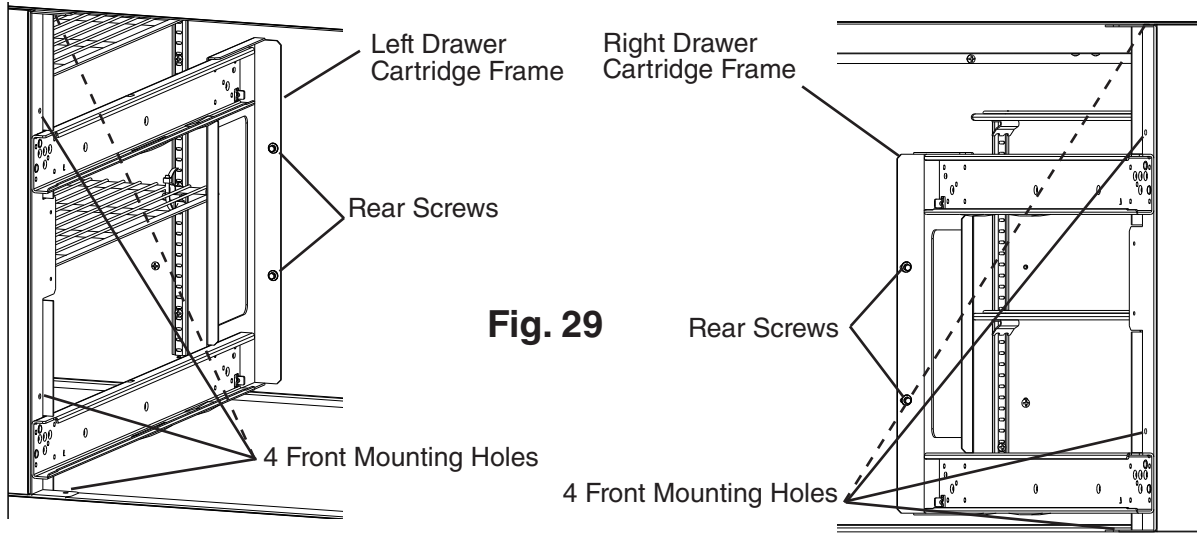

Fig. 28

- 20) Check the door operation to assure it opens and closes properly. Note: Hold door at 45° angle from closed position and release. Door should close on its own. If not, adjust hinge bracket.

- 21) Place the drawer cartridge frame removed in step 5, in place and secure to the rear panel with screws removed in step 4. See Fig. 29.
- 22) Using a 1/8" drill bit, drill pilot holes in all 4 front mounting holes. See Fig. 29.
- 23) Secure the drawer cartridge to the appliance with the screws removed in step 5.
- 24) Repeat steps 21 through 23 for the opposite side drawer cartridge frame.



- 25) Place the mullion in its correct position and secure with screws removed in step 3.
- 26) Place a bead of food grade silicone down the 2 outside vertical gaps between the mullion and appliance. See Fig. 30.

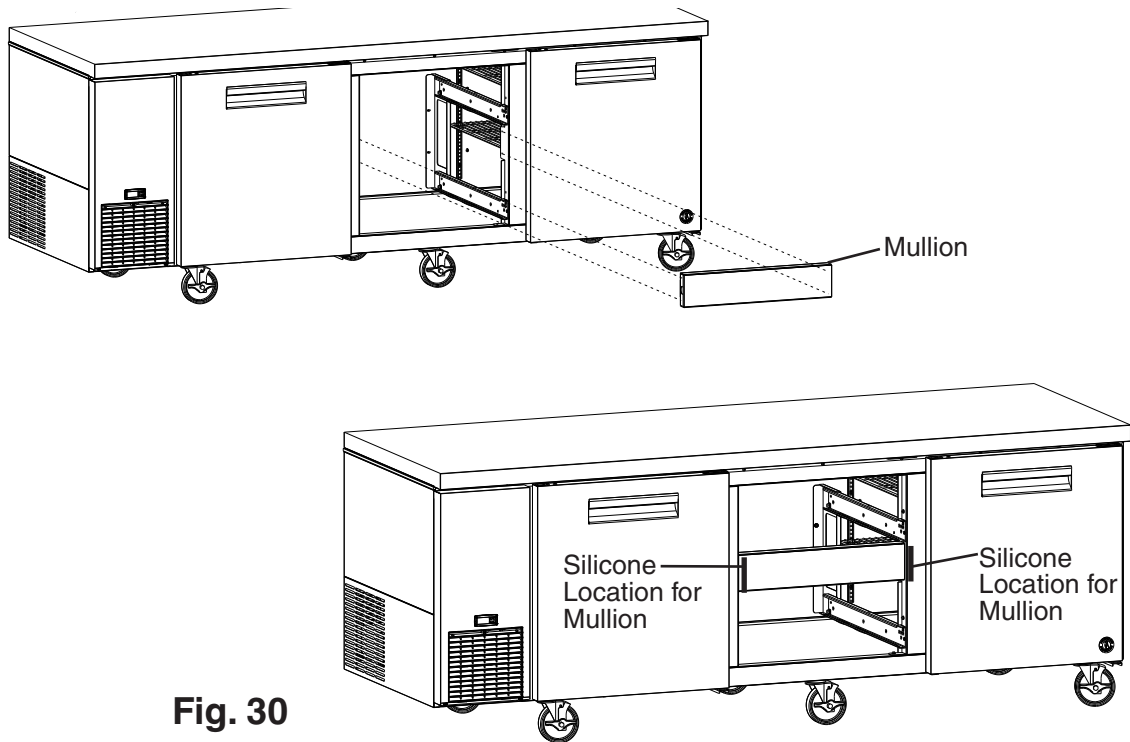

Fig. 30

- 27) Place the lower drawer in the lower drawer slides and the upper drawer in the upper drawer slides. See Fig. 31. **WARNING! Be sure to close the safety clips after reinstalling the drawer.**
- 28) Make sure all gaskets are making good contact. Using a flashlight, check that there are no openings around all gaskets.
- 29) Unlock the casters and move the appliance back into its original position. Lock the casters once in position, then plug the appliance back into the electrical outlet. Allow the appliance to cool down prior to putting product back in.

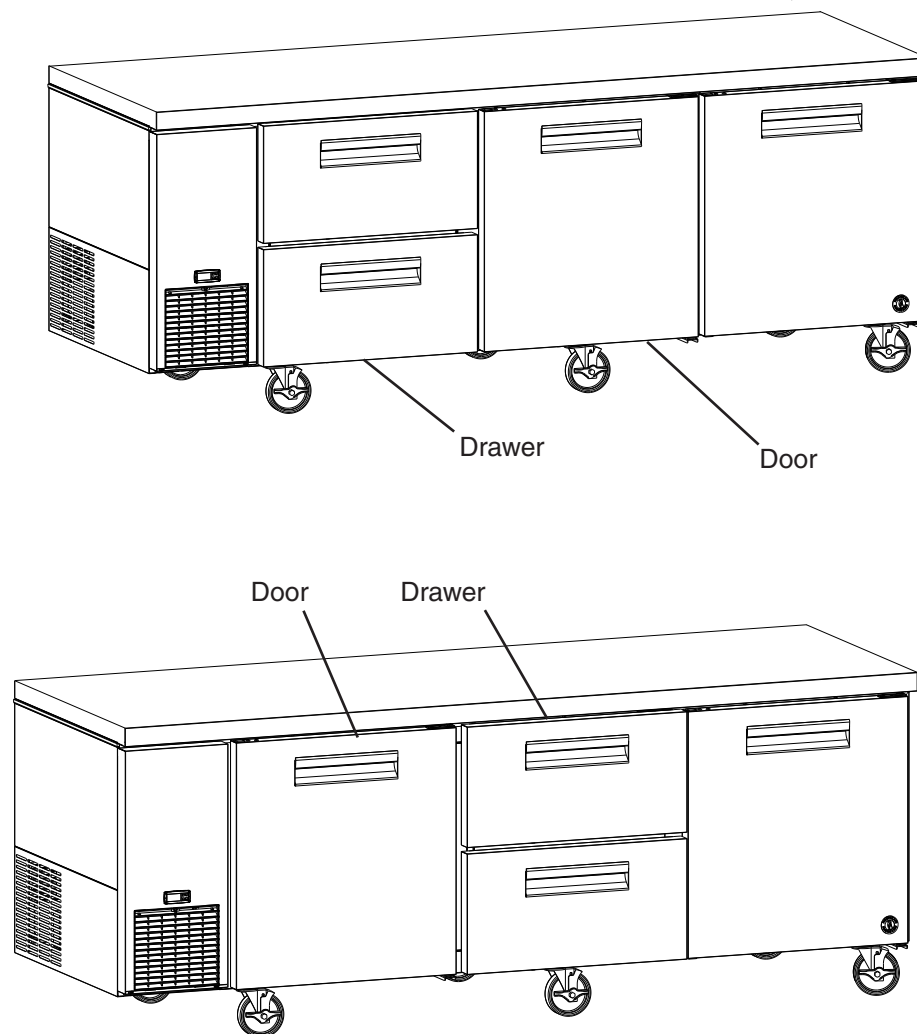



Fig. 31

F. Electrical Connection

WARNING

- Electrical connection must meet national, state, and local electrical code requirements. Failure to meet these code requirements could result in death, electric shock, serious injury, fire, or severe damage to equipment.
 - The appliance requires an independent power supply of proper capacity. See the nameplate for electrical specifications. Failure to use an independent power supply of proper capacity can result in a tripped breaker, blown fuse, damage to existing wiring, or component failure. This could lead to heat generation or fire.
 - **THE APPLIANCE MUST BE GROUNDED.** The appliance is equipped with a NEMA 5-15 three-prong grounding plug  to reduce the risk of potential shock hazards. It must be plugged into a properly grounded, independent 3-prong wall outlet. If the outlet is a 2-prong outlet, it is your personal responsibility to have a qualified electrician replace it with a properly grounded, independent 3-prong wall outlet. Do not remove the ground prong from the power cord and do not use an adapter plug. Failure to follow these instructions may result in death, electric shock, or fire.
 - To reduce the risk of electric shock, do not touch the plug with damp hands.
 - Do not use an extension cord.
 - Do not use an appliance with a damaged power cord. The power cord should not be altered, jerked, bundled, weighed down, pinched, or tangled. Such actions could result in electric shock or fire. To unplug the appliance, be sure to pull the plug, not the cord, and do not jerk the cord.
 - If the supply cord is damaged, it must be replaced by the manufacturer, its service agent, or similarly qualified persons in order to avoid a hazard. Upon replacement, the GREEN ground wire in the power cord must be connected to the designated grounding screw.
- Usually an electrical permit and services of a licensed electrician are required.
 - The maximum allowable voltage variation is ± 10 percent of the nameplate rating.

G. Final Checklist

- 1) Is the appliance level?
- 2) Have the casters been properly installed and have the front casters been locked?
- 3) Is the appliance in a site where the ambient temperature is constantly within 45°F to 100°F (7°C to 38°C)?
- 4) Have the shipping carton, tape, and packing material been removed from the appliance? Has the protective plastic film been removed from both the exterior panels?
- 5) Have the appliance and accessories been checked for shipping damage?
- 6) Are the factory-installed rear bumpers in place to ensure proper rear clearance?
- 7) Has the power supply voltage been checked or tested against the nameplate rating? Is the power supply a properly grounded, independent wall outlet? Does the electrical connection meet all national, state, and local code and regulation requirements.
- 8) Have the refrigerant lines been checked to make sure they do not rub or touch other lines or surfaces? Has the condenser fan blade been checked to make sure it turns freely? Is the compressor securely attached?
- 9) Have the shelves been adjusted to the desired height?
- 10) Has the end user been given the instruction manual, and instructed on how to operate the appliance and the importance of the recommended periodic maintenance?
- 11) Has the end user been given the name and telephone number of an authorized service agent?
- 12) Has the warranty card been filled out and forwarded to the factory for warranty registration?

III. Operating Instructions



R-290 Class A3 Flammable Refrigerant Used

⚠ DANGER

Risk of Fire or Explosion. Flammable Refrigerant Used.

- Be sure to follow all Important Safety Information located at the beginning of this manual.
- Failure to install, operate, and maintain the appliance in accordance with this manual will adversely affect safety, performance, component life, and warranty coverage.
- Keep clear of obstruction all ventilation openings in the appliance enclosure or in the structure for building-in.

Risque D'Incendie ou D'Explosion. Fluide Frigorigène Inflammable Utilisé.

- Veuillez à respecter toutes les consignes de sécurité importantes figurant au début de ce manuel.
- Le fait de ne pas installer, utiliser et entretenir l'appareil conformément à ce manuel aura des conséquences négatives sur la sécurité, les performances, la durée de vie des composants et la couverture de la garantie.
- Ne pas obstruer les ouvertures de ventilation dans l'enceinte de l'appareil ou dans la structure d'encastrement.

A. Important Notes About Usage

⚠ WARNING

- Failure to install, operate, and maintain the appliance in accordance with this manual may adversely affect safety, performance, component life, and warranty coverage.
- Only qualified service technicians should install and service the appliance.
- To reduce the risk of electric shock, do not touch the plug with damp hands.
- Do not use combustible spray or place volatile or flammable substances in or near the appliance. They might catch fire.
- Do not splash, pour, or spray water directly onto or into the appliance. This might cause short circuit, electric shock, corrosion, or failure.
- Food storage and handling must comply with applicable codes and regulations.
- Keep the area around the appliance clean. Dirt, dust, or insects in the appliance could cause harm to individuals or damage to the equipment.
- The appliance is designed only for temporary storage of food. Employ sanitary methods. Use for any other purposes (for example, storage of chemicals or medical supplies such as vaccine and serum) could cause deterioration of stored items.
- Do not store items near air outlets. Otherwise, items may freeze up and crack or break causing a risk of injury or contamination of other food.

⚠ WARNING continued

- Do not put warm or hot foods in the cabinet. Let them cool first, or they will raise the cabinet temperature and could deteriorate other foods in the cabinet or overload the appliance.
- All foods should be wrapped in plastic film or stored in sealed containers. Otherwise foods may dry up, pass their smells onto other foods, cause frost to develop, result in poor appliance performance, or increase the likelihood of cross-contamination. Certain dressings and food ingredients, if not stored in sealed containers, may accelerate corrosion of the evaporator, resulting in failure.
- Do not block air inlets or outlets, otherwise cooling performance may be reduced.
- Do not tightly pack the cabinet. Allow some space between items to ensure good air flow. Also allow space between items and interior surfaces.
- Do not place any product on the floor of the cabinet. All product must be placed on properly installed shelves.
- Do not throw anything onto the shelves or load any single shelf with more than 120 lb. (54.5 kg) of product. They might fall off and cause injury.
- Do not load any single drawer with more than 75 lb. (34 kg) of product. Depending on the weight of product in the drawers, secure the unit as necessary to prevent it from overturning. Do not open more than one drawer at a time.
- Open and close the doors with care. Opening the doors too quickly or forcefully may cause injury or damage to the appliance or surrounding equipment.
- Be careful not to pinch fingers when opening and closing the doors. Be careful when opening and closing the doors when children are in the area.
- The appliance is not intended for use by persons (including children) with reduced physical, sensory, or mental capabilities, or lack of experience and knowledge, unless they have been given supervision or instruction concerning use of the appliance by a person responsible for their safety.
- Children should be properly supervised around the appliance.
- Do not climb, stand, or hang on the appliance or doors or allow children or animals to do so. Do not climb into the appliance or allow children or animals to do so. Death or serious injury could occur or the appliance could be damaged.

NOTICE

- Protect the floor when moving the appliance to prevent damage to the floor.
- Keep ventilation openings, in the appliance enclosure or in the built-in structure, clear of obstruction. Blockage of airflow could negatively affect performance and damage the appliance.
- Do not allow the appliance to bear any outside weight.
- To prevent deformation or cracks, do not spray insecticide onto the plastic parts or let them come into contact with oil.
- To avoid damage to the gasket, use only the door handle when opening and closing.
- Do not leave the doors open.
- The factory-installed rear bumpers must be in place to ensure proper rear clearance. Blockage of airflow could negatively affect performance and damage the appliance.

B. Startup

⚠ WARNING

- All parts are factory-adjusted. Improper adjustments may adversely affect safety, performance, component life, and warranty coverage.
- Allow the appliance to cool down prior to loading it with food products.

- 1) Plug the appliance into the electrical outlet. At startup, there is a slight delay before the compressor starts. If the temperature is not displayed, press the "U" button for 1 sec.
WARNING! To reduce the risk of electric shock, do not touch the plug with damp hands.

C. Controls and Adjustments

1. Temperature Display

The cabinet temperature is displayed on the control module. See Fig. 32.

The factory default display setting is in °F.

To convert from °F to °C, see "III.C.3. Changing the Temperature Display Scale (°F or °C)."

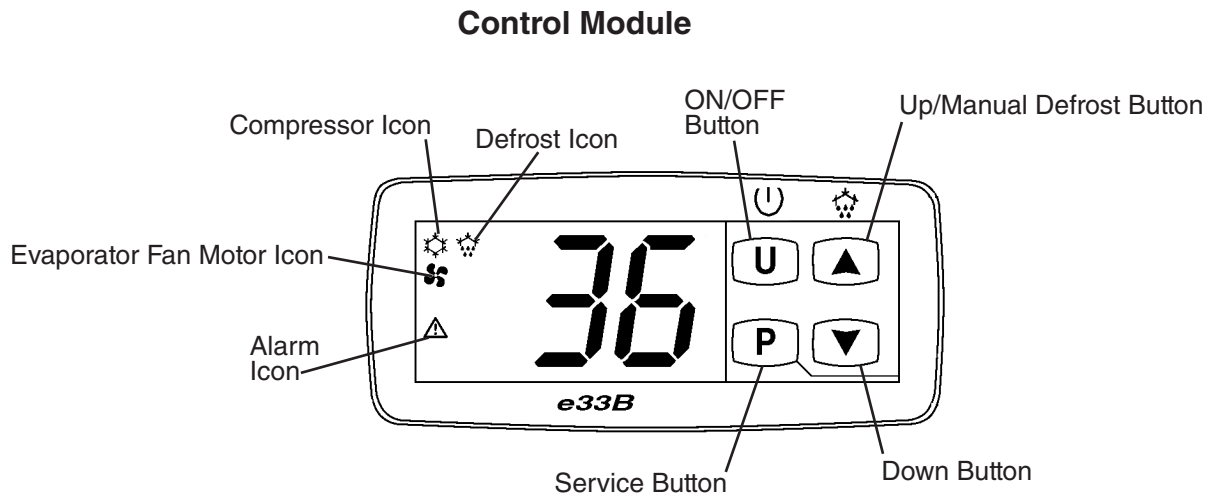

Fig. 32

2. Adjusting the Temperature Setpoint

The temperature setpoint is used to adjust the amount of cooling for the cabinet.

Note: The temperature differential for the compressor to turn on or off is:

Refrigerator: $\pm 2.7^{\circ}\text{F}$ ($\pm 1.5^{\circ}\text{C}$) of the temperature setpoint.

Freezer: $\pm 2.2^{\circ}\text{F}$ ($\pm 1.2^{\circ}\text{C}$) of the temperature setpoint.

For example, a refrigerator temperature setpoint of 34°F (1.1°C), the compressor turns on at 36.7°F (2.6°C) and the compressor turns off at 31.3°F (-0.4°C). If necessary, adjust the temperature setpoint temperature as follows:

- a) To change the temperature setpoint, press the down button briefly and then release. SP1 flashes for a few seconds, then the current temperature setpoint appears. Press the up or down button until the desired value is displayed. After 10 seconds or the "P" button is pressed, the display returns to the current cabinet temperature and the temperature setpoint is saved. **NOTICE! Do not adjust the temperature setpoint more than 2°F (1°C) at a time. Allow the temperature to stabilize for a minimum of 8 hours before making further temperature setpoint adjustments.**

Model	Temperature Setpoint Range	Factory Default Temperature Setting
Refrigerator	28°F to 45°F (-2.2°C to 7.2°C)	36°F (2.2°C)
Freezer	-12°F to 10°F (-24.4°C to -12.2°C)	2.0°F (-16.7°C)

3. Cabinet Temperature Display Scale ($^{\circ}\text{F}$ or $^{\circ}\text{C}$)

There are 4 temperature display settings from which to choose.

The factory temperature display default is F0 for $^{\circ}\text{F}$ whole number.

For a whole number temperature display scale value, select F0 or C0.

For a temperature display scale value to one decimal point, select F1 or C1.

Display Scale	Temperature Display Style
F0 - Factory Default	36°F
C0	2°C
F1	36.0°F
C1	2.2°C





To change the temperature display scale value, follow the steps below:

- 1) Press the "U" and "P" buttons together for 5 seconds. $\dots\text{uP}$ is displayed.
- 2) Press the "P" button. The current display setting (F0, F1, C0, or C1) and $\dots\text{uP}$ start flashing.
- 3) Press the up or down button until the desired temperature display style is displayed.
- 4) Press the "P" button to save the selection. $\dots\text{uP}$ is displayed. To return to normal display mode, press and hold the "U" button for 5 sec. Display returns to normal display mode. If no other button is pressed after pressing the "P" button, 25 sec. later, display returns to normal display mode.

Note: If no selection is saved within 30 seconds, the display returns to normal mode and the temperature display scale remains unchanged.

D. Cabinet Control Display Icons

Control module icons inform you of energized components and if the appliance is in alarm.

Control Module Icons	
Icon	Meaning
	Compressor Flashing: Refrigerator: Compressor waiting for 2-min. compressor delay timer to terminate. Freezer: Compressor waiting for 3.5-min. compressor delay timer to terminate. Solid: Compressor energized.
	Defrost Flashing: Drip Time (compressor delay) Solid: Appliance is in defrost cycle. See "II.E. Defrost" for details.
	Evaporator Fan Motor Flashing: Refrigerator: Evaporator fan motor waiting for 2-min. evaporator fan motor delay timer to terminate. Freezer: Evaporator fan motor waiting for 3.5-min. evaporator fan motor delay timer to terminate. Solid: Evaporator fan motor energized.
	Alarm Appliance is in alarm. See "II.F. Alarm Safeties" for details.

E. Defrost

⚠ DANGER

Risk of Fire or Explosion. Flammable Refrigerant Used.

- Do not use mechanical devices or other means to accelerate the defrosting process, other than those recommended by the manufacturer.
- Do not puncture refrigerant tubing. Risk of fire or explosion due to puncture of refrigerant tubing; follow handling instructions carefully.

Risque De Feu Ou D'Explosion. Fluide Frigorigène Inflammable Utilisé.

- Ne pas utiliser d'appareils mécaniques pour dégivrer le réfrigérateur.
- Ne pas perforer la tubulure contenant le frigorigène. Risque de feu ou d'explosion si la tubulure contenant le frigorigène est perforée; suivre les instructions de manutention avec soin.

1. Refrigerators

Off-Cycle Defrost: Refrigerators defrost naturally between run cycles and have a temperature or time initiated defrost cycle.

Note: There is a 1-hr. defrost lock-out after a defrost cycle terminates. This may be bypassed by initiating a manual defrost or unplugging and plugging back in to the electrical outlet.

- Temperature Initiated: When the defrost thermistor is at or below -4°F (-20°C), defrost starts.
- Time Initiated:
 - a) Cumulative Compressor Run Time: Once the 6-hr. Cumulative Compressor Run Timer terminates, defrost starts.
 - b) Continuous Compressor Run Time: Once the 4hr. Continuous Compressor Run Timer terminates, defrost starts.

The maximum defrost time is 1 hr.

- When defrost initiates, the maximum 1-hr. defrost timer starts. Compressor and condenser fan motor de-energize. Evaporator fan motor remains energized.
- When the defrost thermistor reaches 45°F (7.2°C), or the maximum 1-hr. defrost timer terminates, defrost terminates. Evaporator fan motor remains energized and compressor and condenser fan motor energize.

2. Freezers

Heated Defrost: Freezers utilize a temperature or time initiated heated defrost.

Note: There is a 1-hr. defrost lock-out after a defrost cycle terminates. This may be bypassed by initiating a manual defrost or unplugging and plugging back in to the electrical outlet.

- Temperature Initiated: When the defrost thermistor is at or below -32°F (-35.5°C), defrost starts.
- Time Initiated:
 - a) Cumulative Compressor Run Time: Once the 12-hr. Cumulative Compressor Run Timer terminates, defrost starts.
 - b) Continuous Compressor Run Time: Once the 4hr. Continuous Compressor Run Timer terminates, defrost starts.

The maximum defrost time is 1 hr.

- When defrost initiates, the maximum 1-hr. defrost timer starts. Compressor and condenser fan motor de-energize. Evaporator fan motor remains energized.
- When the defrost thermistor reaches 55°F (12.7°C), or the maximum 1-hr. defrost timer terminates, defrost terminates. Evaporator fan motor remains energized and compressor and condenser fan motor energize.

3. Defrost Display

- a) **Refrigerator Display:** During defrost "dEF" is displayed. The compressor icon turns off and the evaporator fan motor icon continues. Once defrost termination temperature is achieved or the maximum timer times out, defrost terminates. The compressor icon turns on, the evaporator fan motor icon continues and PdF is displayed. PdF continues until the cabinet temperature achieves 2.7°F (1.5°C) above temperature setpoint or the 15-min. timer terminates. Once 2.7°F (1.5°C) above temperature setpoint is achieved or the 15-min. timer terminates, the cabinet temperature returns to display.
- b) **Freezer Display:** During defrost "dEF" is displayed. The compressor and evaporator fan motor icons turn off. Once defrost termination temperature is achieved or the maximum timer times out, defrost terminates. The defrost icon starts flashing, PdF is displayed, and the 3-min. drip timer starts. Once the 3-min. drip timer terminates, the defrost icon turns off, the compressor and evaporator fan motor icons turn on, and PdF continues. PdF continues until the cabinet temperature achieves 2.2°F (1.2°C) above temperature setpoint or 15-min. timer terminates. Once 2.2°F (1.2°C) above temperature setpoint is achieved or 15-min. timer terminates, the cabinet temperature returns to display.

4. Defrost Termination

Defrost Termination Temperature:

Refrigerator: 45°F (7.2°C)

Freezer: 55°F (12.7°C)

Example: After the refrigerator defrost thermistor warms to 45°F (7.2°C), defrost terminates.

5. Manual Defrost

To initiate a manual defrost, press and hold the up button for 5 seconds.

To terminate a defrost, press and hold the up button for 5 seconds. Note: Manual defrost only initiates when evaporator temperature (defrost thermistor) is at or below 45°F (7.2°C) for refrigerators and 56°F (13.3°C) for freezers.

F. Cabinet Control Alarm Safeties

Alarm signals are designed to protect the appliance and food product. These alarms give information or warnings in the event the appliance is operating out of acceptable parameters. Should one of the alarms occur, follow the instructions in the table below to address the alarm. The alarm code and alarm icon flash with audible alarm.

Alarm Signals		
Alarm Code	Problem	Corrective Action/Reset Details
(-)E1	Cabinet Thermistor Malfunction Alarm Cabinet thermistor has failed.	Call a qualified service technician. Steady tone. To silence the alarm, press and release any button. Refrigerator: Appliance cycles 4 min. on, 6 min. off. Freezer: Appliance cycles 6 min. on, 3 min. off. -E1 - Cabinet thermistor out of place or open. E1 - Cabinet thermistor shorted.
(-)E2	Defrost Thermistor Malfunction Alarm Defrost thermistor has failed.	Call a qualified service technician. Steady tone. To silence the alarm, press and release any button. Appliance cycles on and off with cabinet thermistor. Refrigerator: Defrost cycles for 20 min. every 12 hrs. Freezer: Defrost cycles for 15 min. every 5 hrs. -E2 - Defrost thermistor out of place or open E2 - Defrost thermistor shorted.
Hi	High Temperature Alarm Refrigerator: Cabinet temperature has remained above 53°F (11.6°C) for more than 1 hour. Freezer: Cabinet temperature has remained above 32°F (0°C) for more than 1 hour.	If obvious corrections such as closing drawers and cleaning the air filter and/or condenser do not bring temperature back in range, call a qualified service technician. Steady tone. To silence the alarm and clear "Hi" from the display, press and release any button. The alarm icon stays on. Automatically resets when temperature returns to normal.
Lo	Low Temperature Alarm Refrigerator: Cabinet temperature has remained below 20°F (-6.7°C) for more than 1 hour. Freezer: Cabinet temperature has remained below -30°F (-34.4°C) for more than 1 hour.	If obvious corrections do not bring the temperature back in range, call a qualified service technician. Steady tone. To silence the alarm and clear "Lo" from the display, press and release any button. The alarm icon stays on. Automatically resets when temperature returns to normal.
UHi	High Voltage Alarm (140VAC ± 5% or more)	The compressor de-energizes if voltage protection operates.
ULo	Low Voltage Alarm (100VAC ± 5% or less)	The voltage safeties automatically reset when voltage is corrected.

G. Food Storage

WARNING

- Storage of foods should follow all local codes and regulations.
- The appliance is designed only for temporary storage of food. Employ sanitary methods. Use for any other purposes (for example, storage of chemicals or medical supplies such as vaccine and serum) could cause deterioration of stored items.
- Do not block air inlets or outlets, otherwise cooling performance may be reduced.
- Do not tightly pack the cabinet. Allow some space between items to ensure good air flow. Also allow space between items and interior surfaces.
- Do not put warm or hot foods in the cabinet. Let them cool first, or they will raise the cabinet temperature and could deteriorate other foods in the cabinet or overload the appliance.
- All foods in the cabinet should be wrapped in plastic film or stored in sealed containers. Otherwise foods may dry up, pass their smells onto other foods, cause frost to develop, result in poor appliance performance, or increase the likelihood of cross-contamination. Certain dressings and food ingredients, if not stored in sealed containers, may accelerate corrosion of the evaporator, resulting in failure.
- Do not store items near air outlets in the cabinet. Otherwise, items may freeze up and crack or break causing a risk of injury or contamination of other food.

H. Safety Devices

1. Compressor External Protector

If combined temperature/amperage value is above the limit specified by the compressor manufacturer, the compressor protector operates independently to turn off the compressor. The compressor protector de-energizes the compressor until the temperature/amperage value returns to an acceptable level.

2. Short-Cycle Protection

There is a minimum off-time and on-time for the compressor.

Refrigerator: 2-min.

Freezer: 3.5-min.

Note: Time may vary with compressor overload.

I. Cooling Performance

Be sure the appliance is properly installed and located for optimum cooling performance. If cooling performance is not at its optimum level, check the following items:

- Doors/drawers opened too often.
- Doors/drawers left open. Close.
- Cabinet too tightly packed or air inlets/outlets blocked. Allow some space between items to ensure good air flow.
- Warm or hot foods inside. Take them out until they cool down more.
- Ambient temperature too high. Avoid installation near high heat producing equipment or exposure to direct sunlight.
- Temperature setpoint not cold enough. Adjust to a colder setting. See "III.C. Controls and Adjustments" for details.
- Appliance in defrost cycle. The cabinet temperature may rise temporarily during the defrost cycle, but this will not affect the food inside.

J. Cabinet Condensation

In the event condensation develops on the cabinet exterior, check the following items:

- Doors/drawers left open. Close.
- Ambient humidity too high. In high humidity areas it may be necessary to wipe off the cabinet frame occasionally.

IV. Maintenance

The appliance must be maintained in accordance with the instruction manual and labels provided. Consult with your local Hoshizaki Certified Service Representative about maintenance service.

⚠ WARNING

- Press and hold the "U" button for 1 sec. to turn the appliance off. Unplug the appliance before performing maintenance to prevent electric shock or injury by moving parts. To reduce the risk of electric shock, do not touch the plug with damp hands.
- Risk of electric shock. Appliance in the off position does not de-energize all loads. Use extreme caution and exercise safe electrical practices.
- Before performing maintenance, move all foods into another clean refrigerator.
- Before performing maintenance, disconnect any cooking equipment on the appliance top and allow to cool.

A. Maintenance Schedule

The maintenance schedule below is a guideline. More frequent maintenance may be required depending on the appliance's environment, and local sanitation regulations.

Maintenance Schedule		
Frequency	Area	Task
Bi-Weekly	Air Filters	Inspect. Wash with warm water and neutral cleaner if dirty.
Bi-Yearly	Condenser	Inspect. Clean if necessary by using a brush or vacuum cleaner. More frequent cleaning may be required depending on location.

Air Filter and Condenser Access:

Remove the screw securing the louver to the appliance, then press down on the louver upper tab and remove the louver to access the air filter and condenser. See Fig. 33.

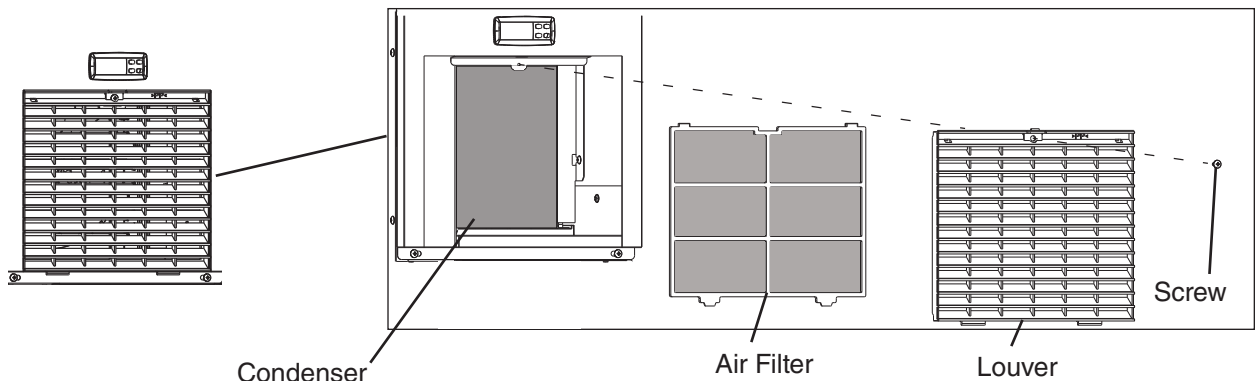

Fig. 33

B. Cleaning

⚠ WARNING

- Press and hold the "U" button for 1 sec. to turn the appliance off. Unplug the appliance before cleaning to prevent electric shock by unexpected entrance of water into the appliance or injury by moving parts. To reduce the risk of electric shock, do not touch the plug with damp hands.
- Risk of electric shock. Appliance in the off position does not de-energize all loads. Use extreme caution and exercise safe electrical practices.
- Before cleaning the appliance, move all foods into another clean refrigerator.
- Before cleaning the appliance, disconnect any cooking equipment on the appliance top and allow to cool.
- Do not splash, pour, or spray water directly onto or into the appliance. This might cause short circuit, electric shock, corrosion, or failure.
- Carefully follow instructions provided with cleaning and sanitizing products.

NOTICE

- To prevent damage to the plastic surfaces, do not use the following: hot water, thinner, benzine, alcohol, petroleum, soap powder, polishing powder, alkaline cleaner, acid, scouring pad and especially those strong cleaners for use on a ventilating fan or a cooking range.
- To prevent corrosion and damage to stainless steel surfaces, use only products formulated for use on stainless steel appliances. Do not use steel wool, abrasive products, or products containing sodium hypochlorite (chlorine bleach).
- Use a clean cloth for cleaning.

1. Exterior

Wipe the exterior occasionally with a clean, soft cloth. Use a damp cloth containing a neutral cleaner to wipe off oil or dirt buildup. Clean any rust colored spots using a non-abrasive cleanser.

2. Interior

Spills should be wiped up promptly to avoid unpleasant odors. The cabinet interior should be cleaned periodically with a mild soap or detergent and warm water.

3. Door/Drawer Gaskets

Door and drawer gaskets should be cleaned regularly with mild soap and warm water to remove dirt and grease.

4. Drawers

Wipe the exterior occasionally with a clean, soft cloth. Use a damp cloth containing a neutral cleaner to wipe off food, oil, or dirt buildup. Clean any rust colored spots using a non-abrasive cleanser. Spills should be wiped up promptly to avoid unpleasant odors. The drawer interior should be cleaned periodically with a mild soap or detergent and warm water. Drawers and drawer slides are removable.

- **To remove a drawer:** Remove all items from the drawer. Pull the drawer out to its fully extended position. Open the safety clips (one on each side) by sliding them forward. See Fig. 34. Lift up on the handle slightly, then pull to disengage the drawer. Be sure to support the rear and front of the drawer while removing it. **WARNING! Be sure to close the safety clips when reinstalling the drawer.**
- **To remove a drawer slide (center slide containing rollers):** Open the stop levers (one on each side) by sliding them to the rear. See Fig. 35. Lift up on the drawer slide slightly, then pull to disengage the drawer slide. **WARNING! Be sure to close the stop levers when reinstalling the drawer.** Drawer slides do not require lubrication, but drawer slides should be kept clean and free of food.
Note: Drawer slides are dishwasher safe.

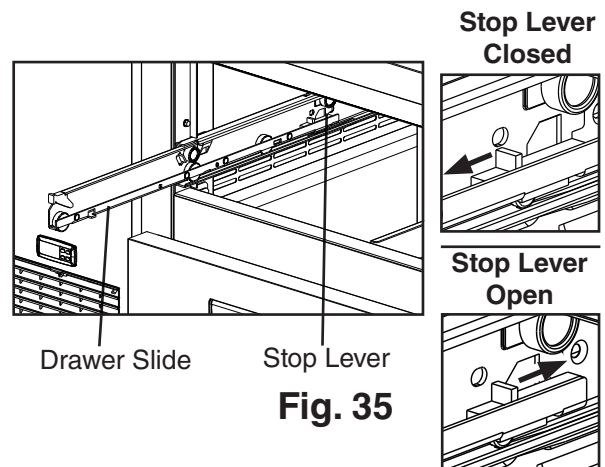
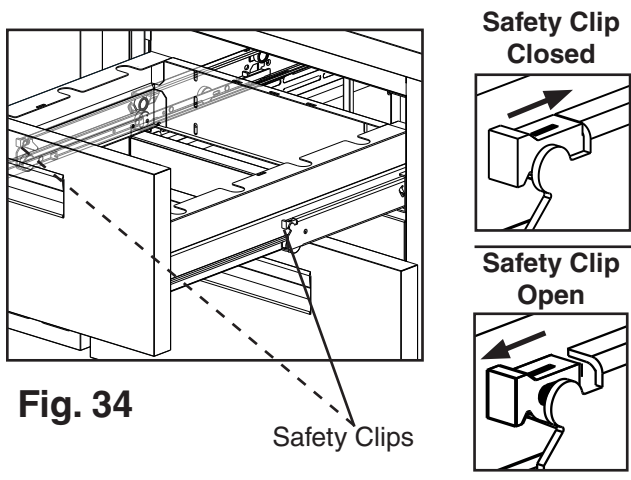

V. Prepare the Appliance for Periods of Non-Use

When shutting down the appliance for more than one week, follow the instructions below.

⚠ WARNING

- | |
|---|
| <ul style="list-style-type: none">• When preparing the appliance for long storage, prevent the doors or drawers from closing to reduce the risk of children getting trapped.• Risk of electric shock. Appliance in the off position does not de-energize all loads. Use extreme caution and exercise safe electrical practices.• To reduce the risk of electric shock, do not touch the plug with damp hands. |
|---|

NOTICE

When preparing the appliance for long storage, clean the appliance. See "IV.B. Cleaning" for details.
--

- 1) Before shutting down the appliance, move all foods into another clean refrigerator.
- 2) Press and hold the "U" button for 1 sec. to turn the appliance off. Unplug the appliance.
WARNING! To reduce the risk of electric shock, do not touch the plug with damp hands.
- 3) **WARNING! Prevent the drawers from closing to reduce the risk of children getting trapped.**

VI. Decommissioning and Disposal



R-290 Class A3 Flammable Refrigerant Used

⚠ DANGER

Risk of Fire or Explosion. Flammable Refrigerant Used.

- Only qualified service technicians should install and service the appliance.
- Follow handling instructions carefully in compliance with national regulations.
- Dispose of properly in accordance with federal or local regulations.
- Do not puncture refrigerant tubing. Risk of fire or explosion due to puncture of refrigerant tubing; follow handling instructions carefully.
- Be sure to follow the full Decommissioning and Disposal information located in the Service Manual for this model. The Service Manual is available at www.hoshizakiamerica.com.

Risque D'Incendie ou D'Explosion. Fluide Frigorigène Inflammable Utilisé.

- Seuls des techniciens de service qualifiés doivent installer et entretenir l'appareil.
- Suivre attentivement les instructions de manutention conformément aux règlements nationaux.
- Mettre au rebut conformément aux conformément aux règlements fédéraux ou locaux.
- Ne pas perforer la conduite de fluide frigorigène. Risque d'incendie ou d'explosion en cas de perforation d'une canalisation de fluide frigorigène; suivez attentivement les instructions de manutention.
- Veiller à respecter l'ensemble des informations relatives à la mise hors service et à la mise au rebut figurant dans le manuel d'entretien de ce modèle. Le manuel d'entretien est disponible à l'adresse suivante: www.hoshizakiamerica.com.

HOSHIZAKI AMERICA, INC.

618 Hwy. 74 South, Peachtree City, GA 30269 USA (P) 770.487.2331 (F) 770.487.3360 hoshizakiamerica.com 1A8122-010