

DOUBLE OVEN ELECTRIC RANGE



Model(s): **VUFSEE365D...**

USERS OPERATING INSTRUCTIONS

IMPORTANT - PLEASE READ AND FOLLOW

- Before beginning, please read these instructions completely and carefully.
- Do not remove permanently affixed labels, warnings, or plates from the product. This may void the warranty.
- Please observe all local and national codes and ordinances.
- Please ensure that this product is properly grounded.
- **The installer should leave these instructions with the consumer who should retain for local inspector's use and for future reference.**
- IN CANADA: The electrical plug should always be accessible.

Electrical installation must be in accordance with the National Electrical Code, ANSI/NFPA70 - latest edition and/or local codes.

IN CANADA: Electrical installation must be in accordance with the current CSA C22.1 Canadian Electrical Codes Part 1 and/or local codes.

Some models are supplied with a protective film on steel and aluminum parts. This film must be removed before installing/using the appliance.

THIS RANGE IS FOR RESIDENTIAL USE ONLY

TABLE OF CONTENTS

| CONTENTS | Page Number |
|---|--------------------|
| Important Safety Precautions & Recommendations | 3 - 4 |
| Features | 5 - 6 |
| How to use the vitroceramic hob | 7 - 8 |
| How to use the multifunction electric ovens | 9 - 14 |
| How to use the electronic programmer (left oven only) | 15 - 17 |
| Cleaning and maintenance | 28 - 23 |

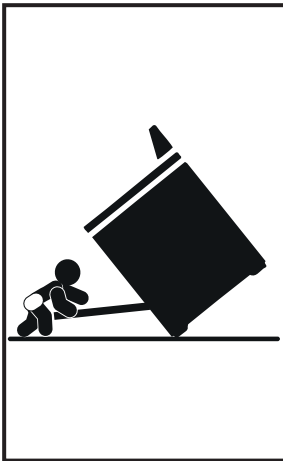

! WARNING
Tip-Over Hazard

A child or adult can tip the range and be killed. Check installation of anti-tip device per installation instructions.
Check engagement of anti-tip device if range is moved per installation.
Failure to follow these instructions can result in death or serious burns to children and adults.

See installation instructions for details.

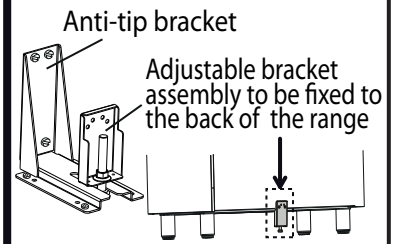

Dear Customer,

Thank you for having purchased and given your preference to our product.

The safety precautions and recommendations reported below are for your own safety and that of others. They will also provide a means by which to make full use of the features offered by your appliance.

Please preserve this booklet carefully. It may be useful in future, either to yourself or to others in the event that doubts should arise relating to its operation.

This appliance must be used only for the task it has explicitly been designed for, that is for cooking foodstuffs. Any other form of usage is to be considered as inappropriate and therefore dangerous.

The manufacturer declines all responsibility in the event of damage caused by improper, incorrect or illogical use of the appliance.



WARNING: This product can expose you to chemicals including formaldehyde, which is known to the State of California to cause cancer, and lead, which is known to the State of California to cause birth defects or other reproductive harm. For more information go to [www. P65Warnings.ca.gov](http://www.P65Warnings.ca.gov).

This appliance is designed and manufactured solely for the cooking of domestic (household) food and is not suitable for any non domestic application and therefore should not be used in a commercial environment.

The appliance warranty will be void if the appliance is used within a non domestic environment i.e. a semi commercial, commercial or communal environment.

USER INSTRUCTIONS

GENERAL INFORMATION

-  **WARNING!!**
This appliance shall not be used for space heating. This information is based on safety considerations.
- All openings in the wall behind the appliance and in the floor under the appliance shall be sealed.
- Keep appliance area clear and free from combustible materials, gasoline, and other flammable vapors.
- Do not obstruct the flow of ventilation air.
- Disconnect the electrical supply to the appliance before servicing.
- When removing appliance for cleaning and/or service;
 - Disconnect AC power supply.
 - Carefully remove the range by pulling outward.
CAUTION: Range is heavy; use care in handling.
- Electrical Requirement**
Electrical installation should comply with national and local codes.
- The misuse of oven door (e.g. stepping, sitting, or leaning on them) can result in potential hazards and/or injuries.
- When installing or removing the range for service, a rolling lift jack should be used. Do not push against any of the edges of the range in an attempt to slide it into or out of the installation. Pushing or pulling a range (rather than using a lift jack) also increases the possibility of bending the leg spindles or the internal coupling connectors.

IMPORTANT PRECAUTIONS AND RECOMMENDATIONS

After having unpacked the appliance, check to ensure that it is not damaged.

In case of doubt, do not use it and consult your supplier or a professionally qualified technician.

Packing elements (i.e. plastic bags, polystyrene foam, nails, packing straps, etc.) should not be left around within easy reach of children, as these may cause serious injuries. The packaging material is recyclable and is marked with the recycling symbol .

- Do not attempt to modify the technical characteristics of the appliance as this may become dangerous to use.
- Do not carry out cleaning or maintenance operations on the appliance without having previously disconnected it from the electric power supply.
- After use, ensure that the knobs are in **Off** position.
- Do not allow children or other incapable people to use the appliance without supervision.
- During and after use of the range, certain parts will become very hot. Do not touch hot parts.
- Keep children away from the range when it is in use.
- Some models are supplied with a protective film on steel and aluminum parts. This film must be removed before installing/using the appliance.
- Fire risk!** Do not store flammable material in the oven and in the warming drawer.
- Make sure that electrical cables connecting other appliances in the proximity of the range cannot come into contact with the hob or become entrapped in the oven door.
- Do not line the oven walls with aluminum foil. Do not place shelves, broiler pan, pans or other cooking utensils on the base of the oven chamber.
- The manufacturer declines all liability for injury to persons or damage to property caused by incorrect or improper use of the appliance.
- To avoid any possible hazard, the appliance must be installed by qualified personnel only. Any repairs by unqualified persons may result in electric shock or short circuit. In order to avoid possible injuries to your body or to the appliance, do not attempt any repairs by yourself. Such work should be carried out by qualified service personnel only.
- Danger of burns!** The oven and cooking accessories may become very hot during operation. Make sure children are kept out of reach and warn them accordingly. To avoid burns use kitchen clothes and gloves when handling hot parts or utensils.
- Stand away from the range when opening oven door. Hot air or steam which escapes can cause burns to hands, face, and/or eyes.
- Never clean the range, oven and the warming drawer with a high-pressure steam cleaning device, as it may provoke a short circuit.
- This appliance is intended for use in your household. Never use the appliance for any other purpose!
- If you should decide not to use this appliance any longer (or decide to substitute an older model), before disposing of it, it is recommended that it be made inoperative in an appropriate manner in accordance to health and environmental protection regulations, ensuring in particular that all potentially hazardous parts be made harmless, especially in relation to children who could play with old appliances. Remove the door and the warming drawer before disposal to prevent entrapment.
- IMPORTANT NOTE:** The oven shelves (for some products one shelf only is provided) have not been designed to place the food directly on the shelf itself. When cooking, always place the food in special containers or use specific materials suitable for the food contact.

WARNING!!

ELECTRICAL GROUNDING INSTRUCTIONS

The range must be electrically grounded in accordance with local codes or, in the absence of local codes, with the National Electrical Code, ANSI/NFPA No. 70-latest edition, in Canada Canadian Electrical Code. Installation should be made by a licensed electrician.

FOR PERSONAL SAFETY, THIS APPLIANCE MUST BE PROPERLY GROUNDED.

If an external electrical source is utilized, the installation must be electrically grounded in accordance with local codes or, in the absence of local codes, with the national Electrical Code, ANSI/NFPA 70.

REPLACEMENT PARTS

Only authorized replacement parts may be used in performing service on the range. Replacement parts are available from factory authorized parts distributors. Contact the nearest parts distributor in your area.

IMPORTANT PRECAUTIONS AND RECOMMENDATIONS FOR USE OF ELECTRICAL APPLIANCES

Use of any electrical appliance implies the necessity to follow a series of fundamental rules.

In particular:

- Never touch the appliance with wet hands or feet.
- Do not operate the appliance barefooted.
- Do not allow children or disabled people to use the appliance without your supervision.

The manufacturer cannot be held responsible for any damages caused by improper, incorrect or unreasonable use of the appliance.

1. FEATURES

Fig. 1.1

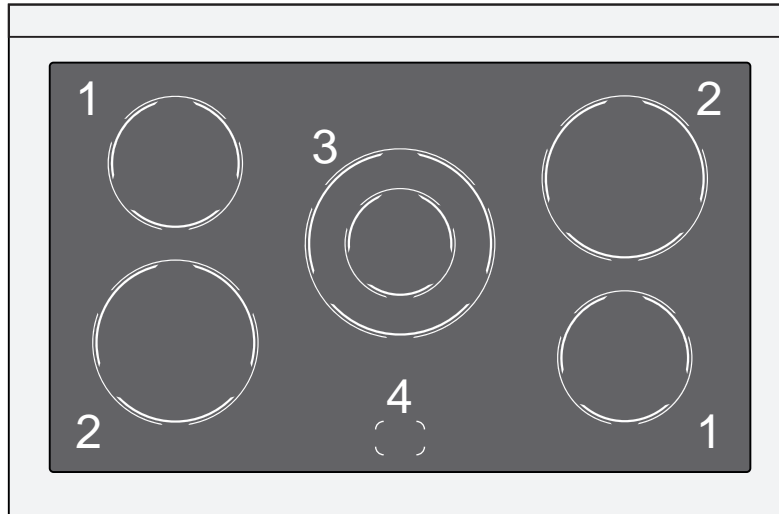

VITROCERAMIC COOKING HOB

1. Cooking zone Ø 145 mm (5" 23/32) - 1200 W
2. Cooking zone Ø 180 mm (7" 3/32) - 1700 W
3. Double cooking zone Ø 205/110 (8" 1/16 / 4" 21/64) - 2100/700 W
4. Cooking zones residual heat indicators

Attention: Disconnect the appliance from the mains if the ceramic hob is cracked and call the After Sales Service.

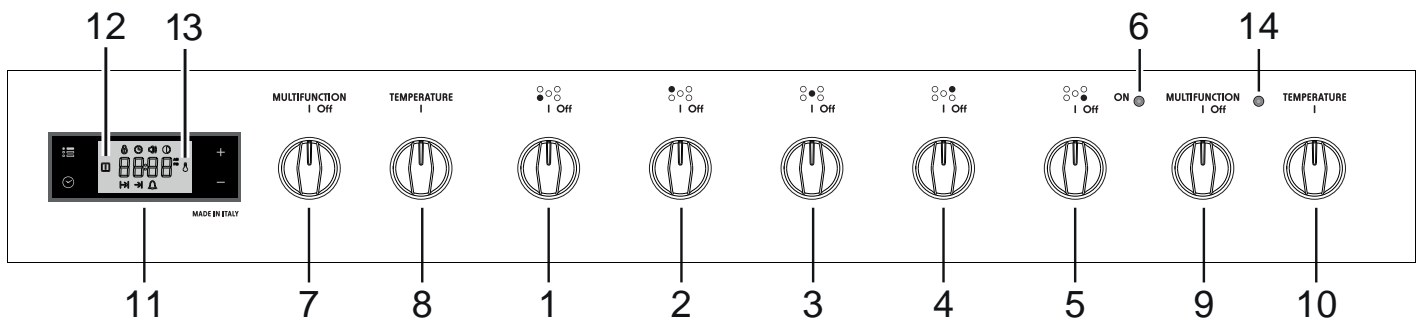

CONTROLS DESCRIPTION

1. Front left cooking zone (2) control knob
2. Rear left cooking zone (1) control knob
3. Central double cooking zone (3) control knob
4. Rear right cooking zone (2) control knob
5. Front right cooking zone (1) control knob
6. Cooking zones power indicator light
7. Left main oven switch knob
8. Left main oven thermostat knob
9. Right oven switch knob
10. Right oven thermostat knob
11. Electronic clock/programmer "Touch-control" (left main oven only)
12. Power on indicator
13. Oven thermostat indicator
14. Oven temperature indicator light

Please note: This appliance incorporates a safety cooling fan which you will hear operating whenever the oven or grill or induction hob are in use. This fan may continue to run for several minutes after the appliance has been switched off. This fan is to reduce the external temperature of the appliance and cool the internal components.

2. HOW TO USE THE VITROCERAMIC HOB

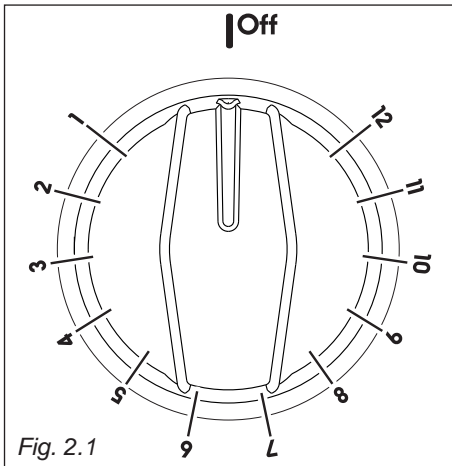

Fig. 2.1

VITROCERAMIC HOB

The ceramic surface of the hob allows a fast transmission of heat in the vertical direction, from the heating elements underneath the ceramic glass to the pans set on it. The heat does not spread in a horizontal direction, so that the glass stays "cool" at only a few centimeters from the cooking plate. The 5 cooking zones are shown by painted disks on the ceramic surface.

IMPORTANT NOTE:

The heating elements incorporate a thermolimiter that switches the element ON/OFF during all settings to protect the ceramic glass from overheating. The use of incorrect pans and/or wrong pan positioning will cause the temperature limiter to operate more frequently, resulting in a reduction of cooking performance.



Fig. 2.2a

SINGLE COOKING ZONES

Incorporating the heating element (fig. 2.2a or 2.2b) you can control and light up by selecting from the 12 positions on the control knob (fig. 2.1).

The heat intensity can be regulated continuously from **Off** to "12" (max).

VERY IMPORTANT: TO SWITCH ON, ALWAYS LIGHTLY PRESS THE CONTROL KNOB THEN TURN IT.

Check that the hob is clean and then switch on by press and turning the control knob.



Fig. 2.2b

DOUBLE COOKING ZONE

Incorporating 2 heating elements you can control and light up together or separately by turning left or right the 6 positions control knob (fig. 2.3).

The heat intensity can be regulated continuously from "1" to "6" (max).

VERY IMPORTANT: TO SWITCH ON, ALWAYS LIGHTLY PRESS THE CONTROL KNOB THEN TURN IT.

SWITCH ON THE SMALL CENTRAL ZONE (fig. 2.4)

Press and turn in counterclockwise direction the control knob from "1" to "6" (max).

SWITCH ON THE ALL ZONE (fig. 2.5)

Press and turn in clockwise direction the control knob from "1" to "6" (max).

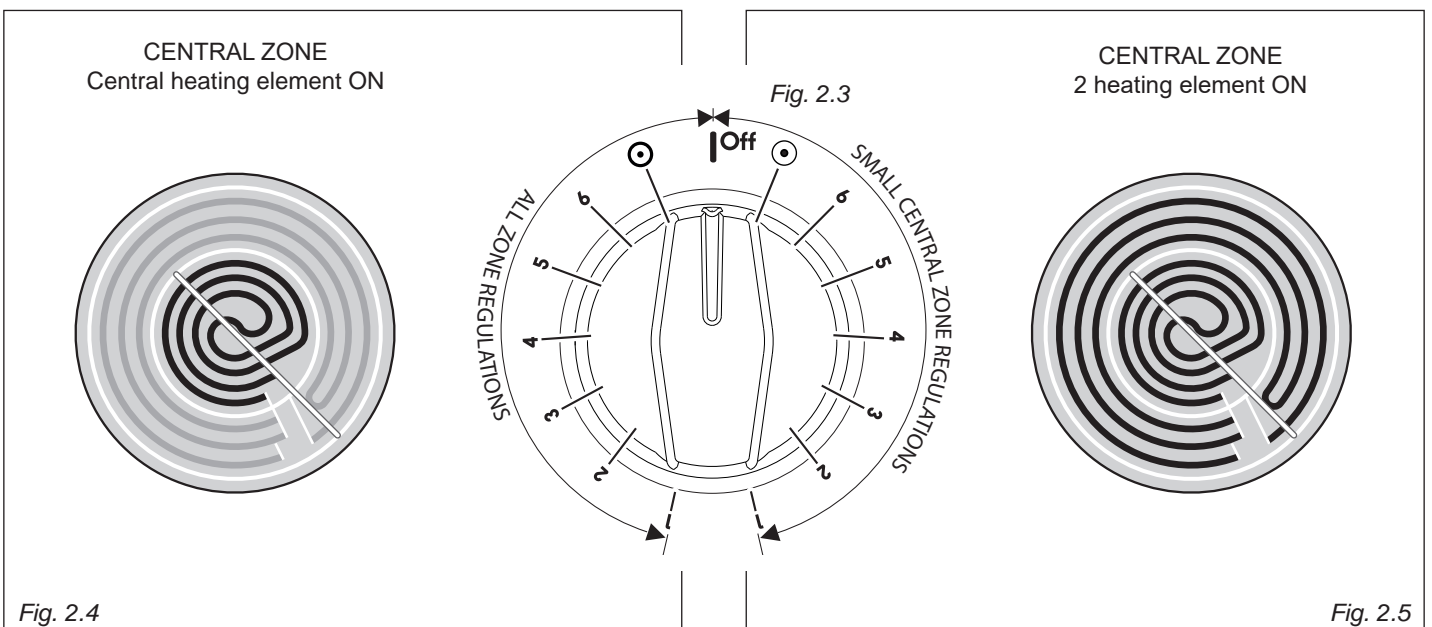

COOKING ZONES POWER INDICATOR LIGHT (fig. 2.6)

When the ceramic hob is working, the “ON” pilot light in the control panel will be on (fig. 2.6a).

COOKING ZONES RESIDUAL HEAT INDICATORS

IMPORTANT

When the temperature of a cooking zone is above 140 °F (60 °C), the relevant “HOT SURFACE” warning light in the vitroceramic hob (fig. 2.6b) will come on to indicate that the zone is hot.

This light will stay on even after the cooking zone has been switched off to indicate that the zone is still hot.

The residual heat persists for some time after the cooking zone has been switched off. **During this time avoid touching the hob and take particular care if there are children nearby.**

The light will go out automatically when the cooking zone temperature drops below 140 °F (60 °C).

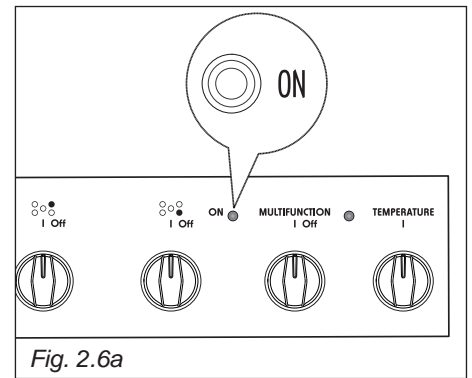

HINTS FOR SAFE USE OF THE VITROCERAMIC HOB

- Before switching on, check which knob controls the required cooking zone. You are advised to place the saucepan on the hob before switching on and to take it off after switching off.
- To switch on, always lightly press the control knob then turn it.
- Use saucepans with an even flat bottom (be careful of cast iron saucepans). Uneven bottoms can scratch the pyroceram surface. Check that the bottom is clean and dry.
- The diameter of the pan should match that of the cooking zone (or be slightly bigger) to make the most of the energy.
- Pots with aluminum bottoms may leave silver streaks or spots on the hob.
- Do not leave wet or damp lids on the hob.
- Do not use the top if the surface is broken or damaged.
- **If you note a crack in the cooktop, switch the appliance off immediately and call the After-Sales Service.**
- Do not bend over the cooking zones when they are on.
- Do not leave aluminum foil, greaseproof paper etc. or plastic on the hob when it is hot.
- Remember that the cooking zones stay hot for quite a long time (approx. 30 min.) after they have been switched off.
- Scrupulously follow the cleaning instructions.
- Do not drop heavy or sharp objects on the glass ceramic cooktop.
- Never cook the food directly on the glass ceramic cooktop, but in special pans or containers.

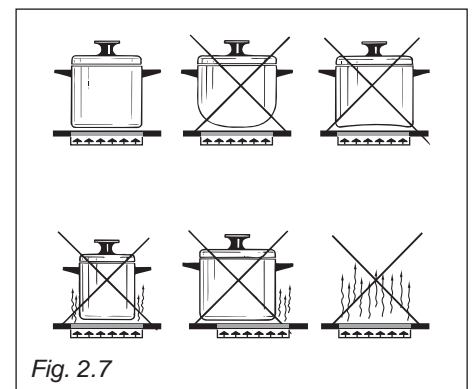
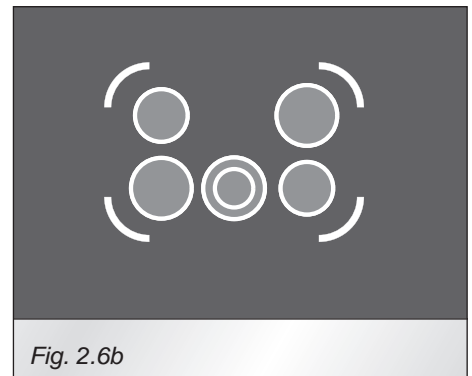

Make sure that the handles of cookware do not stick out over the edge of the range, to avoid them being knocked over by accident. This also makes it more difficult for children to reach the cooking vessels.

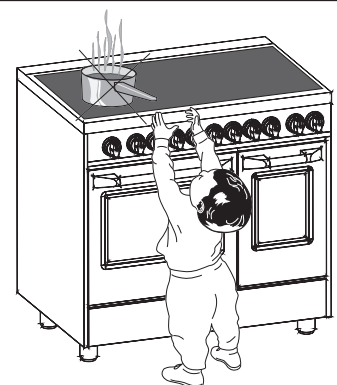

3. HOW TO USE THE MULTIFUNCTION ELECTRIC OVENS

GENERAL FEATURES (LEFT OVEN and RIGHT SMALL OVEN)

As its name indicates, this is an oven that presents particular features from an operational point of view.

In fact, it is possible to insert 7 different programs to satisfy every cooking need. The 7 positions, thermostatically controlled, are obtained by 4 heating elements which are:

- Lower heating element
- Upper heating element
- Broil heating element
- Circular heating element

ATTENTION: the range becomes very hot during operation.

ATTENTION: the oven door becomes very hot during operation.

KEEP CHILDREN AWAY.

WARNING:

The door is hot, use the handle.

VERY IMPORTANT







The oven shall be used always with the door closed.

USING THE OVENS FOR THE FIRST TIME (LEFT OVEN and RIGHT SMALL OVEN)

- Insert shelves and the tray.
- Switch the oven on empty (on a cooking function) at maximum power for about 2 hours to remove traces of grease and smells from the components.
There will be a distinctive smell and a small amount of smoke during the conditioning process as manufacturing residue is burnt off. This is normal, but make sure the kitchen is well ventilated during the conditioning.
- Switch off the electrical supply, let the oven cool down, then clean the interior of the oven with cloth soaked in water and detergent (neutral) then dry carefully.

OPERATING PRINCIPLES (LEFT OVEN and RIGHT SMALL OVEN)

Heating and cooking in the multifunction oven takes place as follows:

- **by normal convection** -  The heat is produced by the upper and lower heating elements.
- **by forced convection** -  The heat produced by the circular element is distributed throughout the oven by the fan.
- **by semi-forced convection** -  The heat produced by the upper and lower heating elements is distributed throughout the oven by the fan.
- **by radiation** -  The heat is radiated by the infra red broil element.
- **by radiation and fan** -  The radiated heat from the infra red broil element is distributed throughout the oven by the fan.
- **by double radiation** -  The heat is radiated by the infra red broil element and the upper heating element.
- **by ventilation** -  The food is defrosted by using the fan only function without heat.

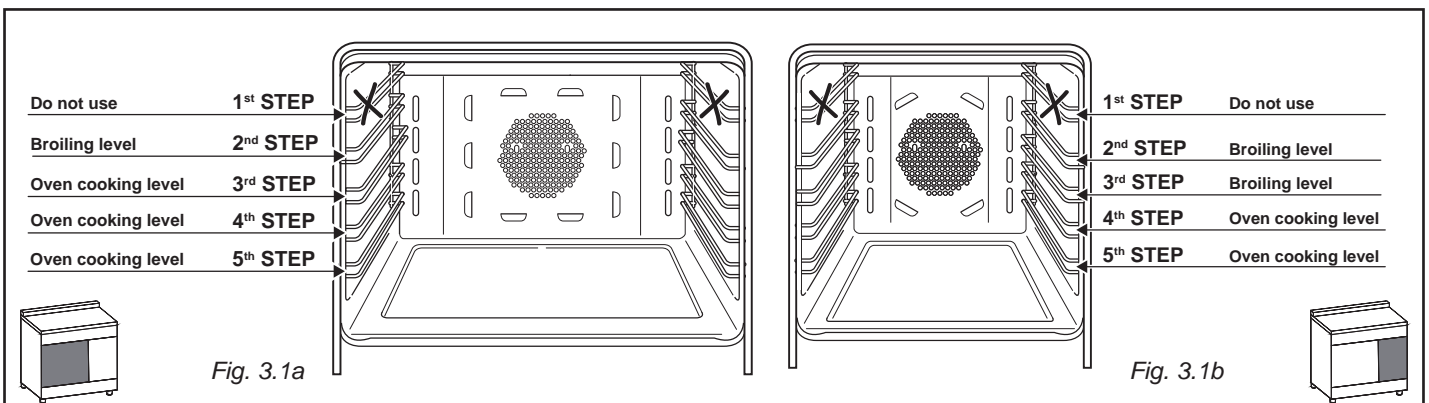

TEMPERATURE

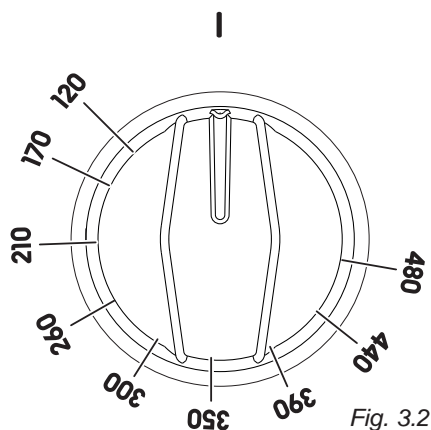

Fig. 3.2

THERMOSTAT KNOB (LEFT OVEN and RIGHT SMALL OVEN) (fig. 3.2)

To turn on the heating elements of the oven, set the switch knob on the desired program and the thermostat knob onto the desired temperature.

To set the temperature, it is necessary to make the chosen number, printed on the control panel, to match with the knob indicator (or to make the chosen number, printed on the knob, to match with the control panel indicator).

The elements will turn ON or OFF automatically according to the energy need which is determined by the thermostat.

The oven temperature indicator will cycle on and off during cooking.

MULTIFUNCTION

I Off

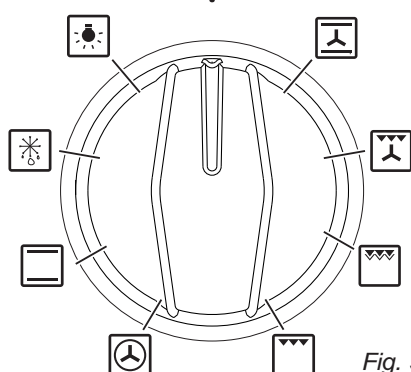

Fig. 3.3

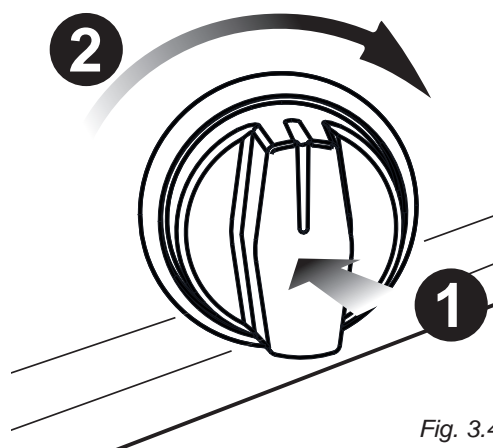

Fig. 3.4

FUNCTION SELECTOR KNOB (LEFT OVEN and RIGHT SMALL OVEN)

VERY IMPORTANT: ALWAYS LIGHTLY PRESS THE CONTROL KNOB WHEN TURNING THE FUNCTION KNOB FROM THE OFF POSITION (fig. 3.4).

Rotate the knob clockwise to set the oven to one of the following functions:



OVEN LIGHT (this is not a cooking function)

Turning the knob to this position, only the oven lamp lights up. The lamps is always on in all the cooking functions.



DEFROSTING FROZEN FOODS (this is not a cooking function)

Only the fan and the oven lamp switch on. To be used with the thermostat knob on **Off** because the other positions have no effect.

Defrosting takes place by fan, without heating.

Recommended for:

To rapidly defrost frozen foods; 2.2 lbs (1 kg) requires about one hour.

The defrosting times vary according to the quantity and type of foods to be defrosted.



TRADITIONAL CONVECTION COOKING

The upper and lower heating elements switch on.

The heat is diffused by natural convection and the temperature must be set between 120 °F (50 °C) and 480 °F (250 °C) via the thermostat knob.

Recommended for:

For foods which require the same cooking temperature both internally and externally, i.e. roasts, spare ribs, etc.



VENTILATED COOKING

The circular element and fan come on.

The heat is dispersed by forced convection and the temperature can be regulated to between 120 °F (50 °C) and 480 °F (250 °C) via the thermostat knob. The oven does not require preheating.

Recommended for:

Food which has to be well-cooked outside and soft or rosy inside, for example lasagne, lamb, roast beef, whole fish etc.



BROILING

The infrared broil heating element switches on.

The heat is diffused by radiation. The temperature can be set between 120 °F (50 °C) and 480 °F (250 °C) via the thermostat knob.

For correct use see the “BROILING & DOUBLE BROIL” section.

Recommended for:

Intense broiling action for cooking with the broiler; browning, crisping, toasting, etc.



COOKING WITH DOUBLE BROIL

The infrared broil and the top heating elements switch on.

The heat is diffused by radiation. The temperature can be set between 120 °F (50 °C) and 480 °F (250 °C) via the thermostat knob.

For correct use see the “BROILING & DOUBLE BROIL” section.

Recommended for:

Intense broiling action for cooking with the broiler; browning, crisping, toasting, etc.



VENTILATED BROILING

The infrared broil heating element and the fan switch on. The heat is mainly diffused by radiation and the fan distributes it in the whole oven.

The temperature can be set between 120 °F (50 °C) and 480 °F (250 °C) via the thermostat knob.

For correct use see the “VENTILATED BROILING” section.

Recommended for:

For grill cooking when a fast outside browning is necessary to keep the juices in, i.e. veal steak, steak, hamburger, etc.



CONVECTION COOKING WITH VENTILATION

The upper and lower heating elements and the fan turn on.

The heat is dispersed by forced convection and the temperature can be regulated to between 120 °F (50 °C) and 480 °F (250 °C) via the thermostat knob.



Recommended for:

For foods of large volume and quantity which require the same internal and external degree of cooking; for i.e.: rolled roasts, turkey, legs, cakes, etc.

COOKING ADVICE (LEFT OVEN AND RIGHT SMALL OVEN)

STERILIZATION

Sterilization of foods to be conserved, in full and hermetically sealed jars, is done in the following way:

- Turn the switch to position  or .
- Set the thermostat knob to position 350 °F (175 °C) and preheat the oven.
- Fill the grill pan with hot water.
- Set the jars into the grill pan making sure they do not touch each other and the door and set the thermostat knob to position 260 °F (130 °C).

When sterilization has begun, that is, when the contents of the jars start to bubble, turn off the oven and let cool.



REGENERATION

Turn the switch to position  or  and set the temperature to 300 °F (150 °C).



Bread becomes fragrant again if wet with a few drops of water and put into the oven for about 10 minutes.

ROASTING

To obtain classical roasting, it is necessary to remember:

- the pre-set temperature should be maintained.
- that the cooking time depends on the quantity and the type of foods.

COOKING DIFFERENT DISHES AT THE SAME TIME

The MULTIFUNCTION oven at positions  or  of the function selector can cook various different foods at the same time. Fish, cakes and meat can be cooked together without the smells and flavors mixing.

The only precautions required are the following:

- The cooking temperatures must be as close as possible with a maximum difference of 70-80 °F (20-25 °C) between the different foods.
- Different dishes must be placed in the oven at different times according to the cooking time required for each one. This type of cooking obviously provides a considerable saving on time and energy.

VENTILATED BROILING

Ventilated broiling may be done by selecting  with the function selector knob; the hot air completely envelops the food that is to be cooked.

Introduce the food to be cooked, positioning the grill pan on the broiling level.

Close the door and let the oven operate until broiling is done.

Adding a few dabs of butter before the end of the cooking time gives the golden "au gratin" effect.

Broiling with the oven door closed.

Important: Use always suitable protective gloves when inserting/removing the broiling pan from the oven (see next page).

AIR FRY ENAMELLED TRAY - LEFT OVEN (some models only)

The special Air Fry enamelled tray has a perforated surface so as to facilitate the entry of air, giving the dishes a tasty crispy effect without adding condiments.

Recommended for:

French fries (frozen potatoes classic or rustics), chicken wings, potato croquettes and other frozen or pre-cooked foods.

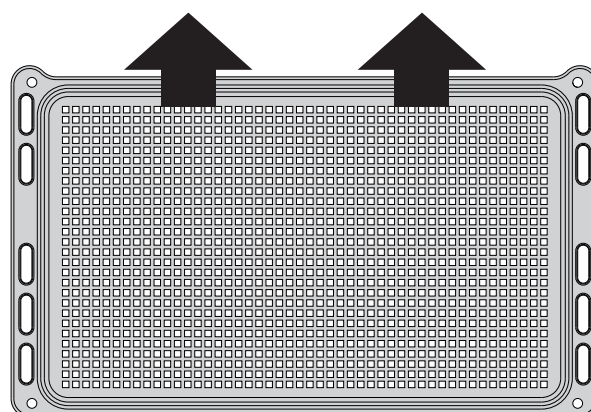

LEFT OVEN

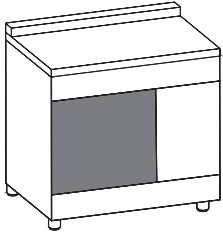

- | | |
|--------------------|----------------------|
| Do not use | 1 st STEP |
| Broiling level | 2 nd STEP |
| Oven cooking level | 3 rd STEP |
| Oven cooking level | 4 th STEP |
| Oven cooking level | 5 th STEP |

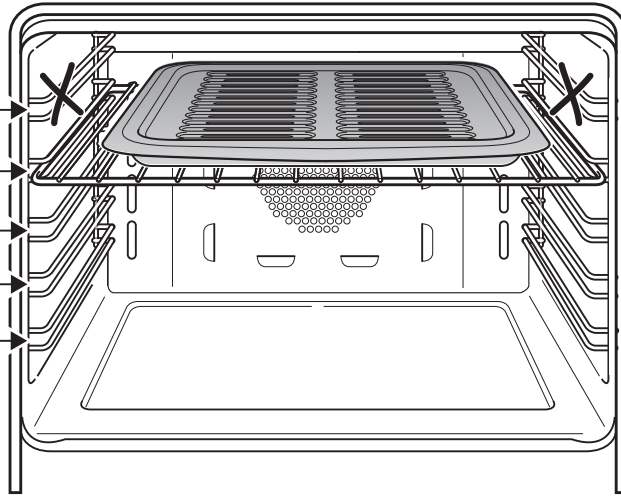

Fig. 3.5

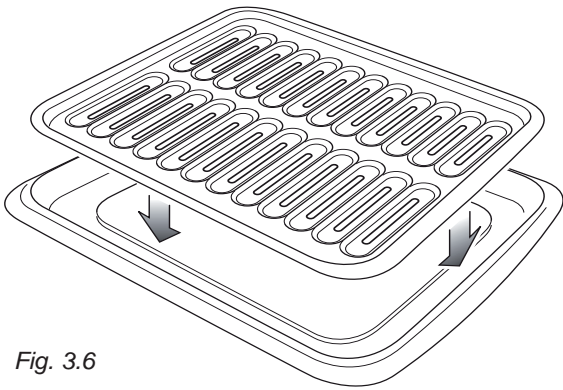

Fig. 3.6

BROILING & DOUBLE BROIL (LEFT OVEN)

Very important: the broil or double broil must always be used with the oven door closed.

- Position the shelf on the second level from the top (fig. 3.5).
- Turn on the broil or double broil, as explained in the preceding paragraphs, and let the oven preheat for about 5 minutes with the door closed.
- Place the food to be cooked above the broiling pan.
- Introduce the broiling pan in the oven (figs. 3.6 - 3.8). The broiling pan should be placed above the shelf and it should be centered with the broil element (fig. 3.5).

Important: Use always suitable protective gloves when inserting/removing the broiling pan, shelves, pans or other cooking utensils from the oven.

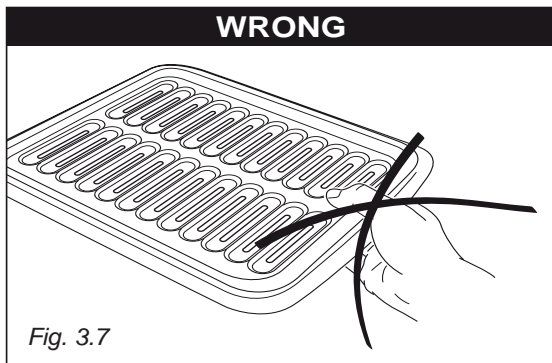

Fig. 3.7

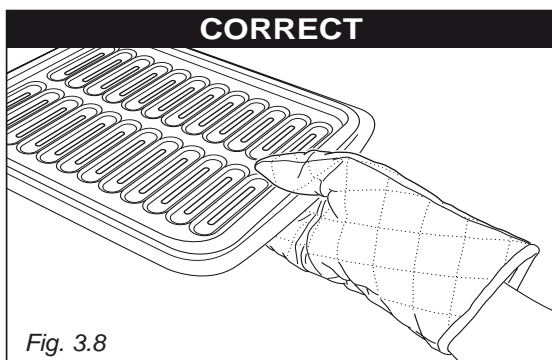
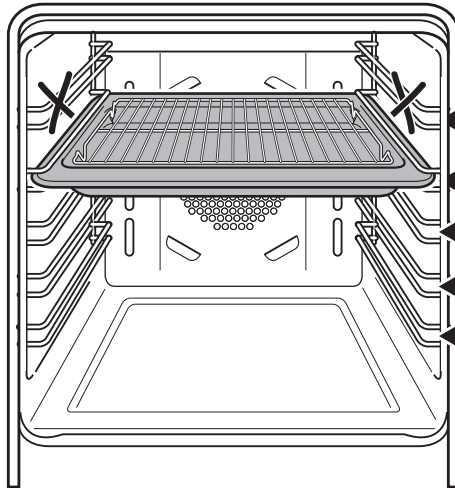
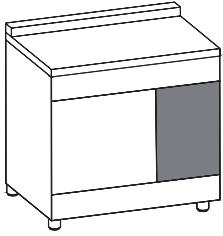

Fig. 3.8

RIGHT SMALL OVEN



| | |
|----------------------|--------------------|
| 1 st STEP | Do not use |
| 2 nd STEP | Broiling level |
| 3 rd STEP | Broiling level |
| 4 th STEP | Oven cooking level |
| 5 th STEP | Oven cooking level |

Fig. 3.9

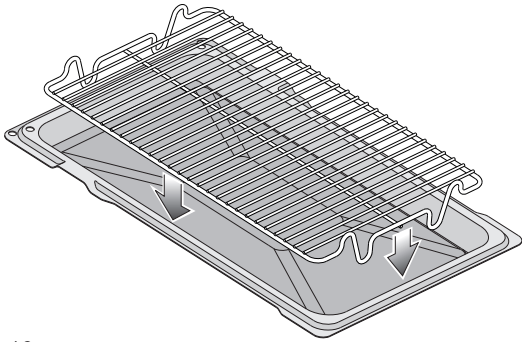

Fig. 3.10

BROILING & DOUBLE BROIL (RIGHT SMALL OVEN)

Very important: the broil or double broil must always be used with the oven door closed.

- Turn on the broil or double broil, as explained in the preceding paragraphs, and let the oven preheat for about 5 minutes with the door closed.
- Place the food to be cooked above the grill-pan grid.
- Introduce the grill-pan (tray + grid) (figs. 3.10 - 3.12) in the oven and insert it on the second or third level from the top (fig. 3.9). The grill-pan (tray + grid) must be fitted so that the safety catch (fig. 3.12), which stops it sliding out, faces the inside of the oven.

Important: Use always suitable protective gloves when inserting/removing the grill-pan, shelves, pans or other cooking utensils from the oven.

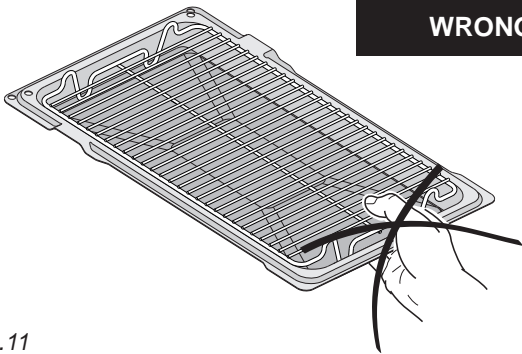

Fig. 3.11

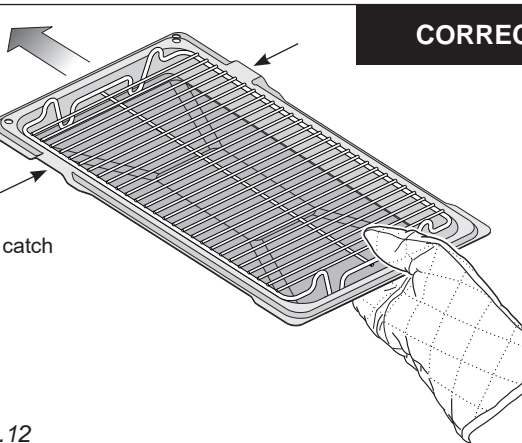

Fig. 3.12

4. HOW TO USE THE ELECTRONIC PROGRAMMER (LEFT OVEN ONLY)

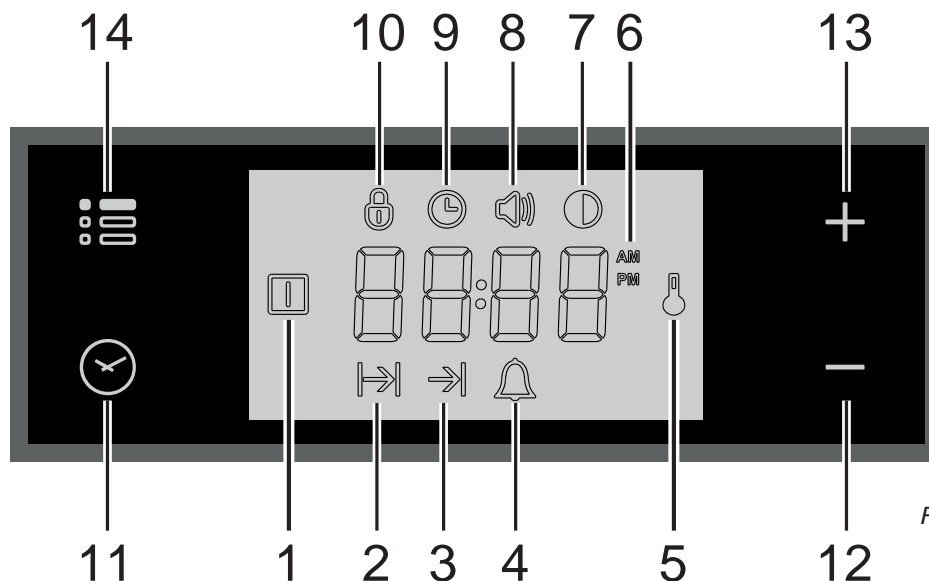

Fig. 4.1

Description of display symbols:

1. Oven on (left oven only)
2. Cooking time (left oven only)
3. End of cooking time (left oven only)
4. Timer
5. Oven temperature (left oven only)
6. AM/PM time format
7. Screen brightness
8. Acoustic signal volume
9. Time of day setting
10. Programmer 'touch control' panel key lock

Description of the 'touch control' panel symbols:

11. Program selection
12. Digit backward setting for all functions
13. Digit forward setting for all functions
14. Menu selection

IMPORTANT NOTE: When using the timer and during a semi-automatic or automatic cooking, the countdown of the function with less time remaining prevails on the display.

ATTENTION - MOST IMPORTANT:

ELECTRONIC PROGRAMMER DISPLAY CLEANING

Strictly follow the information indicated in the chapter "CLEANING AND MAINTENANCE".

"TOUCH-CONTROL" KEYS

The "touch-control" keys shall be operated by the fingers (just by touching the key).

When using touch controls it is best to use the ball of your finger rather than the tip.

Program and menu selection: after starting the procedure, the selection is automatically deactivated after approx. 5 seconds from the last touch on the display.

SETTING THE CLOCK

When connecting for the first time, or after a power failure, the word "OFF" flashes on the display and the "🕒" symbol is lit. Adjust the time touching the "+" or "-" key.

Important: The oven does not operate, in manual cooking, without first having set the clock.

To change the time with the appliance already installed, touch the "☰" key for more than 2 seconds, then touch it again until the "🕒" symbol flashes. Then adjust the time, within 5 seconds, using the "+" or "-".

Important: It is not possible to adjust the clock if a cooking program is in progress.

During a semi-automatic or automatic oven cooking program, once completed the programming procedure the oven lamp(s) will be lit until the end of the cooking program. This means that, in case of delayed cooking start, the oven lamp(s) will remain always lit.

In addition, if a fan assisted semi-automatic or automatic oven cooking program is set, further to the oven lamp(s) also the oven fan motor(s) [the motor(s) inside the oven cavity] may be operating (together with the cooling fan motor, this is possible if the oven or cooktop has been used previously and the range is still hot/warm) before the start of the cooking program.

USING THE TIMER

You can use the timer at any time, even when the oven is not in use.

ATTENTION - MOST IMPORTANT: This is only an alarm that DOES NOT switch off the oven or broil.

REMEMBER TO TURN OFF THE OVEN/BROIL MANUALLY.

The timer can be set for a maximum time of 23 hours and 59 minutes.

1. To set the timer, with the appliance already connected, touch the "⏸" key (several times) until the "🔔" symbol flashes on the display. Set the time (increase in minutes) within 5 seconds using the "+" or "-" key. At the end of the adjustment the display shows the countdown.
2. At the end of the count, the timer starts beeping and the "🔔" symbol flashes on the display. Touch any key to turn off the acoustic signal that would otherwise stop after 7 minutes.
3. Turn the oven off manually (switch and thermostat knobs in the off position) if you do not wish to continue with manual cooking.

To reset the timer in operation at any time:

- 1A. Only timer function active (no semi-automatic or automatic cooking in progress): touch the "⏸" key for 3 seconds.
- 1B. With semi-automatic or automatic cooking in progress: touch the "⏸" key several times until the "🔔" symbol flashes on the display. Then touch the "-" key within 5 seconds until "00:00" appears on the display.
2. The time of day is shown on the display.

SEMI-AUTOMATIC COOKING (LEFT OVEN ONLY)

This is used to automatically switch off the oven after the desired cooking time has elapsed.

Check the clock shows the correct time.

The semi-automatic cooking program can be set for a maximum period of 10 hours.

1. Select the function and temperature (function and temperature knobs). The oven will come on.
2. Touch the "⏸" key until the "🔔" symbol flashes on the display. Set the cooking time (increase in minutes - consider the preheating time, if necessary) within 5 seconds using the "+" or "-" key. At the end of the adjustment the display shows the countdown.
3. At the end of the count the oven turns off, the timer starts beeping, the "🔔" symbol flashes and the word "End" appears on the display.
4. Turn the temperature and function knobs to the off position.
5. Touch the "⏸" key to deactivate the acoustic signal (which otherwise will stop after 7 minutes) and to return the programmer to manual mode (the time is shown on the display). If instead the acoustic signal is deactivated with one of the other keys, after deactivation also touch the "⏸" key to return the programmer to manual mode (the time is shown on the display).

To cancel the semi-automatic cooking program at any time:

- 1A. Only semi-automatic cooking function active (no timer in use): touch the "⏸" key for 3 seconds, the "🔔" symbol and the word "End" are shown on the display.
- 1B. With active timer: touch the "⏸" key several times until the "🔔" symbol flashes. Then touch the "-" key within 5 seconds until "00:00" appears on the display, replaced after a few seconds by the "🔔" symbol and the word "End".
2. Touch the "⏸" key again to return the programmer to manual mode (the time of day is shown on the display). If cooking is finished turn the temperature and function knobs to the off position, otherwise continue cooking and then remember to turn the oven off manually.

AUTOMATIC COOKING (LEFT OVEN ONLY)

Use automatic cooking to automatically turn the oven on, cook, and then turn the oven off.

Check the clock shows the correct time.

1. Select the function and temperature (function and temperature knobs). The oven will come on.
2. Decide the cooking time considering the preheating time, if necessary, and set it as described above in the "SEMI-AUTOMATIC COOKING" chapter.
3. Touch the "⏸" key several times until the "🔔" symbol appears on the display. Then set the time at which you want the oven to turn off, touching the "+" or "-" key.
4. If the cooking is not started immediately, the display shows the current time of day and the "🔔" and "🔔" symbols. The oven turns off but now it is set for automatic operation.
 - To check the cooking time, touch the "⏸" key once, the "🔔" symbol flashes.
 - To check the turn-off time, touch the key "⏸" several times until the "🔔" symbol flashes.

To cancel the automatic cooking program at any time, proceed as described in the "SEMI-AUTOMATIC COOKING" chapter.

Turn the temperature and function knobs to the off position, otherwise continue cooking and then remember to turn the oven off manually.

ATTENTION - VERY IMPORTANT (AUTOMATIC OR SEMI-AUTOMATIC COOKING):

If a very short power interruption occurs, the oven keeps the programming.

If the interruption is instead longer than a few tens of seconds, the automatic cooking is cancelled. In this case, turn the temperature and function knobs to the off position and restart programming if necessary.

USER PREFERENCES SETTINGS

PROGRAMMER 'TOUCH-CONTROL' PANEL KEY LOCK

This function is used to prevent the accidental touch of the programmer selection keys and to avoid unintentionally activating or modifying its functions.

The key lock can be activated at any time, with a cooking in progress or with the oven off.

To lock:

- Touch the "☰" key for more than 2 seconds until the "🔒" indicator light starts flashing. Then touch the "+" key to activate the key lock, the word "On", appears on the display, wait a few seconds until the operation is completed. When this function is active, the "🔒" indicator light is on.

To unlock:

- Touch the "☰" key for more than 2 seconds until the "🔒" indicator light starts flashing. Then touch the "-" key to deactivate the key lock, the word "OFF" appears on the display, wait a few seconds until the operation is completed. When this function is not active, the "🔒" indicator light is off.

ACOUSTIC SIGNAL TONE SETTING

It is possible to select three sound tones.

- Touch the "☰" key for more than 2 seconds, then touch the same key several times until the "🔊" symbol flashes.
- Touch the "+" or "-" key; the display shows the tone set ("b-01", "b-02" or "b-03").
- The last tone displayed remains active.

SCREEN BRIGHTNESS SETTING

It is possible to select three brightness levels.

- Touch the "☰" key for more than 2 seconds, then touch the same key several times until the "🕒" symbol flashes.
- Touch the "+" or "-" key; the display shows the brightness set ("d-01", "d-02" or "d-03").
- The last brightness displayed remains active.

TIME FORMAT

It is possible to choose the 24 hour or 12 hour clock format.

- To activate the 12 hour format, touch the "+" key for more than 5 seconds until the "AM" or "PM" symbol is activated.
- To activate the 24 hour format, touch the "+" key for more than 5 seconds until the "AM" or "PM" symbol is deactivated.

5. CLEANING AND MAINTENANCE

GENERAL RECOMANDATION

- **Important: Before any operation of cleaning and maintenance disconnect the appliance from the electrical supply.**
- It is advisable to clean when the appliance is cold and especially for cleaning the enamelled parts.
- Avoid leaving alkaline or acidic substances (lemon juice, vinegar, etc.) on the surfaces.
- Avoid using cleaning products with a chlorine or acidic base.
- The oven must always be cleaned after every use, using suitable products and keeping in mind that its operation for 30 minutes on the highest temperature eliminates most grime reducing it to ashes.

WARNING

When correctly installed, your product meets all safety requirements laid down for this type of product category. However special care should be taken around the rear or the underneath of the appliance as these areas are not designed or intended to be touched and may contain sharp or rough edges, that may cause injury.

ENAMELLED PARTS

- All the enamelled parts must be cleaned with a sponge and soapy water or other non-abrasive products.
- Dry preferably with a microfiber or soft cloth.
- Acidic substances like lemon juice, tomato sauce, vinegar etc. can damage the enamel if left too long.

PAINTED PARTS AND SILK-SCREEN PRINTED SURFACES

- Clean using an appropriate product. Always dry thoroughly.

IMPORTANT: these parts must be cleaned very carefully to avoid scratching and abrasion. You are advised to use a soft cloth and neutral soap.

STAINLESS STEEL ELEMENTS

- Stainless steel parts must be rinsed with water and dried with a soft and clean cloth.
- For difficult dirt, use a specific non-abrasive product available commercially or a little hot vinegar.
- **Note: regular use could cause discoloring around the burners, because of the high flame temperature.**

INSIDE OF OVEN

The oven should always be cleaned after use when it has cooled down.

The cavity should be cleaned using a mild detergent solution and warm water.

Suitable proprietary chemical cleaners may be used after first consulting with the manufacturers recommendations and testing a small sample of the oven cavity.

Abrasive cleaning agents or scouring pads/cloths should not be used on the cavity surface.

NOTE: The manufacturers of this appliance will accept no responsibility for damage caused by chemical or abrasive cleaning.

Let the oven cool down and pay special attention not to touch the hot heating elements inside the oven cavity.

ELECTRONIC PROGRAMMER DISPLAY CLEANING

Clean the programmer display using a soft cloth, warm water and neutral soap, or a soft cloth with a liquid detergent (non-abrasive).

When cleaning, be careful to move the cloth in one direction only.

Then wipe the display with a damp cloth and dry it with a soft cloth.

IMPORTANT: DO NOT use chlorine-based or acid-based cleaning products, abrasive products or non-neutral detergents as they may cause irreparable damage to the surface. **DO NOT** spray cleaning liquids directly on the programmer display.

WARNING VERY IMPORTANT

Before any operation of maintenance disconnect the appliance from the electrical mains supply.

Do not use steam jet cleaners because the humidity could infiltrate into the appliance making it dangerous.

Do not use harsh abrasive cleaners or sharp metal scrapers to clean the oven door glass since they can scratch the surface, which may result in shattering of the glass.

WARNING!!



Do not store flammable material in the oven or in the storage drawer.

VITROCERAMIC SURFACE

Before cleaning the cooktop, make sure that it is switched off.

Remove any encrustation using a special scraper which can be bought (fig. 5.1).

Remove dust using a damp cloth.

Detergents can be used as long as they are not abrasive or corrosive.

All residues of detergent must be eliminated with a damp cloth.

Keep all objects that could be melted by the heat away from the top: plastic objects, aluminum foil, sugar or sugary products.

If an object melts on the top, remove immediately (while the top is still hot) using a special scraper to avoid permanent damage to the pyroceram surface. Avoid using knives and pointed objects as they could damage the surface of the top.

Also avoid using abrasive sponges or wire wool which can permanently scratch the pyroceram surface.

ATTENTION: MOST IMPORTANT!

If cleaning the glass ceramic hob using a special scraper tool take extra care to avoid damaging to the seal at the edges of the glass ceramic surface.

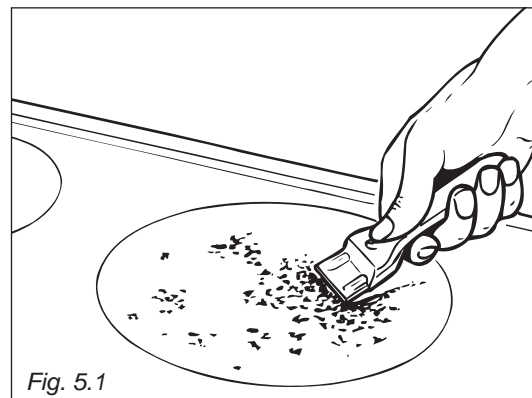

OVEN FITTING OUT

- Slide the rear prongs of the side rack into the holes "A" at the rear of the oven (fig. 5.2a).
- Slide the front prong of the side rack into the hole at the front of the oven (fig. 5.2b).
- Slide in, on the guides, the shelf and the tray (fig. 5.2c).
The shelf must be fitted so that the safety notch, which stops it sliding out, faces the inside of the oven; the guard rail shall be at the back.
- To dismantle, operate in reverse order.

IMPORTANT NOTE: The oven shelves have not been designed to place the food directly on the shelf itself. When cooking, always place the food in special containers or use specific materials suitable for the food contact.

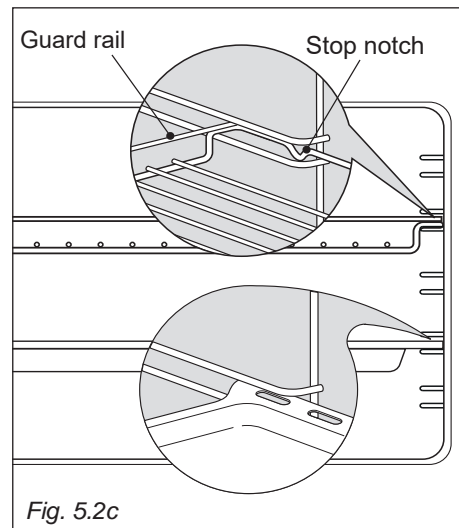
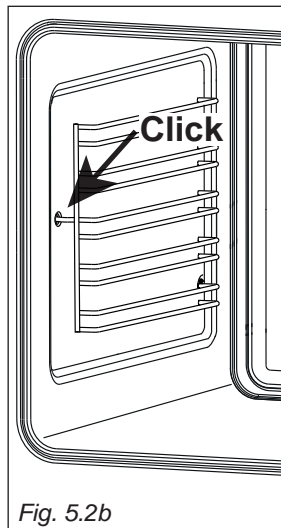
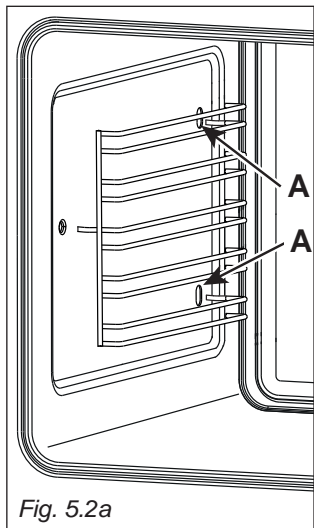

TELESCOPIC SLIDING SHELF SUPPORTS (SUPPLIED WITH SOME MODELS ONLY)

The telescopic sliding shelf supports make it safer and easier to insert and remove the oven shelves and trays. They stop when they are pulled out to the maximum position.

Important! When fitting the sliding shelf supports, make sure that you fit:

- The slides to the top wire of a rack. They do not fit on the lower wire.
- The slides so that they run out towards the oven door.
- Both sides of each pair of shelf slides.
- Both sides on the same level.

To fix the sliding shelf supports onto the side racks:

- Fit the side racks onto the oven walls (figs. 5.2a, 5.2b).
- Fit the sliding shelf supports onto the top wire of a rack and press (fig. 5.3). You will hear a click as the safety locks clip over the wire.

To remove the telescopic sliding shelf supports:

- Remove the side racks (figs. 5.2a, 5.2b).
- Lay down the sliding shelf support and side racks, with the telescopic sliding shelf support underneath.
- Find the safety locks. These are the tabs that clip over the wire of the side rack (arrow "1" in fig. 5.4).
- Pull the safety locks away from the wire to release the wire (arrow "2" in fig. 5.4).

Cleaning the sliding shelf supports:

- Wipe the supports with a damp cloth and a mild detergent only.
- Do not wash them in the dishwasher, immerse them in soapy water, or use oven cleaner on them.

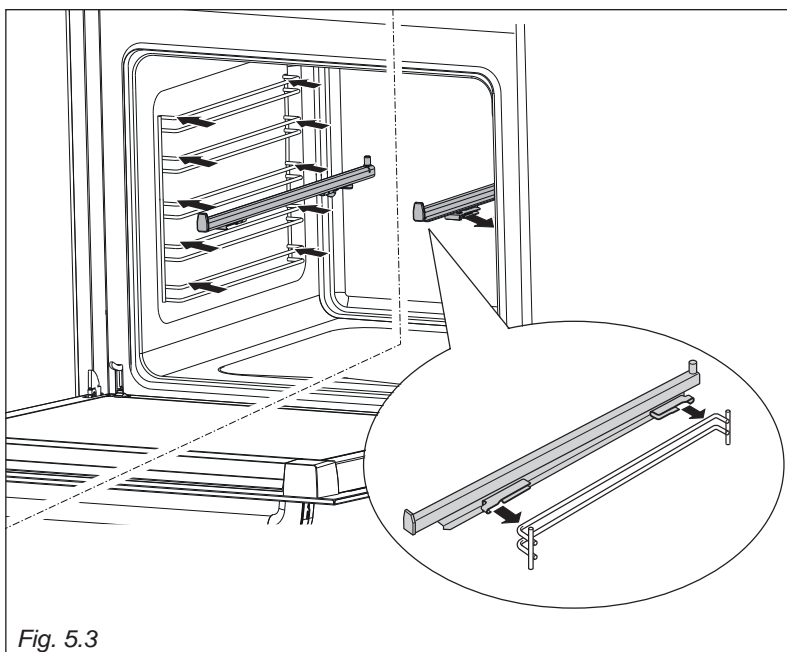

Fig. 5.3

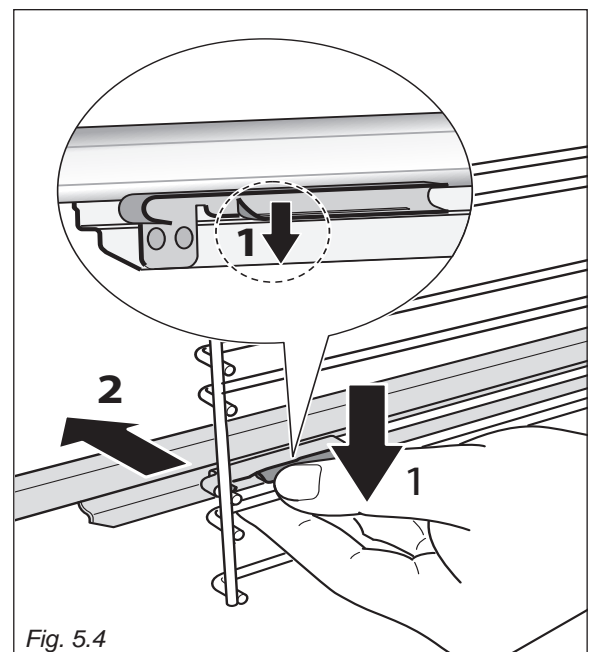

Fig. 5.4

REPLACING THE OVEN LIGHT

WARNING: Ensure the appliance is switched off before replacing the lamp to avoid the possibility of electric shock.

- Let the oven cavity and the heating elements to cool down.
- Switch off the electrical supply.
- Remove the protective cover (figs. 5.5).
- Replace the halogen lamp with a new one suitable for high temperatures having the following specifications: 120 V ac and same power (check watt power as stamped in the bulb itself) of the replaced lamp.
IMPORTANT WARNING: Never replace the lamp with bare hands; contamination from your fingers can cause premature failure. Always use a clean cloth or gloves.
- Refit the protective cover.

NOTE: Oven bulb replacement is not covered by your guarantee.

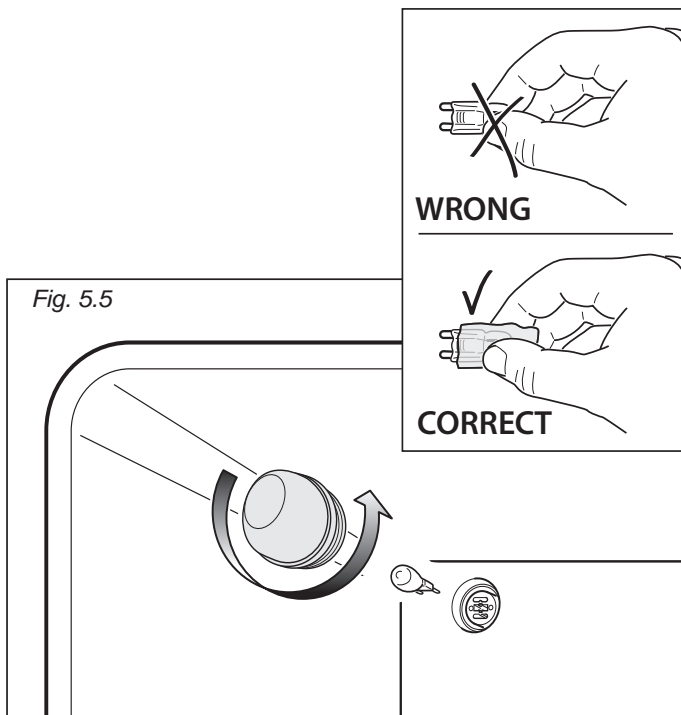

WARNING!

Do not store flammable material in the ovens or in the storage compartment.

STORAGE COMPARTMENT

The storage compartment is accessible through the bottom pivoting panel (fig. 5.6).

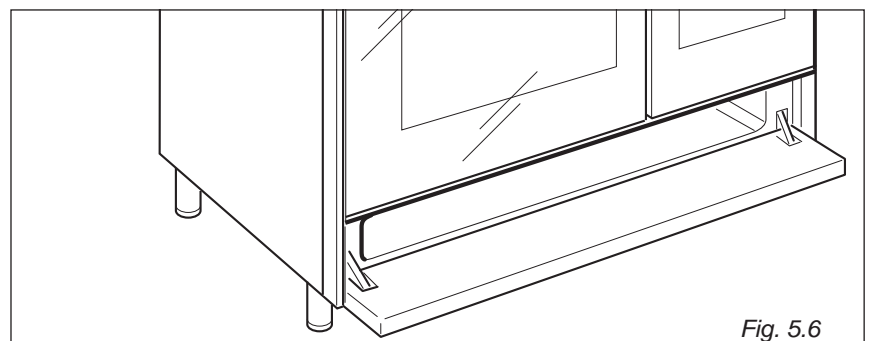
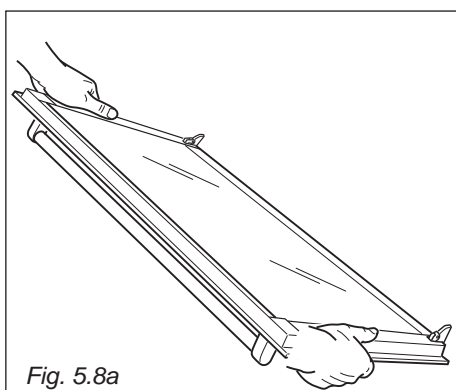
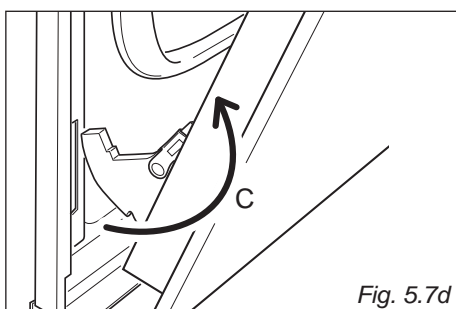
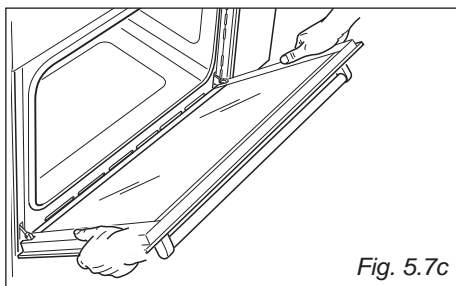
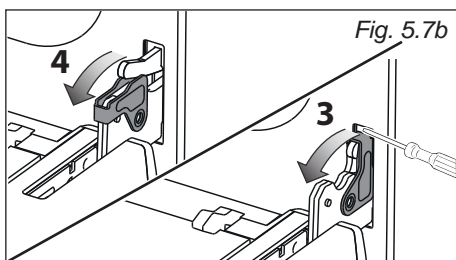
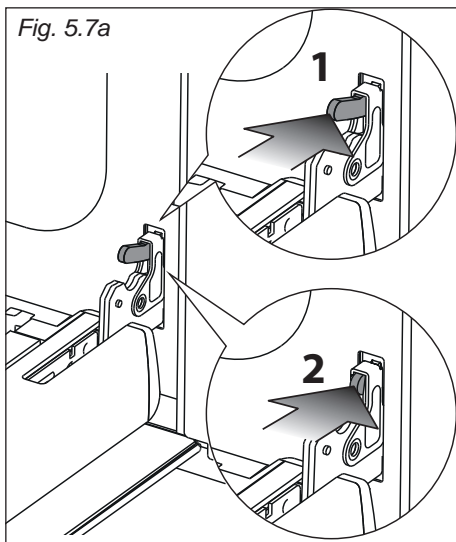

Fig. 5.6



REMOVING THE OVEN DOOR(S)

The oven door(s) can easily be removed as follows:

- Open the door to the full extent (fig. 5.7a) and check to see which side the damper hinge is fitted for the soft close feature as shown in fig. 5.7a. This may be fitted on left or right of the door depending on exact model.
- Push the Damper Pin (arrow 1 in fig. 5.7a) slowly, applying pressure until it moves in towards the oven and becomes flush with the hinge lever (arrow 2 in fig. 5.7a). The Damper Pin does not react immediately and is very slow to move as it necessary to overcome the inertia of the soft close mechanism. If the Damper Pin is difficult to move, it may be necessary to use a suitable tool to allow extra pressure to be exerted, for example the back of a teaspoon. Please pay special care whilst pressing to avoid slipping and injury.
- Keeping the Damper Pin flush with the hinge lever (arrow 2 in fig. 5.7a), rotate the hinge lever forward by using a small flat screw driver (arrow 3 in fig. 5.7b) ensuring that you do not damage the enamel or oven.
- Rotate the hinge lever completely (arrow 4 in fig. 5.7b). Repeat this step for the other hinge.
- Hold the oven door by two hands and close it until the hinge levers hook to the oven door and the door no longer closes easily (fig. 5.7c).
- Withdraw the hinge hooks from their location following arrow "C" (fig. 5.7d).
- Rest the door on a soft surface.

Important!

Always keep a safe distance from the door hinges, paying special attention to the position of your hands.

If the door hinges are not correctly hooked, they could unhook and close suddenly and unexpectedly with risk of injury.

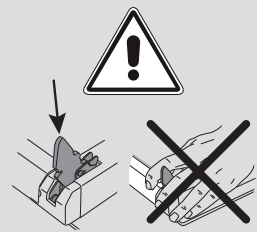

REFIT THE OVEN DOOR(S)

- Hold the door firmly (fig. 5.8a).
- Insert the hinge tongues into the slots, making sure that the groove drops into place as shown in the fig. 5.8b.
- Open the door to its full extent.
- Fully close the levers "A" on the left and right hinges, as shown in the fig. 5.8c.
IMPORTANT NOTE: For the hinge fitted with the Damper Pin, push the hinge lever towards the Damper Pin and keep depressed. The Damper Pin will move into the oven chassis slowly, allowing the hinge lever to fully rotate.
- Close the door and check that it is properly in place.

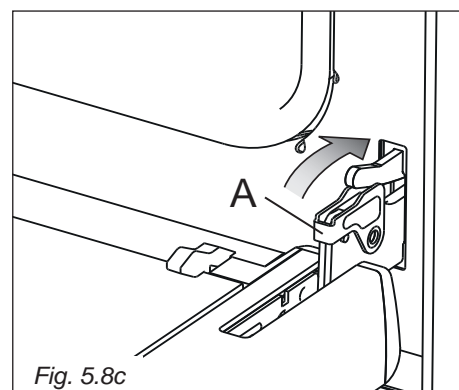
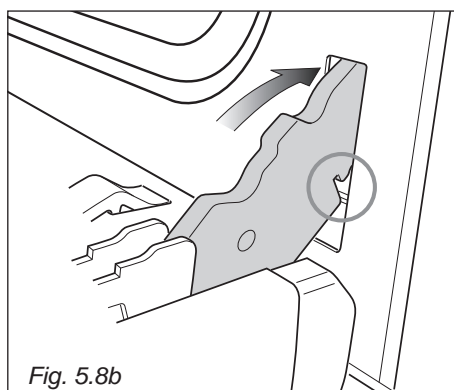

DO'S AND DO NOT'S

- Do always use the oven(s) with the door closed.
- Do always broil with the door closed.
- Do read the user instructions carefully before using the range for first time.
- Do allow the oven(s) to heat for about two hours, before using for the first time, in order to expel any smell from the new oven insulation, without the introduction of food.
- Do clean your oven(s) regularly.
- Do remove spills as soon as they occur.
- Do always use oven gloves when removing food shelves and trays from the oven(s).
- Do not allow children near the range when in use.
- Do not allow fat or oils to build up in the oven base, or oven accessories.
- Do not place cooking utensils or plates directly onto the oven base.
- Do not place hot enamel parts in water. Leave them to cool first.
- Do not allow vinegar, coffee, milk, saltwater, lemon or tomato juice to remain in contact with enamel parts (i.e. inside the oven).
- Do not use abrasive cleaners or powders that will scratch the surface of the stainless steel and the enamel.
- Do not attempt to repair the internal workings of your range.
- Do remove the protective film before the first use.
- Fire risk! Do not store flammable material in the oven(s) and in the storage compartment (bottom drawer).
- Do not use the oven(s) with the oven door open.
- Do not use the oven(s) to warm or heat a room.

FOR YOUR SAFETY

Under no circumstances should any external covers be removed for servicing or maintenance except by suitably qualified personnel

The manufacturer cannot be held responsible for possible inaccuracies due to printing or transcription errors in the present booklet.

The manufacturer reserves the right to make all modifications to its products deemed necessary for manufacture or commercial reasons at any moment and without prior notice, without jeopardising the essential functional and safety characteristics of the appliances.